

NO. 31

\$2.00

DECEMBER 1980

MICRO™

THE 6502 JOURNAL



Multiplying on the 6502

Atari Bits

Creating an Applesoft BASIC Subroutine Library

Cassette I/O for SYM BASIC

A C1P User's Notebook

STUFFIT: A Time-Saving Utility Program for PET BASIC Files

PERMANENT RELIEF

Of today's and tomorrow's Word Processing problems



Apple PIE

Apple PIE (Programma International Editor) and FORMAT (text formatter) offer full strength solutions to today's word processing problems. These versatile, powerful programs provide document preparation and word processing capabilities previously found only on much larger computer systems.

PIE is a general purpose, full screen editor that uses control keys and function buttons to provide a full range of editing capabilities such as search and replace, delete, copy, insert, move. Changes may be made directly anywhere on the screen and are shown as they are performed.

FORMAT uses simple instructions embedded in the input text to describe the desired appearance of the final document. It handles centering, underlining, indenting, page numbering,

+

Formatter

margins, headers, footers, even form letters, and includes a proofing capability.

These high-quality, cost-effective programs come with comprehensive documentation and run on a 32K Apple II. They are available through your local computer store or direct from Programma International, Inc. at the introductory price of \$79.95*.

VIDEX VERSION T.M.
DOUBLE VISION T.M.
SUPR TERM VERSION T.M.
STANDARD VERSION

*December 1, \$129.95.

PROGRAMMA

3400 Wilshire Boulevard
Los Angeles, California 90010

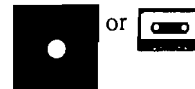

Simple enough for the beginner. Versatile enough for the professional.



Southeastern Software 'NEWSLETTER' for APPLE II Owners
NOW IN THE THIRD YEAR OF PUBLICATION
10 Issues per year for \$10.00
Back Issues available at \$1.00 each
EXAMPLE:
Send \$10.00 and receive next 10 Issues
Send \$30.00 and receive 30 Issues beginning with #2

DATA CAPTURE 3.0 - \$29.95

Is DATA CAPTURE 3.0 just another Smart Terminal program? NO! It is a GENIUS Terminal program for use with the Micromodem II[®]. It will 'capture' ANYTHING that appears on the screen of your CRT. ANY program or data. If you are using the Source you can even 'capture' CHAT. There is no need to create files in your file space on the other system to transfer data to your Apple. If you can list it you can capture it.

- * You can then SAVE the data to disk, dump it to your printer or even do simple editing with DATA CAPTURE 3.0.
- * You can use DATA CAPTURE 3.0 to compose text off line for later transmission to another computer. Think of the timeshare charges this will save you!
- * Use DATA CAPTURE 3.0 with the Dan Paymar Lower Case Adapter and you can enter UPPER or lower case from the keyboard for transmission to another system. You can also capture UPPER/lower case data from another system.
- * A program is also included to convert your programs to text files for transmission using DATA CAPTURE 3.0.
- * DATA CAPTURE 3.0 will save you money if you are using any timesharing system.

Requires DISK II[®], Applesoft II[®]

Add \$64.95 to order the Dan Paymar Lower Case Adapter

BAD BUY DISKETTE - \$9.99

Of course it's a bad buy. If you have issues #2 thru #11 of the NEWSLETTER you can type these programs in yourself. Includes a couple of bonus programs.

Requires DISK II[®], Applesoft II[®]

We ship within 3 working days of receipt of order and welcome your personal check. We also accept Visa and Master Charge.

LCMOD for PASCAL - \$30.00

Finally! DIRECT entry of UPPER/lower case into the Pascal Editor. Why pay hundreds of dollars for a terminal just to set lower case entry with Pascal? If you have the Paymar Lower Case Adapter you can use this program.

- * Left and right curly brackets for comment delimiters.
- * An underline for VARs, program names and file names.
- * The ESCape key does the shifting and Control Q is used for ESCape. Have you ever typed in a page or two of text and lost it by hitting ESC accidentally? This won't happen with LCMOD.

Requires Language System and Paymar LCA

Add \$64.95 to order the Dan Paymar Lower Case Adapter.

MAG FILES - \$18.00

Finding it difficult to keep track of all those magazine articles you are reading? This program will help you do it. MAG FILES is Menu driven with separate modules for creating, editing, displaying and searching for your data. If you are using one drive a program is provided for transferring data to another diskette for backup. A sample data base of over 60 articles is included. The screen formatting and user orientation are what you have come to expect of Southeastern Software.

Requires DISK II[®], Applesoft II[®].

MAILER - \$15.00

Don't let the low cost fool you. This is a single drive version of the program we use to maintain the NEWSLETTER subscriber list. Can be easily converted to 2.3 or 4 drives. Binary search and linear searches for finding any name in file. Sort on names and zip codes. Selective print by zip code or key. The separate modules are menu driven and will run on 32K system. There are 13 separate modules on the diskette for maintaining a mailing list. Sample data file included.

Requires DISK II[®], Applesoft II[®].

- * Apple, Apple II Plus, Disk II and APPLESOFT II are trademarks of Apple Computer Company.
- * Micromodem II is a trademark of D.C. Hayes Associates, Inc.

Malibu microcomputing

presents: 3 GREAT PROGRAMS FOR YOUR APPLE*!

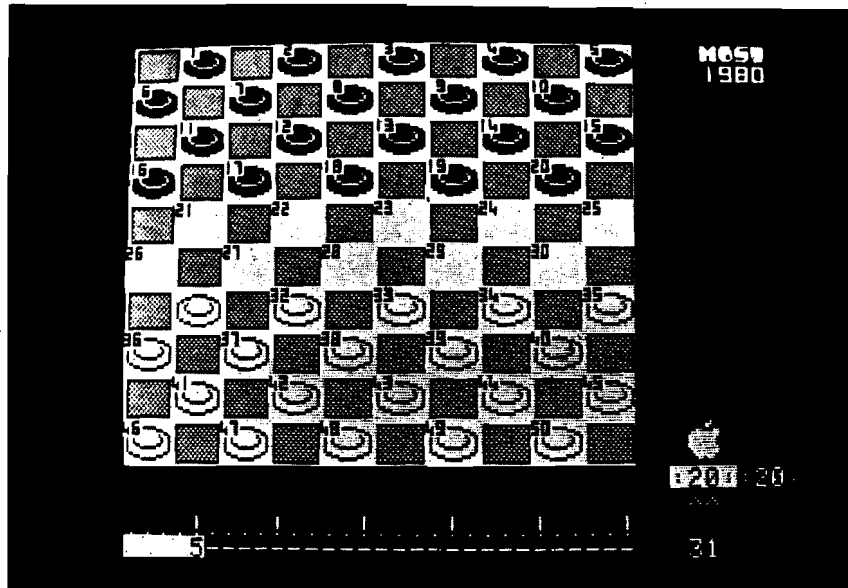

ULTRACHECKERS™

The most advanced checkers program ever available. Combines superb graphics / sound effects and exceptional ease of operation with advanced artificial intelligence techniques. Checkers are played according to International rules with nine levels of play. Program features "self-demonstration," "advice" and "problem" modes. "Self-demonstration" allows the APPLE to play itself at a speed you control. "Advice" permits you to ask the APPLE to recommend your next move. "Problem" allows special board set-ups for "what-if" questions. Excellent for learning or improving your game! Moves are easily made using cursor control. Complete playing rules and program instructions included.

32K, Machine Language for the Apple II or II Plus
\$29.95 / Disk

APPLEPRINT ## USING™

Give your Apple a flexible print capability like the big machines! Format your output by simply using the PRINT ###.###; variable, statement. ##APPLEPRINT## USING is independent from and does not interfere with the normal Applesoft PRINT statement. Indispensable for financial and business programming. Will pay for itself in no time at all as you save hours of tedious effort formatting reports, lists, tables, etc. Complete instructions and example programs included.

32K, Machine Language for the Apple II Plus
\$19.95 / Disk

"LEARNING-FUN" DUO™

Especially designed for young children. Combines learning with fun! Program 1: "TELL-TIME" Interacts with the child in color, and HI-RES GRAPHICS to facilitate learning to tell time. Program 2: "SUPER RACE CAR" is the popular head-on collision type arcade game with simplified two finger control for children. Hours of learning and fun.

32K, Applesoft / Machine Language
\$14.95 / Disk

Available at your local computer store

MALIBU MICROCOMPUTING

23910A De Ville Way, Malibu, California 90265 • (213) 456-1137

DEALER INQUIRIES INVITED All orders shipped same day.

Software may be ordered directly by calling or writing. Orders may be C.O.D. / Check / Master Charge / Visa. Add \$1 shipping. California residents add 6% sales tax.

Software available in Europe at: SIVEA, 31 Bd. des Batignolles, PARIS 75008.

*Apple is a trademark of the Apple Computer Co.

MICRO™

THE 6502 JOURNAL

CONTENTS

- 7** GRAPHING RATIONAL FUNCTIONS
General-purpose graphing on a high-resolution screen
By Ron Carlson
- 11** A C1P USER'S NOTEBOOK
Graphics, ACIA, and Tape Control Secrets
By Robert L. Elm
- 15** DRAWING A LINE ON PET's 80 x 50 GRID
Use of PET's quarter-box graphic characters
By Harvey S. Davis
- 21** A RANDOM-CHARACTER MORSE CODE TEACHER FOR THE AIM 65
A novel approach to learning Morse Code
By Eugene V. Weiner, Marvin L. DeJong, and Russell V. Lenth
- 25** AN APPLE FLAVORED LIFESAVER
Flexible storage for a popular computer simulation
By Gregory L. Tibbetts
- 37** CREATING AN APPLESOFT BASIC SUBROUTINE LIBRARY
Use of the EXEC command to link Applesoft programs
By N.R. McBurney
- 45** STUFFIT: A TIME SAVING UTILITY PROGRAM FOR PET BASIC FILES
Create a large file system on only one cassette
By Roger C. Crites
- 57** ATARI BITS
Wonders of the ATARI
By Len Lindsay
- 61** RELOCATING OSI ROM BASIC PROGRAMS
OSI BASIC's internal points revealed!
By William L. Taylor
- 65** CASSETTE I/O FOR SYM BASIC
Expand the capabilities of SYM BASIC
By Nicholas J. Vrtis
- 71** MULTIPLYING ON THE 6502
Five methods for multiplying on a computer
By Brooke W. Boering

DEPARTMENTS

- 5** Editorial — *Form and Substance* — Robert M. Tripp
- 33** PET Vet — New Products from Commodore — Loren Wright
- 43** Microscope — PBASIC - DS Version Two™ - Gordon Thompson
- 51** New Publications — Two New 6502-Based Books
- 53** Microprocessors in Medicine: The 6502 — Jerry W. Froelich
- 59** Letterbox
- 75** MICRO Club Circuit
- 78** Microbes
- 79** The MICRO Software Catalog: XXVII
- 87** Up From the Basements — Jeffery Beamsley
- 89** 6502 Bibliography: Part XXVII — William R. Dial
- 95** Advertisers' Index

STAFF

Editor/Publisher
ROBERT M. TRIPP

Associate Publisher
RICHARD RETTIG

Associate Editor
MARY ANN CURTIS

Typesetting
EMMALYN BENTLEY

Director Marketing
JAMES ANDERSON

Advertising Manager
L. CATHERINE BLAND

Circulation Manager
CAROL A. STARK

MICRO Specialists
APPLE: FORD CAVALLARI
PET: LOREN WRIGHT
OSI: PAUL GEFFEN

Comptroller
DONNA M. TRIPP

MICRO is published monthly by:
MICRO INK, Inc., Chelmsford, MA 01824
Second Class postage paid at:
Chelmsford, MA 01824
Publication Number: COTR 395770
ISSN: 0271-9002
Subscription rates: U.S. \$15.00 per year
Foreign surface mail \$18.00 per year
Central America air \$27.00 per year
So. Amer/Europe air \$33.00 per year
Other air mail \$39.00 per year

For back issues, subscriptions, change
of address or other information, write to:
MICRO
P.O. Box 6502
Chelmsford, MA 01824

Copyright © 1980 by MICRO, INK, Inc.
All Rights Reserved

LOWER CASE + PLUS

for the APPLE II
by Lazer Systems

\$59.95
RETAIL

QUALITY. That's why you bought your APPLE II or APPLE II PLUS Computer in the first place. Why compromise the quality of your computer by purchasing a "cheap" looking Lower Case Adapter? LAZER SYSTEMS announces the **Lower Case + Plus**, the first high quality lower case adapter available for the Apple II.

Compare the features of the top three lower case adapters available for the Apple II:

	Lower Case +	Paymar	Uni-Text
# of Displayable Characters	128	96	96
Inverse Upper & Lower Case	Yes	No	Yes
FONT SIZE	7 x 8	5 x 7	5 x 8
# of On Board Character Sets	2	1	1
Basic Software Provided on Disk	Yes	No	No
Pascal Software	Yes	No	Yes
Optional FONTS Available	Yes	No	???
Single Board Which Works with All Apples	Yes	No	No
Expansion Socket for use with Graphics + Plus (a RAM-Based Character Generator)	Yes	No	No
TRUE Descenders on Lower Case Characters	Optional	No	Yes
Single Board Construction (No inconvenient & unsightly Wire Jumpers)	Yes	No	No
Character Generator 2716-EPROM Compatible	Yes	No	Yes
Character Set Compatible with Character Set Created by Mountain Hardwares "Keyboard Filter"	Yes	No	No
OPTIONAL Character FONTS included on Diskette	Yes	No	???
Extensive User Documentation	Yes	No	???
Compatible with Most Major Word Processors	Yes*	No	Yes
High Quality Double Side PC Board with Silkscreen & Soldermask	Yes	No	No
On Board Graphics Character Set	Yes	No	No
Reset Key Disable	Yes	No	No
Suggested Retail Price	\$59.95	\$64.95	\$79.95

*Apple Writer requires optional character generator for proper operation.

As you can see the LAZER SYSTEMS' **Lower Case + Plus** is an order of magnitude better than the competition. YET IT COSTS LESS THAN EITHER OF THE COMPETING UNITS.

Bring your Apple out of the dark ages. Word processing and applications programs without lower case is a bad reflection on your computer. **ORDER YOUR LOWER CASE + PLUS TODAY!**

ORDER FROM: **LAZER SYSTEMS**
Box 55518
Riverside, CA 92517

We gladly accept Mastercard and Visa. Include No., Expiration Date, and Signature. Enclose a copy of this ad and take **\$5.00** off the retail price of your **Lower Case + Plus**. (Offer good till Dec. 31, 1980). Buy one for a friend as a Christmas present. Better yet, buy yourself one and give your old lower case adapter to a friend!

The following prices include 6% sales tax for California residents, \$2.00 Shipping and Handling for U.S. orders, \$15.00 Shipping & Handling for foreign orders, and \$5.00 discount. No COD's please. Please allow two weeks for personal checks to clear.
Calif.: \$60.25 (with copy of ad)
Other: \$56.95 (with copy of ad)
Outside U.S.: \$69.95 U.S. currency, certified check (with copy of ad)
Dealer inquiries invited.

P.O. Box 55518 • Riverside, Ca 92517

M2

MICRO

Editorial

Form and Substance

An Important Announcement: MICRO has not been bought by McGraw-Hill, Hayden, or anyone else. The new look is simply part of MICRO's evolution. Nor have the philosophy and purpose of MICRO changed.

Form

Since we intend to make MICRO the best journal possible, we engaged a design consultant. This issue incorporates many of his recommended changes. These include:

1. *A new MICRO logo.* Our new logo, presenting a more modern image, is intended to reflect the fact that we are one of the leaders in the microcomputer explosion.

2. *An improved cover.* Because over half our sales are through dealers, we want the cover to make a dramatic impact on the magazine rack. The "inside-the-computer-looking-out" concept has been kept, but we have improved the artwork. To help computer store customers in their browsing, we have put the issue number and date on top where they are more visible, and we have added to the bottom of the cover the titles of major articles.

3. *A new typeface.* We have changed from Helios, a very plain typeface, to a face called Trump, which we believe will be easier to read. Since the purpose

of MICRO is to provide printed information, this is perhaps our most important change.

4. *Standardized listings.* In the past, we photographed and printed most listings as received. Some did not reproduce well, for example, dot-matrix printing and the AIM light blue printouts. The various sizes and shapes of listings also made for an uneven appearance. Furthermore, every assembler had different syntax features. To overcome these problems, we now have our Technical Services staff regenerate all listings. This not only results in standardized syntax and size, it also enables the staff to review the programs in detail. Listings should therefore be more accurate and easier to read.

Substance

Does this attention to form mean that we are neglecting our primary purpose—to provide information about the 6502? Not at all! The substance of MICRO is richer than ever.

1. *Improved articles.* MICRO was founded in 1977 to provide the important information which the 6502 community needed but was not getting. The backbone of MICRO has always been articles on how to use 6502-based microcomputers more effectively. Since in this field "no one knows everything and everyone knows something," we have received and published hundreds of articles from computerists of all levels of experience and from various backgrounds. Reader-generated articles will continue to be our mainstay. We are pleased with the quality and quantity of material we are receiving. Now, with an expanded technical and editorial staff, we are in a better position to work with authors, to

improve their articles and to make MICRO read better than ever.

2. *Additional departments.* While articles provide important information, often not available elsewhere, their subject matter is somewhat random. Each author writes about what he feels is important. To fill the inevitable gaps, MICRO has a number of departments to cover the 6502 world systematically. Some departments have been with MICRO a long time. Others are new or still in the planning stage. The old standbys include the 6502 Bibliography, whose numbered entries have now reached the 800 mark (but have covered many thousands of individual items); The Software Catalog, which has presented many new products in its 27 appearances; and the Club Circuit, which continues to publicize 6502-based clubs. New departments have appeared recently and more are scheduled within the coming months.

3. *Enlarged staff.* Until recently, most members of the MICRO staff had to be able to handle many jobs: editing, circulation, advertising, typesetting, layout, sales, etc. While we put out a good product, it became obvious we needed more people and a better organization. To solve this problem, we have expanded and regrouped our staff. We now have separate groups responsible for Editorial, Production, Circulation, Advertising, Technical Services, and Art. With this expanded and newly organized team, the substance of MICRO will continue to be enhanced.

Robert M. Trapp

Editor/Publisher

About the Cover

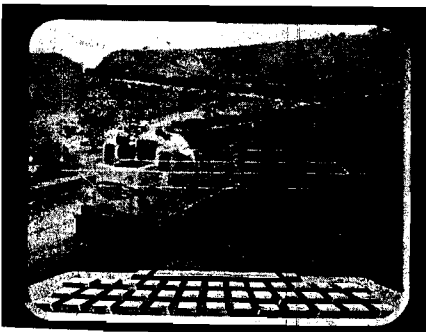

Computers have played important roles in railroading for years, starting with giant mainframes, then minicomputers, and now microcomputers.

A yardmaster at Santa Fe's modern Barstow Yard may well have used a computer display like this one to direct the make up of the train. One part of the yard is called a "hump" yard, where an engine backs a string of cars over a hump for automatic sorting. As the car on the end of the string reaches the top, its number and track assignment are automatically displayed, and it is uncoupled from the other cars in front of it. The correct switches are then thrown to allow the car to roll onto the proper track. On the way down, the acceleration of the car is measured, and the proper braking force is applied to make it arrive safely. Computers

are important at all stages of this operation.

The new GP-50 locomotive uses a feedback system, controlled by an on-board computer, to keep the wheels from slipping on the rails.

Microcomputers have already found their ways into model railroading, controlling yard switches, and even running several trains on a layout automatically.

Some rapid transit systems, such as BART (Bay Area Rapid Transit), in San Francisco, rely on computers for everything from collecting fares to actually running the trains.

Loren Wright, MICRO's PET Vet and resident railroad enthusiast, took this photo in March, 1979, near Bealville, California in the Tehachapi Mountains just south of Bakersfield.



5 GREAT GAMES!

For Apple II Plus, 48K
All Hi-res games chock full of
shape table shapes!



ANIMAL BINGO: There are 50 animals of 10 types on your gameboard (monitor). The object is to line up 5 animals horizontally or vertically for "bingos", via certain game commands. Sounds simple, but a good score requires the brains of a good chess player. How can something that seems so easy be so challenging? Find out. \$9.95 disk

JUNGLE SAFARI: A great Hi-res adventure - - - all the thrills of a real jungle safari. Ten different animals - - - shoot them before they pounce on you! \$9.95 disk

SPACE DEFENSE: Use your game paddles and buttons to manipulate your starship or fire lasers or photon torpedos, as you defend yourself against all manner of alien attackers. Beautiful sound effects (mach. lang.). \$9.95 disk

SKY WATCH: Are you observant and skillful enough to get a "fix" on all the aircraft, comets, UFOs, etc. that are to be seen in the night sky? You'll find out! Great (unique) mach. lang. sound effects. \$9.95 disk

AIR TRAFFIC CONTROLLER: You won't believe how it feels to control all of an airport's air traffic until you try it! Guide in landings, stop hijackings, avoid UFOs, check computer read-outs, etc. Great explosions and mach. lang. sounds. \$9.95 disk

Any of the above \$9.95, or ALL 5 FOR ONLY \$29.95!

VISA/MASTERCARD accepted

Send To:

AVANT-GARDE CREATIONS
P.O. Box 30161
Eugene, OR 97403
Dept. G1



FORTH

Full FIG-Standard FORTH
for your APPLE II / II+

- **Fast** * Trademark of Apple Computer Corp.
10-20 times faster than most BASICs.
Complete built-in Macro Assembler.
- **Compact!**
Compiled code makes RAM seem larger.
FORTH DOS occupies only 3K.
- **User-Oriented!**
Fully extensible interactive language.
Professionally written tutorial manual.
Advanced Screen Editor.
LORES graphics & String enhancements.
Current, Context & TURNKEY vocabularies.
Single / Dual Drive copy and backup.

\$89.95 Calif. residents add 6%.

MICROMOTION

213-
821-4340

12077 WILSHIRE BLVD. SUITE 506
WEST LOS ANGELES, CA 90025



HAS YOUR APPLE READ ANY GOOD PROGRAMS LATELY? APPLE II DISK SOFTWARE

DATA BASE MANAGER IFO PROGRAM

The IFO (INFORMATION FILE ORGANIZER) can be used for many applications such as: Sales Activity, Check Registers, Balance Sheets, Client/Patient Records, Laboratory Data Reduction, Prescription Information, Grade Records, Mailing Lists, A/R, Job Costing and much more. This can be accomplished without prior programming knowledge.

Up to 1,000 records with a maximum of 20 headers (categories) and 10 report formats (user defined) can be stored on a single diskette, information can be sorted on any header, both ascending and descending in alpha/numeric field. Mathematical functions can be performed on any 2 fields to manipulate the information. Information can be searched on any header using >, <, =, >, =, <, =, and first letter. Mailing list format provided. Fast assembly language Sort, Search and Read routines. Many error protection devices provided. Put your application program together in minutes instead of hours.

Program Diskette and Instruction Manual.....\$100
Mailing List Program and Instruction Manual.....\$40

INVENTORY PROGRAM

2 disk drives, menu-driven program. Inventory categories include: Stock#, Description, Vendor ID, Class, Location, Reorder Pt., Reorder Qty., Qty. on Hand. All records can be entered, changed, updated, deleted, or viewed. Reports can be sorted in ascending/descending order by any category. There are 7 search reports (3 automatic). Calculates \$ VALUE of inventory and YTD, MTD, and period items sold, accumulates inventory over a 13-month period. Requires a 132-column, serial/parallel printer, total turnkey operation with bootstrap diskette.

Program Diskette and Instruction Manual.....\$140

PAYROLL PACKAGE *

2 disk drives, menu-driven program. Employee history include: Name, Address #, Address #2, City, State, Zip, Federal Exemption, State Exemption, Social Security #1, Date Employed, Dept. #, Code, Employee #, Status, Marital Status, Pay Rate, OT Rate, Vacation Rate, # Vacation Hours and Pension Plan. Program can generate weekly or biweekly payroll. Prints W-2, Qtr. Report, Pay Checks, Master and Current Files. Federal and State withholding taxes are built into program. Maintains a Cash Disbursement Journal, accumulates payroll for a 53-week period. Generates numerous type of payroll reports. Allows data to be searched, sorted and edited. Prints Deduction Register and more. Maintain up to 125 Employees/Expenses for quick and easy Payroll. Numerous error protection devices provided.

Program Diskette and Instruction Manual.....\$240

*PLEASE SPECIFY STATE WHEN ORDERING

APARTMENT MANAGER

2 disk drives, menu-driven program written in assembly language and APPLESOFT II. All you will ever need to manage your apartment. Handles up to 6 Buildings with a maximum of 120 units each. Complete turnkey operation. Data categories include Apt. #, Type, Tenant Name, Pets, Children, Security Deposit, Pet Deposit, Pool Deposit, Misc. Deposit, Rent Allowances, Date Moved In, Vacancy Date, Referral, Condition of Apt., Damage Amt. and Comment Line. Search, sort, enter, edit and vacate tenants. Maintains MTD and YTD rent receipts as well as complete utility reports, rent lost by vacancies. Maintains Expenses, Vacated Tenants Report and much more.

Program Diskette and Instruction Manual.....\$325

PROFESSIONAL TIME AND BILLING

2 disk drive program written in assembly language and APPLESOFT II. Completely menu driven. Maintain all billing of clients and personnel. Generates and invoices. Numerous reports based on all types of criteria. Easy data entry for Rates, Clients, and Matters. Has Search, Sort, Change (on screen editing), View and Balance Forward. If you are a Job Contractor, Attorney, Accountant, General Consultant, or anyone that needs to charge for time, this program is a must. Complete turnkey operation. Many Reports are produced to aid in the Time Analysis Process.

Program Diskette and Instruction Manual.....\$325

ALL PROGRAMS REQUIRE 48K and APPLESOFT II ON ROM OR AND APPLE II PLUS. ALL SOFTWARE IS COMPATIBLE WITH PASCAL SYSTEMS. PROGRAMS RUN FROM ANY PORT OF THE COMPUTER WITH SERIAL/PARALLEL PRINTERS. REQUIRES 1 DISK DRIVE UNLESS OTHERWISE NOTED.

SEND CHECK/MONEY ORDER or C.O.D. TO:
SOFTWARE TECHNOLOGY for COMPUTERS
P.O. BOX 428
BELMONT, MA 02178

(OR AVAILABLE FROM YOUR LOCAL DEALER)

GRAPHING RATIONAL FUNCTIONS

This general-purpose graphing program for a high-resolution screen—though applied here to graphing rational functions on an Apple II—is simple enough for high school students to use.

Ron Carlson
44825 Kirk Ct.
Canton, MI 48187

This is a general graphing program even though it is applied to graphing rational functions, such as

$$y = \frac{x(x-4)(x+3)}{(x-1)(x+5)}$$

If you want to graph any type of function, either remove the denominator function, FN DEN(X), or merely DEF FN DEN (X) = 1. Therefore you could graph $y=x\{\sin(x)\}$ by the following lines:

```
60 DEF FN NUM(X)=X*SIN(X)
70 DEF FN DEN(X)=1
```

This program has evolved from plotting x 's on a printer to the versatile graphics output of the APPLE II. Even the program on the APPLE II went through changes, ranging from graphing with an origin in the center of the screen, graphing any quadrant and choice of scale, to this version of choosing the location of the origin on the screen and the scale. High school students appear to have no difficulty using either of these options.

The program is broken into several parts: first the directions and functions section explains to the user how to define the numerator and denominator functions and how to use the program. Any legal BASIC expression can be used for the definition of the numerator

and denominator. Any non-rational function can be graphed by DEF FN DEN(X)=1. I chose the definition method of inputting the function to make the program more easily transferable to other versions of BASIC.

Another section needed for the preparation is for arrangement of the scale and determination of the location of the origin. I use the low-resolution screen with a colored cursor in the center. The user can move the cursor up, down, left, or right by using the

following keys: U, D, L, R, and F when finished. The relative final position of the cursor (A,B) is changed to represent the location of the origin on the high-resolution grid of 280 x 192.

The main body of the program is the graphing section. In order to graph functions, two problems had to be overcome. The first is that the upper left corner of the screen is the origin, making it effectively upside down. The second is that I wanted to have different origins for different applications.

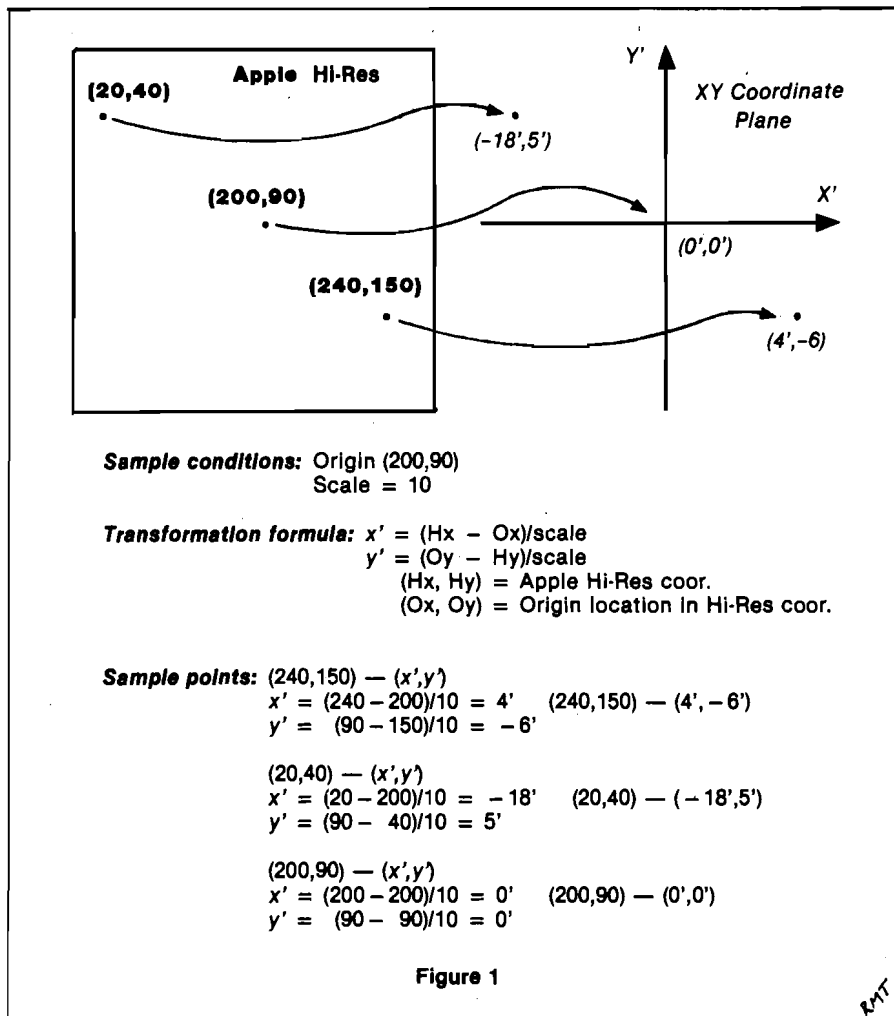

A mathematical transformation formula will change the HGR coordinates to x and y or x and y to HGR coordinates.

$$\{\text{real } x \text{ coord.}\} = \{\text{HGR } x \text{ coord.}\} - \{x \text{ coord. of origin}\}$$

$$X = H - A$$

$$\{\text{real } y \text{ coord.}\} = \{y \text{ coord. of origin}\} - \{\text{HGR } y \text{ coord.}\} \text{ and } Y = B - V.$$

When the scale factor, S , is considered, then the transformation formulas look like:

$$X = (H - A) / S$$

$$Y = (B - V) * S$$

The strategy for graphing is to start H , the HGR coordinate, at 0 and continue the loop until H is 279. Translate H to the real x coordinate and substitute X into the function. Check for an asymptote, and solve for the real y -coordinate. The transformation formula will give the HGR vertical coordinate, which can be checked to make sure it is on the screen, and plot the point. When the graphing loop is finished POKE -16302,0 displays the bottom portion of the screen. The graph stays on the screen until the user depresses any key, thus giving plenty of time to make any important notes. The user is offered the choice of keeping the same function and changing the position of the origin and changing the detail by means of the scale, or starting over with a new function.

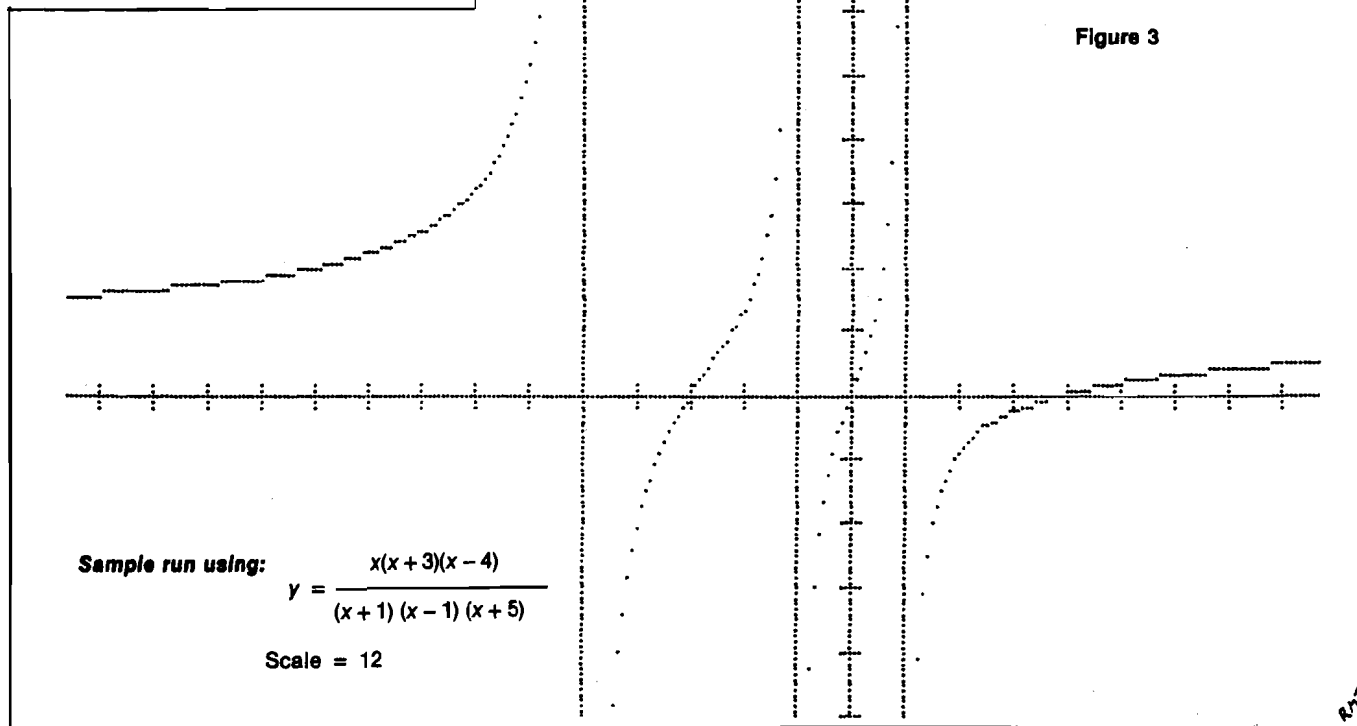
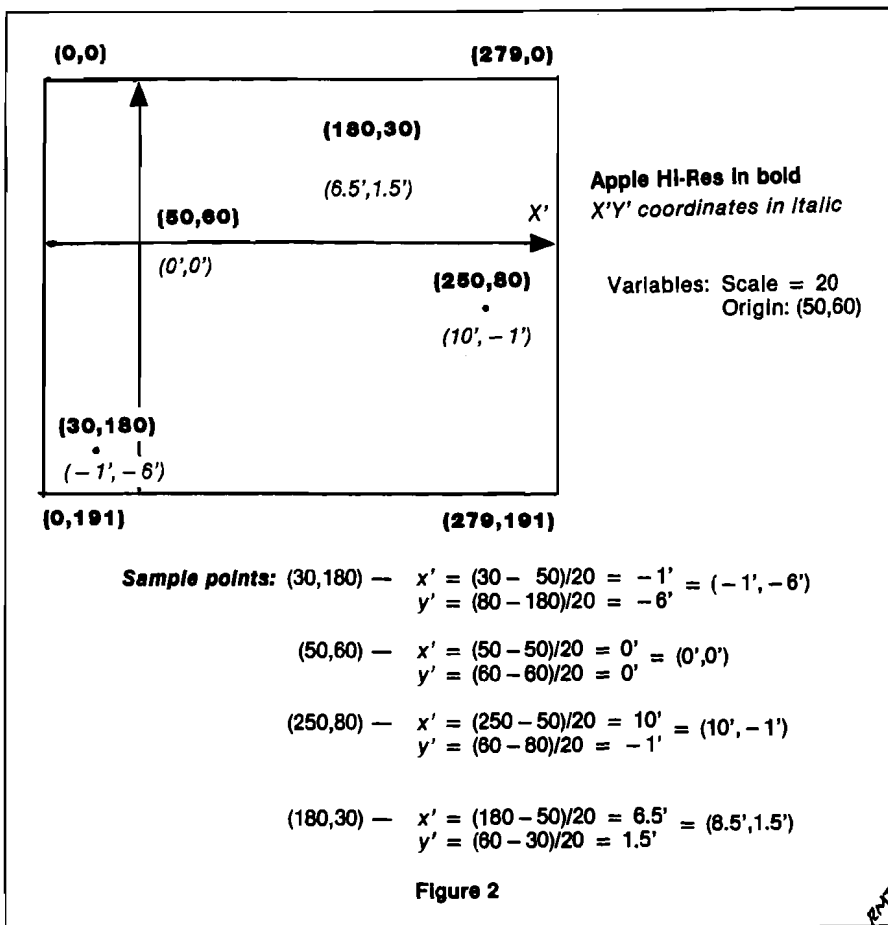

Listing 1

```

10 REM GRAPHING RATIONAL FUNCTIONS
20 REM BY RON CARLSON
50 REM
60 GOTO 440: REM THE NUMERATOR FUNCTION IS TO BE AT LINE 60
70 REM PLACE DENOMINATOR FUNCTION HERE
80 REM DEF FN DEN(X)=1 >> IF YOU HAVE A NON-RATIONAL GRAPH
90 HOME:INPUT"THESE ARE 280 HORIZONTAL DOTS. HOW MANY DOTS/UNIT DO YOU WANT?";S
100 VTAB 21: PRINT "INDICATE THE INTENDED LOCATION OF THE ORIGIN BY MOVING THE CURSOR WITH THE L R U D KEYS FINISHED"
110 REM THIS ALLOWS THE USER TO SELECT WHICH AREA OF THE GRAPH TO VIEW.
120 GOSUB 620: REM TO POSITION THE ORIGIN
130 REM S WILL BE THE SCALE
140 REM DETAIL INCREASES AS S INCREASES
150 VTAB 21:PRINT"AFTE THE BOTTOM HALF OF THE GRAPH IS FINISHED, HIT ANY KEY"
160 PRINT "THERE IS A HASH MARK ON THE AXIS FOR EACH UNIT"
170 HGR : HCOLOR= 7
180 REM AXIS, WITH THE REAL ORIGIN AT (A,B)
190 HPLOT 0,B TO 279,B: HPLT A,0 TO A,191
200 REM HASH MARKS EVERY UNIT ON THE AXIS
210 FOR H = A TO 279 STEP S: HPLT H,B - 2 TO H,B + 2: NEXT
220 FOR H = A TO 0 STEP -S: HPLT H,B - 2 TO H,B + 2: NEXT
230 FOR V = B TO 191 STEP S: HPLT A - 2 ,V TO A + 2,V: NEXT
240 FOR V = B TO 0 STEP -S: HPLT A - 2 ,V TO A + 2,V: NEXT
250 REM ACTUAL GRAPHING
260 FOR H = 0 TO 279
270 REM TRANSFORM THE HGR COOR TO THE REAL VALUE
280 X = (H - A) / S:D = FN DEN(X)
290 REM DRAW THE VERTICAL ASYMPTOTES IF NECESSARY
300 IF D = 0 THEN HCOLOR = 3: HPLT H,0 TO H,191: HCOLOR= 7: GOTO 350
310 Y = FN NUM(X) / D:V = B - Y * S
320 REM TRANSFORM THE REAL Y VALUE TO HGR AND SEE IF IT IS STILL ON THE SCREEN
330 IF V > 191 OR V < 0 THEN 350
340 HPLT H, V
350 NEXT H
370 REM THIS POKE WILL DISPLAY THE BOT

```

```

OM QUARTER OF THE GRAPH
380 POKE - 16302,0: GET A$
390 TEXT : HOME
400 INPUT :DO YOU WANT TO SHIFT THE ORIGIN AND CHANGE SCALE? ";A$
410 IF A$ = "Y" OR A$ = "YES" THEN 90
420 GOTO 830
440 HOME : PRINT "DIRECTIONS FOR RATIONAL FUNCTIONS"
450 PRINT"YOU MUST DEFINE YOUR FUNCTION IN TERMS OF NUMERATOR AND DENOMINATOR"
460 PRINT "FOR EXAMPLE IF YOU WISH TO GRAPH THE FOLLOWING:"
470 PRINT " (X-1)(X+2)"
480 PRINT " Y = -----"
490 PRINT " X(X-7)"
500 PRINT : PRINT "YOU WOULD TYPE THE FOLLOWING"
510 PRINT "60 DEF FNNUM(X)=(X-1)*(X+2)"
520 PRINT "70 DEF FNDEN(X)=X*(X-7)"
530 PRINT "RUN"
540 PRINT : FLASH : PRINT "REMEMBER : "
550 PRINT "60 DEF FNNUM(X)=";: NORMAL : PRINT " LEGAL BASIC EXPRESSION"
560 FLASH: PRINT "70 DEF FNDEN(X)=";: NORMAL: PRINT "LEGAL BASIC EXPRESSION"
570 PRINT "RUN"
580 GOTO 830
600 REM POSITIONING THE ORIGIN ON THE SCREEN (40 BY 40)
610 REM USING L R U D AND F
620 GR : COLOR= 3: PLOT 20,20:A = 20:B + 20
630 GET A$
640 A1 = A:B1 = B
650 IF A$ = "U" THEN B = B - 1: GOTO 710
660 IF A$ = "D" THEN B = B + 1: GOTO 710
670 IF A$ = "L" THEN A = A - 1: GOTO 710
680 IF A$ = "R" THEN A = A + 1: GOTO 710
690 IF A$ = "F" THEN 800
700 REM KEEP ON THE LOW RES SCREEN
710 IF B < 1 THEN B = 1
720 IF B > 39 THEN B = 39
730 IF A < 1 THEN A = 1
740 IF A > 39 THEN A = 39
750 REM BLANK OLD POSITION
760 COLOR= 0: PLOT A1,B1: COLOR= 3
770 REM PLOT NEW POSITION
780 PLOT A,B
790 GOTO 630
800 A = 7 * A:B = B * 192 / 40
810 REM CHANGE SCALE TO REFLECT HGR (280 BY 192)
820 TEXT : HOME : RETURN
830 END

```

MICRO

STONEWARE MICROCOMPUTER PRODUCTS

1930 Fourth Street, San Rafael, CA 94901 (415) 454-6500

Finally . . .
The Hi-res Baseball that's as good as the Apple!
by Arthur Wells

\$24.95/32K/Disk/Applesoft or Integer

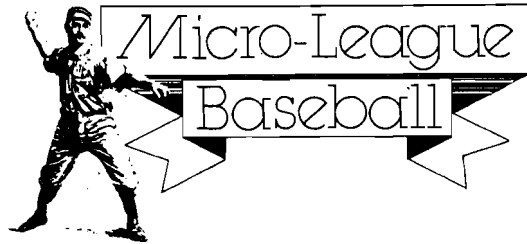

- 8 different pitches, 6 different swings
- 3-D effect on fly balls
- Player controlled fielding and throwing
- Vocal umpire
- Complete electronic score board
- Beautiful stadium in full color

A great hi-res lunar lander,
just like the arcade game!
by Bill Budge creator of Trilogy
and Penny Arcade

\$24.50/48K/Disk/Applesoft or Integer

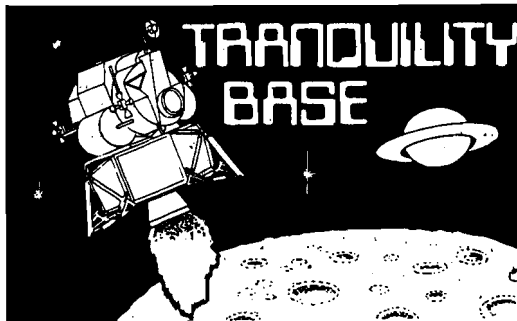

- Landscape scrolling
- Auto-zoom for landing site close-up
- Player control of 360° craft rotation
- Spectacular crashes
- Always challenging . . .
Improve your scores as you improve your skill!

Calif. Residents Add 6% Sales Tax. No C.O.D.'s. Add \$2.00 for Shipping & Handling. Use Check, Money Order, VISA or MASTERCARD. (We need expiration date on charge card.) DEALER INQUIRIES INVITED.

APPLE II is a registered trademark of Apple Computer, Inc.

GALAXY SPACE WAR I

Galaxy Space War 1 (WAR1) is a game of strategy in which the player has complete control of his space fleet's tactical maneuvers. Each fleet battles its way toward the opponents galaxy in an attempt to destroy it and win the war. WAR1 simulates the actual environment encountered in a space war between two galaxies. Optimum use is made of Apple's high resolution graphics (HIRES) and colors in displaying the twinkling stars universe, the colored ships of each fleet, long range sensors colored illuminations, and the alternating blinking colors used in battles between ships. Complementing HIRES are the sounds of war produced by Apple's speaker.

WAR1 is played between Apple and a player or between two players. You may play with total knowledge of each others fleet or only ships sensor knowledge of the opponents fleet. Each player builds his starting fleet and adds to it during the game. This building process consists of creating the size and shape of each ship, positioning it, and then allocating the total amount of energy for each ship.

During a player's turn he may dynamically allocate his ships total energy between his screen/detection and attack/move partitions. The percentage of the total energy allocated to each partition determines its characteristics. The screen/detection partition determines how much energy is in a ship's screens and the detection sector range of its short range sensors. The attack/move determines the amount of energy the ship can attack with, its attack sector range, and the number of sectors it can move in normal or hyperspace.

When an enemy ship is detected by short range sensors, it is displayed on the universe and a text enemy report appears. The report identifies the ship, its position, amount of energy in its screens, probable attack and total energy, a calculated detection/attack/move range, and size of the ship. Also shown is the number of days since you last knew these parameters about the ship. When a ship's long range sensor probes indicate the existence of an enemy presence at a sector in space, this sector is illuminated on the universe.

An enemy ship is attacked and destroyed with attack energy. If your attack energy breaks through his screens, then his attack energy is reduced by two units of energy for every unit you attack with. A text battle report is output after each attack. The program maintains your ship's data and the latest known data about each enemy ship. You may show either data in text reports or display the last known enemy positions on the universe. You can also get battle predictions between opposing ships. The text output calculates the amount of energy required to destroy each ship for different energy allocations.

APPLE® II, 48K, APPLESOFT
ROM CARD, DISK II DOS 3.2
WAR1 DISK & MANUAL ...\$39.95
(CA residents add 6% sales tax)

GALAXY
DEPT. M13
P.O. BOX 22072
SAN DIEGO, CA 92122
(714) 452-1072

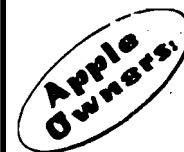

DEPRECIATION PROGRAM

- ★ 5 DEPRECIATION RATES
- ★ UP TO 99 YR TERM
- ★ RECORDS UP TO 600 ITEMS ON DISK
- ★ UP TO \$1 MILLION FOR EACH ITEM
- ★ REPORTS EACH MONTH, QUARTER, OR ANNUALLY
- ★ BONUS DEPR., INVESTMENT CREDIT
- ★ PRO-RATES DEPRECIATION
- ★ UPDATE RECORDS EACH YEAR
- ★ EQUIPMENT INVENTORY
- ★ FISCAL YEAR BASED
- ★ CONVERT METHODS ANY TIME
- ★ AN ACCOUNTANTS DREAM

APPLESOFT 32K MIN. ~~\$225.00~~ \$150.00
HANDBOOK \$5.00

INTRODUCTORY OFFER

VISA & M/C USERS - CALL
509-943-9004

MONEYDISK
516 WELLSIAN WAY
RICHLAND, WA 99352



APPLE IS A REGISTERED TRADEMARK
OF APPLE COMPUTER, INC.
WA Residents, add 5% sales tax

DEALER INQUIRIES INVITED



A C1P User's Notebook

Here are "secrets" of the Challenger—one user's notes on graphics, ACIA, and tape control—which may save you time and frustration.

Robert L. Elm
446 Rothbury Ave.
Bolingbrook, IL 60439

In the last year, I have developed a notebook of things Ohio Scientific didn't tell me about my C1P. Perhaps I can share some of this information with you and save you frustrations.

Getting Started

The dealer showed me how to hook everything up, and verified that it worked. When I got home I couldn't even load the demonstration tape without errors! I was almost ready to take it back when a friend suggested I plug only one cord into the recorder at a time. Suddenly it worked! It seems my recorder feeds noise or something around within itself if the input cord is plugged in while playing a tape. The resulting interference causes errors. The solution is either to build a switch box, or simply plug in one cord at a time.

After I got by that one, I found that I could not SAVE a program without errors. This problem took a couple of days to diagnose, since I didn't know if the trouble was in the SAVE or subsequent LOAD.

I hadn't modified my T.V. monitor yet to limit the scan width so I was responding to the "TERMINAL WIDTH" prompt with "23". I noticed that the errors occurred only on long lines such as PRINT statements. Somehow the line feed at 23 characters (rather than the software supplied 24) disturbs synchronization of the LOAD

routine. The solution is not to narrow the terminal width. Instead, I got busy and narrowed the T.V. scan width by making a minor adjustment in the T.V. horizontal circuitry.

Graphics

Once I started playing with the graphics, I noticed many symbols that can be added together to form larger objects. Notebook Item 1 lists those I have noted and there may be more. At any rate, it would have been nice if Ohio Scientific had told us what it had in mind with the original graphic design, rather than making all the users hunt and guess for themselves.

To see what the graphic symbols look like, you can POKE them to successive screen locations or use PRINT CHR\$(xxx). If you do the latter, you will find there are certain decimal values that will not print via CHR\$. The reason is, they are control codes in ASCII for use with a printer. There are three of these:

CHR\$(7) = Bell
CHR\$(10) = Line Feed
CHR\$(13) = Carriage Return

Another handy piece of information concerns the cursor. Its value is 95 and its "home residence address" is D.54117. If you break this into the two-byte decimal format you will get 211 for the high byte and 101 for the low byte. The low byte is stored in memory at D.512 and is incremented to keep track of the cursor location as it is moved. This information should inspire some thoughts about the possibilities of cursor control in your program.

PEEKing and POKEing Around

Several authors have expanded on the memory map in the pages of MICRO so I won't go over available information. However, it would have been helpful if the operating manual had revealed where the MEMORY SIZE and TERMINAL WIDTH data are stored during a cold start. If you have something already in memory, upper memory can be reserved by POKEing a new value into D.133, D.134; and the terminal width can be changed by POKEing into D.15. This beats saving the program on tape and reloading it after another cold start.

Item 1:

Decimal Values

5 + 6
7 + 8
9 + 10
11 + 12
181 + 182 + 179 + 6
7 + 182 + 179 + 180
232 + 234 + 235 + 232
196 + 234 + 235 + 198
173 + 234 + 235 + 174
244 + 234 + 235 + 247
243 + 234 + 235 + 246
242 + 234 + 235 + 245

Graphic Object Description

Submarine - left side
Submarine - right side
Starship Enterprise - left side
Starship Enterprise - right side
Battleship - left side
Battleship - right side
Spacecraft
Spacecraft
Spacecraft
Spacecraft with aimable guns
Spacecraft with aimable guns
Spacecraft with aimable guns

Understanding The Cassette Port

Very little has been written on the internal workings of the cassette port. The memory map only states its address as hex F000-F001. This equates to decimal 61440-61441. One of my earlier programming projects was to teach my C1P to send Morse Code using the cassette port audio tone. It normally rests at 2400 cycles, and I found I could shift it to 1200 cycles and back again using POKE statements into 61440. My program ultimately worked well except that after running it, the SAVE function operated strangely and I had to warm start it to solve the problem. Investigation led back to the cassette port itself and resulted in more notebook entries.

The ACIA is a 6850 chip which is programmable and contains four accessible registers. The Transmit Data Register is a *write only* register used to send data out to tape. It is accessible using POKE 61441. The same address also contains the Receive Data Register where each word is stored as it comes in from tape. It is a *read only* register and is accessible using PEEK [61441].

The Status Register is a *read only* register you can access by PEEK (61440). Its layout is shown in Notebook Item 2. Bits 2 and 3 reflect the state of pins 23 and 24. In our circuit they are tied to ground, so they should always read zero. Bit 7 reflects the state of pin 7 which is a no-connect in the C1P. However, it can be set internally so don't write it off. The rest of the bits appear to be strictly status-reporting as defined in Item 2.

The Control Register is perhaps the most important in terms of using the cassette port in your programs. It is *writable* using POKE 61440 and it is here that I got into trouble with my Morse Code program.

The layout for this register is shown in Item 3. Bits 0 and 1 control an internal clock divider to allow a software selectable ratio of 1/1, 1/16 and 1/64. The clock supplied to the 6850 will support a 4800-baud data rate so the data rates shown in Item 3 are available.

A quick look at the C1P schematic reveals that the RS-232 circuitry is controlled by the clock output from the 6850. Therefore, if you have access to a 4800-baud printer, a quick POKE into D.61440 will allow full-speed printing! The same is true for 75 baud, if you happen to have an old "100 speed" printer lying around.

Incidentally, the Master Reset sets up a condition the SAVE software is not designed to handle. If you go to the SAVE mode while these bits are both set, the C1P will lock up waiting for the Status Register to change state. I have found that this can also happen while POKEing other values into

61440, but there is a way around it. POKE the Control Register to a decimal 3 followed immediately by the value you want. This can be done by multiple statements per line. For example, POKE 61440, 3: POKE 61440, 16 will set up the 4800-baud rate.

Item 2:

ACIA Status Register				Hex F000	Decimal 61440	READ ONLY		
7	6	5	4		3	2	1	0
IRQ	PE	OVRN	FE		CTS	DCD	TDRE	RDRF

- RDRF - Receive Data Register Full = 1, Reset by data read or reset
- TDRE - Transmit Data Register Empty = 1
- DCD - Data Carrier Detect = 1 for loss of carrier
- CTS - Clear To Send = 1 if pin 24 goes high
- FE - Framing Error = 1 if first stop bit is missing indicating character synchronization error, bad transmission, or a Break condition. Bit resets when condition clears.
- OVRN - OVerRuN error = 1 if RDRF = 1 when next character arrives. Reset by data read.
- PE - Parity Error = 1 if parity of received data does not agree with preselected odd or even parity.
- IRQ - Interrupt ReQuest = 1 to generate interrupt via pin 7. Set by $\overline{\text{DCD}}$ = 1, TDRE = 1 or RDRF = 1 depending on how TC bits of Control Register were set.

Item 3:

ACIA Control Register				Hex F000	Decimal 61440	WRITE ONLY		
7	6	5	4		3	2	1	0
RIE	TC2	TC1	WS3		WS2	WS1	CDS2	CDS1

CDS2 CDS1 Clock Divide Select bits

0	0	1/1 (4800 Baud)
0	1	1/16 (300 Baud - normal for C1P)
1	0	1/64 (75 Baud)
1	1	Master Reset - clears Status Register

WS3 WS2 WS1 Word Select bits

0	0	0	7 Bit + Even Parity + 2 Stop Bits
0	0	1	7 " + Odd " + 2 " "
0	1	0	7 " + Even " + 1 " "
0	1	1	7 " + Odd " + 1 " "
1	0	0	8 " + No " + 2 " " (Normal for C1P)
1	0	1	8 " + No " + 1 " "
1	1	0	8 " + Even " + 1 " "
1	1	1	8 " + Odd " + 1 " "

TC2 TC1 Transmitter Control bits

0	0	Sets RTS = 0 and inhibits transmit mode interrupt output.
0	1	Sets RTS = 0 and enables " " " "
1	0	Sets RTS = 1 and inhibits " " " "
1	1	Sets RTS = 0 and inhibits " " " "

Also transmits Break (Shifts cassette port tone to 1200 cycles)

RIE Receiver Interrupt Enable = 1 to enable interrupt output in receiving mode. Allows RDRF to generate IRQ.

The Word Select bits allow the variable word characteristics shown in Item 3. The C1P software sets WS3 only and supports only that configuration from tape, so I have never had a reason to change it.

The two Transmit Control bits can be used to shift the cassette port tone from 2400 to 1200 cycles and back. When both bits are set, a break is transmitted and the shift to 1200 cycles takes place. Any other value shifts it back. Normally, the C1P software initializes these bits to zeros.

The Receive Interrupt Enable bit is the last one in the Control Register. It is initialized to zero and setting it will cause a corresponding change in the Interrupt Request bit of the Status Register. I haven't found out if the C1P software uses it.

Using the above information, Item 4 shows the correct data to POKE into 61440 to get only the reaction you want.

Reading A Tape Without Loading It

Often I find I want to load more than one program into memory. Since Ohio Scientific allowed for separate LOAD and NEW commands, I only

have to be sure the statement of numbers of the different programs do not overlap. A problem arises in trying to find the start of a program if there is more than one program on a tape. I can only read the tape using Load and that puts it in memory automatically, perhaps destroying what is already there.

The solution is the one line program of Item 5. I assigned it statement number 63999, so it can stay in memory and probably never get overwritten. It takes advantage of the WAIT function in Ohio Scientific 8K BASIC

and capitalizes on the fact that all data is stored in ASCII form on tape. RUN 63999 gets it going for perfect copy without entering anything in memory, and "CTRL C" or RESET and a warm start stops the program when you have found the right spot on the tape. LOAD then functions normally.

I hope you are able to use some of these thoughts and comments. Perhaps you have found something that allows the completion of a stubborn program or application. If so, that is what I intended and I hope you will share your notes with the rest of us C1P users.

Item 4:

```
POKE 61440, 3 to reset Status Register (followed by POKE to valid state)
" " , 17 to initialize normal C1P state
" " , 16 for 4800 baud data rate
" " , 18 for 75 baud (100 speed) data rate
" " , 113 to shift cassette port tone to 1200 cycles (actually anything
from 96 to 127 will work as long as you shift back with a 17)
```

Item 5:

```
Tape Reader
63999 WAIT 61440,1: PRINT CHR$(PEEK (61441));: GOTO 63999
```

OSI C4P OWNERS

DISCOVER
"THE MISSING LINK"
WITH
CYBER—SMART¹

THE INTELLIGENT TERMINAL PROGRAM

OTHER PERSONAL COMPUTER SYSTEMS
COMMUNICATE WITH THE SOURCE² OR MICRONET³
LARGE MAIN FRAME COMPUTERS

— SOFTWARE FEATURES —

- ▶ UPLOAD AND DOWNLOAD BASIC PROGRAMS
- ▶ ACCOMMODATES MULTIPLE INDEPENDENT BASIC PROGRAMS IN MEMORY
- ▶ SCREEN TRANSMIT AND RECEIVE
- ▶ KEYBOARD CONTROLLED SCREEN CLEAR AND COLOR SELECTION
- ▶ FULL DUPLEX, SELECTABLE PARITY, ONE OR TWO STOP BITS

USE OF CYBER—SMART¹ ON OSI C4P SYSTEMS REQUIRES A MODEM AND A SIMPLE MODIFICATION TO THE CPU BOARD. FOR THE MODEM INTERFACE, A KIT CONTAINING ALL THE NECESSARY HARDWARE AND DETAILED INSTRUCTIONS IS INCLUDED. REQUIRES A MINIMUM OF 8K OF MEMORY.

SOFTWARE AND HARDWARE	\$39.95
SOFTWARE (CASSETTE) ONLY	29.95
HARDWARE ONLY	14.95

 **CYBER**
Associates Inc

P.O. BOX 4187 DEPT. M, HUNTSVILLE, ALABAMA 35802

¹ The Source is a trademark of Source Telecommunications, Inc.
² Micronet is a trademark of CompuServe, Inc.

ALL ABOUT OSI BASIC-IN-ROM

BASIC and MONITOR Reference Manual

Aardvark Journal: "It is the book you were hoping was packed with your computer at the factory."
PEEK 65: "...goes far enough...to hold the interest of advanced programmers..."

All statements and commands are explained. Loops. Arrays. Bugs. Tapes. BASIC, Auto-Load and homemade.

USR(X). Floating Point. Variable tables. Binary Structure of Source Code. Maps of pages \$00, 01, 02, FE, FF. Location of routines at \$A0—BF.

From your OSI dealer or software house, or send check to me, \$8.95 postpaid. (COD is \$1.10 extra.)

E.H. Carlson
3872 Raleigh Drive
Okemos, MI 48864

What?
 You own
 a PET and you
 haven't received this
 brand new catalogue?



...being ye compleat
 catalogue of peripherals
 available for your PET

Software
 Peripherals. Books.
 Over 60 items. From
 \$1.00 to \$1250. 24 Pages
 Write to Skyles today for
 your FREE catalogue

Skyles Electric Works
 231 E South Whisman Road
 Mountain View, CA 94041

**Give an ear to your computer
 this Christmas!**

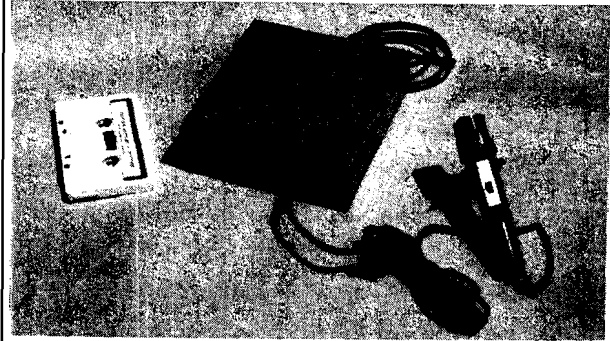

PET or AIM-65

COGNIVOX SR-100 lets your computer respond to your spoken commands! For the first time speech recognition is available for the PET and the AIM-65, adding an exciting dimension to these popular microcomputers. COGNIVOX can be trained by the user to understand words from a vocabulary of up to 32 words with a recognition rate of up to 98% (AIM-65 with 4K of RAM, 16 words). COGNIVOX comes complete with microphone, cassette with software and manual, housed in a quality molded cabinet, yet costs only **\$119**. A fantastically low price for what is simply the best under \$500 speech recognizer in the market today. COGNIVOX is the most exotic and most fun peripheral you can get and it is sure to make your computer the center of attention in your holiday gatherings. Order your COGNIVOX today! Please add \$3 for shipping (CA add 6% tax) and don't forget to give us the model of your computer. Foreign orders welcome, add 10% for handling and shipping by air.

VOICETEK

Dept. M, P.O. Box 388, Goleta, Ca 93017

SIRIUS SOFTWARE

E-Z DRAW. It started as the best graphics editing package available for the APPLE and with our continuing support it is going to stay the best. Human engineered for ease of use and a tutorial intended to be used by computer novices. Still only \$34.95. E-Z DRAW requires a 48K APPLE with Applesoft in ROM or a Language System. Written by Jerry Jewell and Nasir/Gebelli.

STAR CRUISER — The ULTIMATE ACTION game! A real time hi-res action game with sound, action and suspense. Finally a game that requires fast reflexes, coordination and strategy. These critters actually chase you. A game for all ages and priced right at \$24.95. This game runs under 13 or 16 sector format with 32K RAM. Written by Nasir/Gebelli.

BOTH BARRELS includes two games on the same diskette. **DUCK HUNT** is the traditional hunt from the blind, complete with dogs to retrieve the ducks and even an occasional dog fight to liven up the action. Hi-res, of course. **HIGH NOON** has you pitted against an entire town of **BAD GUYS**. They'll attack from doorways, windows, and even rooftops. Be quick or be dead. This has some of the most interesting graphics effects you'll see on the APPLE. Nine levels of play, one to match any age group. These games have great action, great graphics, and great sound effects. What else could you ask for? **BOTH BARRELS** requires 48K with Applesoft in ROM. Written by Nasir/Gebelli.

SIRIUS SOFTWARE
 1537 Howe Avenue #106
 Sacramento, CA 95825
 (916) 920-8981

APPLE, Applesoft and Language System are products of Apple Computer, Inc. E-Z DRAW and DUCK HUNT include character generation by Ron and Darrel Aldrich and fonts by Ted Cohn and Lawrence You.
 The products listed are all copyrighted © 1980 by SIRIUS SOFTWARE. ALL RIGHTS RESERVED.

Drawing A Line On PET's 80 x 50 Grid

A collection of flexible, machine language routines. Allows plotting of individual points—or lines between pairs of points—using PET's quarter-box graphic characters. Additional features include erasing and screen inversion.

Harvey S. Davis
Dept. of Mathematics
Michigan State University
East Lansing, MI 48824

The purpose of this article is to provide some machine language subroutines, which are callable from BASIC, that will enable the user of a PET personal computer to draw either a point or a line on the screen, at double the resolution of the ordinary screen grid. The point or line drawn may be either plotted or erased.

An interesting feature of these subroutines is that the graphics are drawn on the screen between successive hardware updates of the screen. This means that the "snow" that results when the PET competes with the character generator video RAM will not be present. (For related programs see the interesting articles by Sherburne and Velders given in the bibliography.)

The reader should note that these subroutines are designed for use on a PET with the original ROMs. Extensive use is made of the BASIC input buffer for zero page storage. These variables would have to be relocated. Also there are calls to \$E840 to determine the status of the update of the screen.

Machine Language Subroutines

ADLO	*	\$0001	
ADHI	*	\$0002	
XCHR	*	\$0033	WRITTEN FOR 2.0 ROM'S
XADL	*	\$0034	MOST OF THESE PAGE
XADH	*	\$0035	ZERO ADDRESSES MUST
BFRNXT	*	\$0036	BE CHANGED FOR 3.0
BFFRLO	*	\$0037	BASIC ROM'S.
BFFRHI	*	\$0038	
COUNT	*	\$0039	
XO	*	\$003A	
YO	*	\$003B	
XI	*	\$003C	
YI	*	\$003D	
DX	*	\$003E	
DY	*	\$003F	
XLO	*	\$0040	
XHI	*	\$0041	
YLO	*	\$0042	
YHI	*	\$0043	
XVAL	*	\$0044	
YVAL	*	\$0045	
ZALO	*	\$0046	
ZAHI	*	\$0047	
QUAD	*	\$0048	
FLAG	*	\$0049	
ZTABLE	*	\$004A	
VIAADD	*	\$E840	

1B00	20	88	1F	SNGLPT	JSR	FRSTPT CALLED BY BASIC--
1B03	20	F9	1B		JSR	BFROUT DRAWS SINGLE POINT AT
1B06	60				RTS	(XVAL), (YVAL).
1B10	20	00	1F	LINE	JSR	AIM CALLED BY BASIC--
1B13	20	38	1F		JSR	PREDRW DRAWS LINE FROM
1B16	20	88	1F		JSR	FRSTPT X0,Y0 TO X1,Y1.
1B19	20	60	1F		JSR	DRAW
1B1C	20	F9	1B		JSR	BFROUT
1B1F	60				RTS	
1BF9	AD	40	E8	BFROUT	LDA	VIAADD WAITS FOR
1BFC	29	20			AND	#\$20 HARDWARE UPDATE
1BFE	D0	F9			BNE	BFROUT OF SCREEN
1C00	60			BUFFER	RTS	SUBROUTINE CREATED
						BY "BFFRIN"
						STARTS AT \$1C00.

Display Grids

The PET displays characters on its screen with reference to a 25 x 40 grid. Each screen location is associated with an address in memory, according to the following formula:

$$\text{ADDRESS} = 32 * 1024 + 25 * Y + X$$

X denotes the column ($0 \leq X \leq 39$) and Y denotes the row ($0 \leq Y \leq 24$). The positive x-axis points to the left, while the positive y-axis points down. Thus address $32 * 1024$ is associated with the upper left-hand corner of the screen. I will refer to these conventions as the "screen grid".

In order to discuss the generation of graphics having twice the resolution of the screen grid, I shall use two other grids which I shall call the observer's grids.

The observer's grid positive down is an 80 x 50 grid ($0 \leq X \leq 79$, $0 \leq Y \leq 49$) with the origin in the upper left hand corner, the x-axis proceeding from left to right and the y-axis proceeding from top to bottom.

The observer's grid positive up is an 80 x 50 grid ($0 \leq X \leq 79$, $0 \leq Y \leq 49$) with the origin in the lower left hand corner, the x-axis proceeding from left to right and the y-axis proceeding from bottom to top.

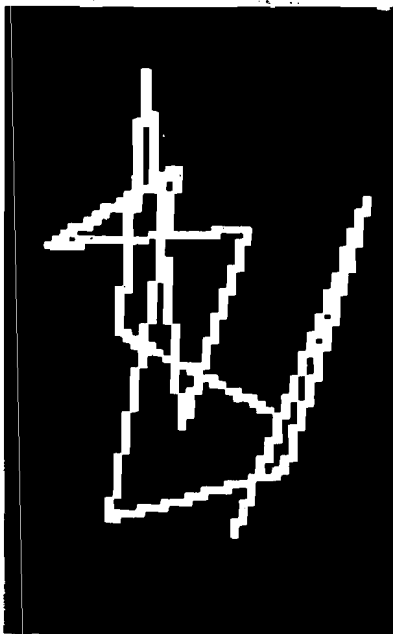

(continued)

1E00 20	TABLE	=	\$20	THIS IS A TABLE OF
1E01 6C		=	\$6C	ALL SIXTEEN POSSIBLE
1E02 7B		=	\$7B	QUARTER-BOX CHAR.'S.
1E03 62		=	\$62	
1E04 7C		=	\$7C	
1E05 E1		=	\$E1	
1E06 FF		=	\$FF	
1E07 FE		=	\$FE	
1E08 7E		=	\$7E	
1E09 7F		=	\$7F	
1E0A 61		=	\$61	
1E0B FC		=	\$FC	
1E0C E2		=	\$E2	
1E0D FB		=	\$FB	
1E0E EC		=	\$EC	
1E0F A0		=	\$A0	
1E10 A2 0F	INIT	LDX	#\$0F	MOVES ABOVE TABLE
1E12 BD 00 1E	LOAD	LDA	TABLE,X	TO PAGE ZERO
1E15 95 4A		STA	ZTABLE,X	BEGINNING AT
1E17 CA		DEX		ZTABLE=\$004A
1E18 10 F8		BPL	LOAD	
1E1A 60	RETURN	RTS		
1E1B A5 44	POINT	LDA	XVAL	COMPUTES SCREEN
1E1D 30 FB		BMI	RETURN	ADDRESS AND ENCODES
1E1F C9 50		CMP	#\$50	CHARACTER QUADRANT
1E21 10 F7		BPL	RETURN	
1E23 A5 45		LDA	YVAL	
1E25 30 F3		BMI	RETURN	TESTS FOR XVAL AND
1E27 C9 32		CMP	#\$32	YVAL IN RANGE
1E29 10 EF		BPL	RETURN	
1E2B 24 49	ORIENT	BIT	FLAG	CHECKS BIT 7 OF FLAG
1E2D 10 07		BPL	PREP	= 0 NO CHANGE
1E2F A9 31		LDA	#\$31	= 1 YVAL = 49 - YVAL
1E31 38		SEC		
1E32 E5 45		SBC	YVAL	
1E34 85 45		STA	YVAL	
1E36 18	PREP	CLC		2 * PARITY(YVAL) +
1E37 A5 45		LDA	YVAL	PARITY(XVAL)
1E39 29 01		AND	#\$01	TRANSFERRED TO
1E3B 0A		ASL	A	X REG.
1E3C 85 46		STA	ZALO	
1E3E A5 44		LDA	XVAL	
1E40 29 01		AND	#\$01	
1E42 65 46		ADC	ZALO	
1E44 AA		TAX		
1E45 A9 10		LDA	#\$10	QUAD = 2 (4-XR+1)
1E47 4A	LOOPA	LSR	A	
1E48 CA		DEX		
1E49 10 FC		BPL	LOOPA	
1E4B 85 48		STA	QUAD	
1E4D 46 44		LSR	XVAL	XVAL = INT(XVAL/2)
1E4F 46 45		LSR	YVAL	YVAL = INT(YVAL/2)
1E51 A9 80	LOCAD	LDA	#\$80	SET ADLO,ADHI FOR
1E53 85 02		STA	ADHI	SCREEN UPPER LEFT
1E55 A9 00		LDA	#\$00	ZALO = 8 * YVAL
1E57 85 01		STA	ADLO	
1E59 85 47		STA	ZAHI	
1E5B A5 45		LDA	YVAL	
1E5D 0A		ASL	A	

```

1E5E 0A          ASL  A
1E5F 0A          ASL  A
1E60 85 46      STA  ZALO  ZAH1,ZALO =
1E62 06 46      ASL  ZALO  4 * ZALO
1E64 26 47      ROL  ZAH1  32 * YVAL
1E66 06 46      ASL  ZALO
1E68 26 47      ROL  ZAH1
1E6A 65 44      ADC  XVAL  ZAH1,ZALO =
1E6C 65 46      ADC  ZALO  ACCUM. + XVAL +
1E6E 85 46      STA  ZALO  ZAH1,ZALO
1E70 90 02      BCC  ADDAD = 40 * YVAL + XVAL
1E72 E6 47      INC  ZAH1
1E74 18          ADDAD CLC
1E75 A5 46      LDA  ZALO  + ADHI,ADLO
1E77 65 01      ADC  ADLO  = $8000 + 40 * YVAL
1E79 85 01      STA  ADLO  + XVAL
1E7B A5 47      LDA  ZAH1
1E7D 65 02      ADC  ADHI
1E7F 85 02      STA  ADHI
1E81 60          RTS

1E88 AD 40 E8  GETCHR LDA  VIAADD  WAITS FOR HARDWARE
1E8B 29 20      AND  #$20  SCREEN UPDATE--
1E8D D0 F9      BNE  GETCHR AVOIDS SNOW!!
1E8F A2 00      LDX  #$00  GET CHARACTER FROM
1E91 A1 01      LDA  (ADLO,X) SCREEN ADLO,ADHI
1E93 85 33      STA  XCHR  STASH IN XCHR
1E95 A5 01      LDA  ADLO  XADL = ADLO
1E97 85 34      STA  XADL
1E99 A5 02      LDA  ADHI  XADH = ADHI
1E9B 85 35      STA  XADH
1E9D 60          RTS

1EA0 A5 33      UPDATE LDA  XCHR  LOOK FOR XCHR IN
1EA2 A2 00      LDX  #$00  ZTABLE
1EA4 D5 4A      LOOPB  CMP  ZTABLE,X
1EA6 F0 06      BEQ  TSTFLG  FOUND
1EA8 E8          INX
1EA9 E0 10      CPX  #$10  AT END OF TABLE?
1EAB D0 F7      BNE  LOOPB
1EAD 60          RTS
1EAE 24 49      TSTFLG BIT  FLAG  TEST FLAG--BIT 6
1EB0 50 0C      BVC  PLOT   =0 PLOT =1 ERASE
1EB2 A9 FF      ERASE  LDA  #$FF  BLANKS QUADRANT
1EB4 45 48      EOR  QUAD  INDICATED BY
1EB6 85 48      STA  QUAD  (QUAD) OF COVERING
1EB8 8A          TXA  CHARACTER (SCHR).
1EB9 25 48      AND  QUAD  TABLE INDEX OF NEW
1EBB AA          TAX  CHAR. NOW IN XR.
1EBC 10 04      BPL  CONT  ACTUALLY UNCOND.!
1EBE 8A          PLOT  TXA  FILLS QUADRANT
1EBF 05 48      ORA  QUAD  INDICATED BY QUAD.
1EC1 AA          TAX
1EC2 B5 4A      CONT  LDA  ZTABLE,X STORES NEW
1EC4 85 33      STA  XCHR  COVERING CHAR.
1EC6 60          RTS

```

(continued)

Character Graphics

The character that is displayed at a given location on the screen is completely determined by the byte value stored at the corresponding address.

Among the characters that the PET makes available are 16 that allow the user effectively to double the resolution simultaneously in each direction. These characters can be visualized as a square with each of its quadrants either blank or lit. Table 1 gives these characters and their byte equivalents.

Table 1

a	b	c	d	value
0	0	0	0	20
0	0	0	1	6C
0	0	1	0	7B
0	0	1	1	62
0	1	0	0	7C
0	1	0	1	E1
0	1	1	0	FF
0	1	1	1	FF

a	b	c	d	value
1	0	0	0	7E
1	0	0	1	7F
1	0	1	0	61
1	0	1	1	Fc
1	1	0	0	E2
1	1	0	1	FB
1	1	1	0	EC
1	1	1	1	AO

a	b
c	d

a=0 if and only if quadrant a is blank
b=0 if and only if quadrant b is blank
c=0 if and only if quadrant c is blank
d=0 if and only if quadrant d is blank

Some Notation Conventions

If XXX denotes an address, then [XXX] will denote the byte value stored at that address. [XXX] may also, in the appropriate context, denote the character represented by that byte value.

If XXX and YYY denote addresses, then (XXX,YYY) will denote the address whose low byte is [XXX] and whose high byte is [YYY]. [XXX,YYY] will denote the double precision number whose most significant byte is [XXX] and whose least significant byte is [YYY].

AC, XR, and YR denote the byte values at the accumulator, the x register and the y register.

BASIC Subroutines (for drawing a single point at X,Y on the observer's grid)

1. Set the observer's grid positive down. This is done by setting the most significant bit of FLAG = \$0049 = 73 to 0.

```
10 POKE 73, PEEK (73) AND 127
: RETURN
```

2. Set the observer's grid positive up. This is done by setting the most significant bit of FLAG = \$0049 = 73 to 1.

```
15 POKE 73, PEEK (73) OR 128 :
RETURN
```

3. Set draw mode to PLOT. This is done by setting the second most significant bit of FLAG to 0.

```
20 POKE 73, PEEK (73) AND 191
: RETURN
```

4. Set draw mode to ERASE. This is done by setting the second most significant bit of FLAG to 1.

```
25 POKE 73, PEEK (73) OR 64 :
RETURN
```

5. Draw the point at X,Y. This is done by setting [XVAL] = X, [YVAL] = Y and calling subroutine SNGLPT.

```
30 POKE 68,X : POKE 69,Y : SYS
(6912) : RETURN
```

(continued)

1EC8 A9 00	SETBFR	LDA	#\$00	ADJUSTS
1ECA 85 36		STA	BFRNXT	BUFFER
1ECC 85 37		STA	BFFRLO	POINTERS
1ECE A9 1C		LDA	#\$1C	
1ED0 85 38		STA	BFFRHI	
1ED2 60		RTS		
1ED8 A4 36	BFRIN	LDY	BFRNXT	BUFFER INDEX
1EDA A9 A9		LDA	#\$A9	= "LDA #"
1EDC 91 37		STA	(BFFRLO),Y	
1EDE C8		INY		
1EDF A5 33		LDA	XCHR	XCHAR IN NEXT
1EE1 91 37		STA	(BFFRLO),Y	BUFFER LOC.
1EE3 C8		INY		
1EE4 A9 8D		LDA	#\$8D	= "STA ABS."
1EE6 91 37		STA	(BFFRLO),Y	
1EE8 C8		INY		
1EE9 A5 34		LDA	XADL	TRANSFER CALC.
1EEB 91 37		STA	(BFFRLO),Y	SCREEN ADDRESS
1EED C8		INY		TO BUFFER PROG.
1EEE A5 35		LDA	XADH	
1EF0 91 37		STA	(BFFRLO),Y	
1EF2 C8		INY		
1EF3 A9 60		LDA	#\$60	= "RTS"
1EF5 91 37		STA	(BFFRLO),Y	BFRNXT POINTS AT
1EF7 84 36		STY	BFRNXT	THIS "RTS".
1EF9 60		RTS		
1F00 A9 80	AIM	LDA	#\$80	SETS POSITIVE
1F02 05 49		ORA	FLAG	DOWN
1F04 85 49		STA	FLAG	
1F06 A5 3C	CMPXI	LDA	XI	MAKES SURE PLOT
1F08 C5 3A		CMP	XO	PROCEEDS IN
1FOA 10 0E		BPL	CMPYI	POSITIVE X
1FOC A6 3A		LDX	XO	DIRECTION
1FOE 85 3A		STA	XO	
1F10 86 3C		STX	XI	
1F12 A5 3D		LDA	YI	
1F14 A6 3B		LDX	YO	
1F16 85 3B		STA	YO	
1F18 86 3D		STX	YI	
1F1A A5 3D	CMPYI	LDA	YI	MAKES SURE PLOT
1F1C C5 3B		CMP	YO	CALCULATIONS
1F1E 10 12		BPL	RTNAIM	PROCEED IN POSI-
1F20 38		SEC		TIVE Y DIRECTION,
1F21 A9 31		LDA	#\$31	IN SPITE OF ACTUAL
1F23 E5 3D		SBC	YI	ORIENTATION.
1F25 85 3D		STA	YI	
1F27 38		SEC		
1F28 A9 31		LDA	#\$31	
1F2A E5 3B		SBC	YO	
1F2C 85 3B		STA	YO	
1F2E 06 49		ASL	FLAG	
1F30 46 49		LSR	FLAG	
1F32 60	RTNAIM	RTS		
1F38 38	PREDRW	SEC		INITIALIZES
1F39 A5 3C		LDA	XI	VARIABLES USED
1F3B E5 3A		SBC	XO	IN LINE
1F3D 85 3E		STA	DX	DRAWING
1F3F 38		SEC		

```

1F40 A5 3D      LDA  YI
1F42 E5 3B      SBC  YO
1F44 85 3F      STA  DY
1F46 A5 3A      LDA  XO
1F48 85 44      STA  XVAL
1F4A 85 41      STA  XHI
1F4C A5 3B      LDA  YO
1F4E 85 45      STA  YVAL
1F50 85 43      STA  YHI
1F52 A2 80      LDX  #$80  PLOTS LINE
1F54 86 40      STX  XLO  FROM XO,YO TO
1F56 86 42      STX  YLO  X1,Y1 BY
1F58 A2 00      LDX  #$00  COMPUTING AND
1F5A 86 39      STX  COUNT PLOTTING
1F5C 60         RTS    256 CONSECUTIVE
                                POINTS

```

```

1F60 A5 3E      DRAW  LDA  DX
1F62 18         CLC
1F63 65 40      ADC  XLO
1F65 85 40      STA  XLO
1F67 90 02      BCC  INCRY
1F69 E6 41      INC  XHI
1F6B A5 3F      INCRY LDA  DY  PLOTS POINT AT
1F6D 18         CLC    XVAL,YVAL.
1F6E 65 42      ADC  YLO
1F70 85 42      STA  YLO
1F72 90 02      BCC  CALLPT INITIALIZE AND
1F74 E6 43      INC  YHI  PLOT FIRST
1F76 A5 41      CALLPT LDA XHI  POINT.
1F78 85 44      STA  XVAL  IS THIS ADDRESS
1F7A A5 43      LDA  YHI  SAME AS THAT
1F7C 85 45      STA  YVAL  OF LAST POINT?
1F7E 20 A0 1F   JSR  NEXTPT
1F81 E6 39      INC  COUNT
1F83 D0 DB      BNE  DRAW  END OF BUFFER?
1F85 4C D8 1E   JMP  BFRIN
1F88 20 10 1E   FRSTPT JSR  INIT
1F8B 20 1B 1E   JSR  POINT
1F8E 20 88 1E   JSR  GETCHR BUFFER TO SCREEN
1F91 20 A0 1E   JSR  UPDATE RESET TO NOMINAL
1F94 20 C8 1E   JSR  SETBFR LAST CHR. TO BUFF.
1F97 20 D8 1E   JSR  BFRIN  CHR. AT NEXT ADDR.
1F9A 60         RTS

```

```

1FA0 20 1B 1E   NEXTPT JSR  POINT
1FA3 A5 01      LDA  ADLO
1FA5 C5 34      CMP  XADL
1FA7 D0 06      BNE  NEWADR
1FA9 A5 02      LDA  ADHI
1FAB C5 35      CMP  XADH
1FAD F0 13      BEQ  TOUPDT
1FAF A9 F5      NEWADR LDA  #$F5
1FB1 38         SEC
1FB2 C5 36      CMP  BFRNXT
1FB4 B0 06      BCS  TOBFFR
1FB6 20 F9 1B   JSR  BFROUT
1FB9 20 C8 1E   JSR  SETBFR
1FBC 20 D8 1E   TOBFFR JSR  BFRIN
1FBF 20 88 1E   JSR  GETCHR
1FC2 20 A0 1E   TOUPDT JSR  UPDATE
1FC5 60         RTS

```

To use the BASIC subroutine for drawing a line from X,Y to U,V on the observer's grid positive up, the draw mode may be set by BASIC subroutines 20 and 25 above. The drawing is done by setting [X0] = X,[Y0] = Y,[X1] = U,[Y1] = V and calling subroutine LINE.

40 POKE 58,X : POKE 59,Y :
POKE 60,U : POKE 61,V

42 SYS(6928) : RETURN

The user should note that if a BASIC program intermixes point and line commands, the orientation of the observer's grid must be reset by either subroutine 10 or 15, before each point command that immediately follows a line command. It need not be reset between successive point commands. The line command (subroutine 40) always assumes that the observer's grid is positive up.

Bibliography

Sherburne, J.R., *High Resolution Plotting for the PET, MICRO* [10:19].

Velders, J.A., *Hi-resolution Plot, Pet User Notes*, vol. 2, #1, p. 18.

MICRO

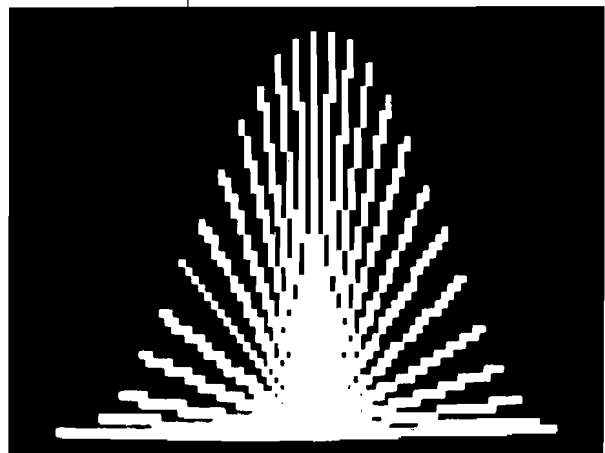

Compare Our Prices With Any Others

Rockwell's	AIM-65	1K System:	\$405.	4K System	\$459.
Synertek's	SYM-1	1K System:	235.	4K System	259.
Commodore's	KIM-1	1K System:	175.		

FOR YOUR SYSTEM'S EXPANSION

The Computerist, Inc's:

16K DRAM	\$279.	Proto Plus II	\$42.
32K DRAM	375.	ASK I/O Board	55.
Video Plus II	279.	DRAM & Video Cable	15.
Mother Plus II & Card Cage	115.	Power Supply for SYM-1	39.

Power Supply and Enclosure for AIM-65	\$119.
Power Supply and Enclosure for KIM-1	65.

All products are factory warranted. Prices include full documentation.

Send Check or Money Order to:

Hepburn MCA*

12 Grosvenor Street
Lowell, MA 01851

Please add \$5.00 shipping and handling. MA residents add 5% sales tax.

** Mini Computers and Accessories*

32 K BYTE MEMORY

RELIABLE AND COST EFFECTIVE RAM FOR 6502 & 6800 BASED MICROCOMPUTERS

**AIM 65-*KIM*SYM
PET*S44-BUS**

- * PLUG COMPATIBLE WITH THE AIM-65/SYM EXPANSION CONNECTOR BY USING A RIGHT ANGLE CONNECTOR (SUPPLIED) MOUNTED ON THE BACK OF THE MEMORY BOARD.
- * MEMORY BOARD EDGE CONNECTOR PLUGS INTO THE 6800 S 44 BUS.
- * CONNECTS TO PET OR KIM USING AN ADAPTOR CABLE.
- * RELIABLE—DYNAMIC RAM WITH ON BOARD INVISIBLE REFRESH—LOOKS LIKE STATIC MEMORY BUT AT LOWER COST AND A FRACTION OF THE POWER REQUIRED FOR STATIC BOARDS.
- * USES +5V ONLY, SUPPLIED FROM HOST COMPUTER.
- * FULL DOCUMENTATION. ASSEMBLED AND TESTED BOARDS ARE GUARANTEED FOR ONE YEAR AND PURCHASE PRICE IS FULLY REFUNDABLE IF BOARD IS RETURNED UNDAMAGED WITHIN 14 DAYS.

ASSEMBLED WITH 32K RAM	\$395.00
& WITH 16K RAM	\$339.00
TESTED WITHOUT RAM CHIPS	\$279.00
HARD TO GET PARTS (NO RAM CHIPS)	
WITH BOARD AND MANUAL	\$109.00
BARE BOARD & MANUAL	\$49.00

PET INTERFACE KIT - CONNECTS THE 32K RAM BOARD TO A JK OR BK PET. CONTAINS INTERFACE CABLE, BOARD STANDOFFS, POWER SUPPLY MODIFICATION KIT AND COMPLETE INSTRUCTIONS. \$49.00

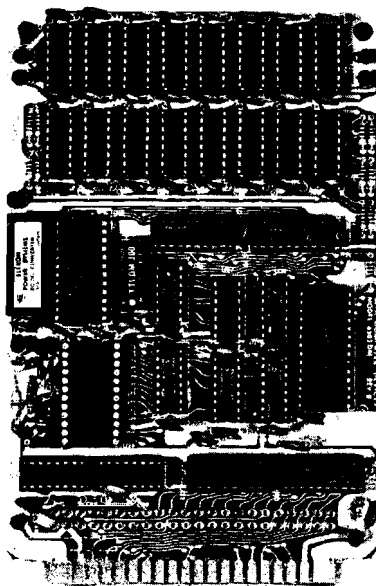

U.S. PRICES ONLY

16K MEMORY EXPANSION KIT

ONLY **\$58**

FOR APPLE, TRS-80 KEYBOARD, EXIDY, AND ALL OTHER 16K DYNAMIC SYSTEMS USING MK4116-3 OR EQUIVALENT DEVICES.

- * 200 NSEC ACCESS, 375 NSEC CYCLE
- * BURNED-IN AND FULLY TESTED
- * 1 YR. PARTS REPLACEMENT GUARANTEE
- * QTY. DISCOUNTS AVAILABLE

ALL ASSEMBLED BOARDS AND MEMORY CHIPS CARRY A FULL ONE YEAR REPLACEMENT WARRANTY

BETA
COMPUTER DEVICES

1230 W. COLLINS AVE.
ORANGE, CA 92668
(714) 633-7280

Calif. residents please add 6% sales tax. Mastercharge & Visa accepted. Please allow 14 days for checks to clear bank. Phone orders welcome. Shipping charges will be added to all shipments.

A Random-Character Morse Code Teacher For The AIM 65

High-speed Morse Code character recognition comes easily when you program your computer to generate code sounds at 13 words per minute and up.

Eugene V. Weiner
511 Fifth Avenue
Coralville, IA 52241
with
Marvin L. DeJong
Dept. of Math & Physics
The School of the Ozarks
Point Lookout, MO 65726
and
Russell V. Lenth
Dept. of Statistics
University of Iowa
Iowa City, IA 52242

In September 1979 I noticed an article¹ by M.L. DeJong in MICRO [16:29]. There was also a Morse Code sending software² offered by the above author. Both were of great interest to me because one of several goals I am working toward is the use of my AIM 65 to send and receive Morse Code. I also wanted to use the AIM 65 to send code lessons.

Some years ago in learning the Morse Code, I decided on a technique for learning and teaching it. By sending the individual characters at a rate greater than 13 w.p.m. (words per minute), with increased spacing to lower the presentation rate, the student would be able to learn the actual character sound sooner, rather than taking the character apart mentally, counting the various dots and dashes, and then deciding which character was sent. At higher code transmission rates (13 w.p.m. and up) character recognition has to be virtually instantaneous.

An accompanying learning problem is lesson material. A recording or tape

of text (even random groups) is soon memorized and its effectiveness is lost. Randomly generated character groups are difficult to memorize and give no clues as to what character may be heard next. I thought this whole approach could be accomplished with a small computer. All that was needed was some software and a little hardware.

An article³ appeared in MICRO February 1980 (21:19) by M.L. DeJong that described a Morse Code send and receive program. I was so impressed that I felt it was time to press forward and have available a random code program to provide the additional tool for teaching Morse Code. I discussed it with a local Amateur Radio operator, Russell V. Lenth, who is quite conversant in BASIC. On short notice he produced a program to generate random character groups, but not in Morse Code. Neither of us knew how to join it with a Morse Code generation program, so I sent a letter to M.L. DeJong detailing what we wished to accomplish, and

included the BASIC program. He was kind enough to write another BASIC program and a machine language program which generally accomplished what was desired. We [R.V. Lenth and I] worked over the two programs to do a number of additional things. Below are listed the functions of the refined program.

1. Characters are generated at 15 w.p.m. or faster.
2. Characters are presented in groups of 5.
3. User has option to input specific characters for random sending.
4. Program provides for the 42 characters available in the look-up Table^{1, 2}.
5. Spacing between characters is varied below 15 w.p.m. to control presentation rate.
6. Program prints each line of characters after the entire line is sent.

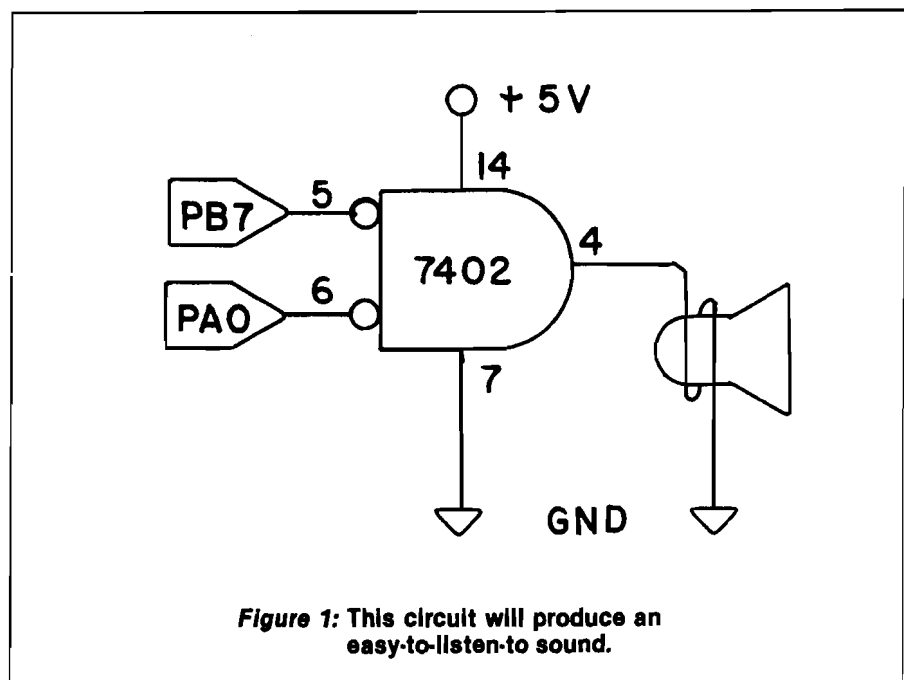

Figure 1: This circuit will produce an easy-to-listen-to sound.

The hardware to generate the code sounds and/or operate an external relay for keying a transmitter or code practice oscillator was taken from several articles by M.L. DeJong^{1,2,3}. We believe there are sufficient hardware options to cover most users' needs. An additional option is shown in figure 1 from a private note from M.L. DeJong, modified by E.V. Weiner.

The machine language program which generates the Morse Code is relatively short. When activating BASIC, limit memory to 2048 bytes. The look-up table is located above \$0F20. The Morse Code send routine starts at \$0F5C.

Look Up Table

```

0F20 00 00 00 00
0F24 00 00 00 CE
0F28 00 00 00 00
0F2C CE 8C 56 94
0F30 FC 7C 3C 1C
0F34 0C 04 84 C4
0F38 E4 F4 16 32
0F3C 00 8C 00 32
0F40 00 60 88 A8
0F44 90 40 28 D0
0F48 08 20 78 B0
0F4C 48 E0 A0 F0
0F50 68 D8 50 10
0F54 C0 30 18 70
0F58 98 B8 C8 00
  
```

RANDOM CHARACTER MORSE CODE

BY EUGENE V. WEINER,
MARVIN L. DEJONG
RUSSELL V. LENTH

FOR THE AIM 65

AIM EQUATES

```

UDRAH * $A001 DATA REG A
UDDRA * $A003 DATA DIR REG A
UTIL * $A004 TIMER 1 COUNTER LOW
UTILA * $A005 TIMER 1 COUNTER HIGH
UACR * $A00B AUX CONTROL REGISTER
DIV * $A497 DIVIDE BY 1024 TIMER
  
```

AIM SUBROUTINES

```

OUTPUT * $E97A OUTPUT A CHARACTER
XXXX * $C0D1
  
```

PROGRAM EQUATE

TABLE * \$0F00

```

                                ORG $0F5C
0F5C A9 81 START LDA #$81
0F5E 8D 01 A0 STA UDRAH
0F61 8D 03 A0 STA UDDRA
0F64 A9 C0 LDA #$C0
0F66 8D 0B A0 STA UACR
0F69 A9 00 LDA #$00
0F6B 8D 04 A0 STA UTIL
0F6E A9 04 LDA #$04
0F70 8D 05 A0 STA UTILA
0F73 A5 38 LDA $0038
0F75 48 PHA
0F76 A8 TAY
0F77 AD 00 0F LDA TABLE
0F7A F0 21 BEQ LBLF
0F7C 0A LBLA ASL A
  
```

```

0F7D F0 0F BEQ LBLD
0F7F 48 PHA
0F80 B0 06 BCS LBLB
0F82 20 A2 0F JSR LBLG
0F85 4C 8B 0F JMP LBLC
0F88 20 BB 0F LBLB JSR LBLK
0F8B 68 LBLC PLA
0F8C D0 EE BNE LBLA
0F8E A0 02 LBLD LDY #$02
0F90 20 C0 0F LBLE JSR LBLL
0F93 88 DEY
0F94 D0 FA BNE LBLE
0F96 68 PLA
0F97 20 7A E9 JSR OUTPUT
0F9A 4C D1 C0 JMP XXXX
0F9D A0 04 LBLF LDY #$04
0F9F 4C 90 0F JMP LBLE
0FA2 A0 01 LBLG LDY #$01
0FA4 CE 01 A0 LBLH DEC UDRAH
0FA7 20 C0 0F LBLI JSR LBLL
0FAA 88 DEY
0FAB D0 FA BNE LBLI
0FAD AD 01 A0 LDA UDRAH
0FB0 4A LSR A
0FB1 B0 07 BCS LBLJ
0FB3 EE 01 A0 INC UDRAH
0FB6 C8 INY
0FB7 4C A7 0F JMP LBLI
0FBA 60 LBLJ RTS
0FBB A0 03 LBLK LDY #$03
0FBD 4C A4 0F JMP LBLH
0FC0 A5 37 LBLL LDA $0037
0FC2 8D 97 A4 STA DIV
0FC5 2C 97 A4 LBLM BIT DIV
0FC8 10 FB BPL LBLM
0FCA 60 RTS
  
```

The basic program allocates memory for the characters to be sent in statements 10 and 20.

- 30 to 50 generate the numbers.
- 60 to 80 generate the letters.
- 100 defaults to all the characters in the look-up table.
- 110 to 140 input desired characters other than default set.
- Speed is entered at 150.
- 151 to 180 provide for character spacing.
- 190 to 200 enter speed values into machine language subroutine.
- 210 to 220 specify starting address for the machine language subroutine.
- 230 to 260 fill the "A" array with 20 random characters.
- 270 to 400 send and display the characters.
- 290 puts characters into memory.

- 300 to 310 generate character spacing.
- 320 sends and displays the characters.
- 330 prints 20 characters after they are sent and displayed.
- 360 to 390 put timed spaces between groups of 5 characters.
- Starting at 410 is a subroutine which determines how many lines of 20 characters are to be sent before stopping and requesting a change in speed.

After the two programs are entered, the BASIC program is initialized. If all 42 characters are desired, the number 42 is entered on Prompt. Any speed may be entered on the speed Prompt. After 100 characters are sent, a speed Prompt will appear. A speed change may then be made which retains the original set of characters specified in either Statement 100 or 110. The number of lines to be sent may be altered by changing "If x=5 then 150" to some other integer value of "x".

This program has been used on a regular basis for several months. People who have listened to the code lessons generated by this program have responded favorably.

We hope to modify the program to enable entering text and having it sent as Morse Code by the variable speed and space routines described above.

Bibliography

1. DeJong, Marvin L., "AIM 65 in the Ham Shack," MICRO, September 1979, (16:29).
2. DeJong, Marvin L., "AIM 65 Morse Code Send Program," MICRO, September 1979, (16:51).
3. DeJong, Marvin L., "A Complete Morse Code Send/Receive Package," MICRO, February 1980, (21:19).

MICRO

Basic Listing 1.

```

10 DIM A(20),C(50)
20 C(1)=44:C(2)=45:
C(3)=46:C(4)=47
30 FOR I=5 TO 16
40 C(I)=I+43
50 NEXT I
60 FOR I=17 TO 42
70 C(I)=I+48
80 NEXT I
90 PRINT"ENTER NUMB
ER OF CHARACTERS DES
IRED":INPUT N
100 IF N=42 THEN 15
0
110 PRINT"ENTER CHA
RACTERS DESIRED":INP
UT A$
120 FOR I=1 TO N
130 C(I)=ASC(MID$(A
$,I,1))
140 NEXT I
150 PRINT"ENTER SPE
ED":INPUT S
151 Z=S:X+0
155 T=1:U=7500/S
160 IF S>14 THEN 19
0
170 T=7500/S-500
180 S=15
190 S=INT(1172/S+.5
)
200 POKE 55,S
210 POKE 04,92
220 POKE 05,15
230 FOR I=1 TO 20
240 J=INT(N*RND(1)+
1)
250 A(I)=C(J)
260 NEXT I
270 J=0
280 FOR I=1 TO 20
290 POKE 56,A(I)
300 FOR C=1 TO T
310 NEXT C
320 Y=USR(0)
330 IF I=20 THEN PR
INT:GOTO 400
350 J=J+1
360 IF J<>5 THEN 40
0
370 FOR J=1 TO U
380 NEXT J
390 J=0
400 NEXT I
410 X=X+1
420 IF X=5 THEN 150
430 GOTO 230

```

K I M A I M S Y M T I M

END FRUSTRATION!

**FROM CASSETTE FAILURES
PERRY PERIPHERALS HAS
THE HDE SOLUTION
OMNIDISK SYSTEMS (5" and 8")
ACCLAIMED HDE SOFTWARE**

- Assembler, Dynamic Debugging Tool.
- Text Output Processor, Comprehensive Memory Test
- Coming Soon—HDE BASIC

PERRY PERIPHERALS S-100 PACKAGE

Adds Omnidisk (5") to
Your KIM/S-100 System

- Construction Manual—No Parts
- FODS & TED Diskette
- \$20. +\$2. postage & handling. (NY residents add 7% tax) (specify for 1 or 2 drive system)

**Place your order with:
PERRY PERIPHERALS
P.O. Box 924
Miller Place, N.Y. 11764
(516) 744-6462**

Your Full-Line HDE Distributor/Exporter



**THE WIZARD AND THE PRINCESS
HI-RES ADVENTURE #2**

Only ON-LINE SYSTEMS could deliver a HI-RES ADVENTURE game on such an epic scale. In this adventure you find you must do battle against an evil wizard in order to save the life of the princess. To find the wizard and his castle you must first cross deserts, oceans, mountains, travel to an island and encounter many strange beasts. You will be forced to learn magic, navigate at sea and dig for treasure. This game should provide months of adventure.

- HUNDREDS OF HI-RES PICTURES (looks great on b/w and color televisions)
- FULL 21-COLOR!! HI-RES GRAPHICS (each room a work of art)
- YOUR GAME MAY BE SAVED FOR LATER CONTINUANCE
- RUNS ON BOTH 48K APPLE II AND APPLE II PLUS
- BY FAR THE MOST AMBITIOUS GRAPHIC GAME EVER WRITTEN FOR THE APPLE!!

Hi-Res Adventure #2 is available now at your local computer store and requires a disk drive. To order directly send \$32.95 to:

On-Line Systems
36575 Mudge Ranch Road
Coarsegold, CA 93614
209-683-6858

VISA, MST CHG, COD, CHECK ACCEPTED

Look for Hi-Res Football coming soon

HDE inc.

HUDSON DIGITAL ELECTRONICS INC.

COMING SOON!

**omni
65**

For 6502 Systems Development
Engineering Support
Word Processing Applications

The latest in a continuing series of advanced hardware and computer program products for KIM, AIM, TIM, SYM.

Progressive Computer Software
405 Corbin Road
York, PA 17403
(717) 845-4954

Lux Associates
20 Sunland Drive
Chico, CA 95926
(916) 343-5033

Johnson computers
Box 523
Medina, Ohio 44256
(216) 725-4560

A-B Computers
115-B E. Stump Road
Montgomeryville, PA 18936
(215) 699-5826

Falk-Baker Associates
382 Franklin Avenue
Nutley, NJ 07110
(201) 881-2430

Laboratory Microcomputer Consultants
P.O. Box 84
East Amherst, NY 14051
(716) 689-7344

Perry Peripherals
P.O. Box 924
Miller Place, NY 11764
(516) 744-6462

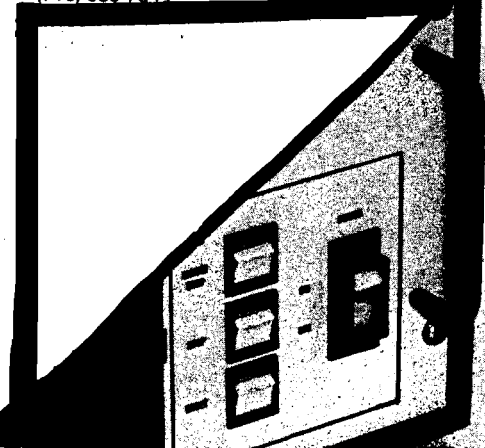

An Apple Flavored Lifesaver

The game of life is made a little easier with this flexible storage program which provides for translation, rotation, and reversal of patterns.

Gregory L. Tibbetts
31417 49th Place S.W.
Federal Way, WA 98003

John Conway's game of Life has one of the largest followings of any computer simulation ever devised. My own interest dates back to my first "cellular excursion" in 1972, on a Hewlett-Packard 2000c machine. Since then I've collected half a dozen versions and have played with several more, all widely different in execution. One serious drawback nearly every version shares, however, is the sheer drudgery of entering from 2 to 200 sets of coordinates each time a simulation is to be run. I've seen several programs with systems to capture coordinates for a given figure—some plain and some incredibly complex. All of these though, are hampered by the fact that Life devotees rarely input the same pattern at exactly the same location and orientation twice, and they usually like to combine figures for interactive effects. One system attempting to circumvent these problems had over 120 individual figures on paper tape, most duplicated up to 8 times for different orientations, and all marked and cataloged. Now that's dedication!

Being basically lazy myself, (after all, I bought a computer to save myself work), I decided that I needed a few simple routines that would let me name and save figures to disk, and then call them back to the screen at virtually any location, at any reasonable orientation, and in combination with any other pattern on file. My goal then, and

the subject of this article, is simply to make Life a little easier. (Pun intended.)

The platform I chose to build my routine on is an excellent machine code/Integer BASIC hybrid program written by Dick Suitor. It appeared most recently in *Best of Micro*, Volume II. Probably the best and most versatile of all the versions I have seen, it has features like variable generation speed, the ability to set random cells alive in a selected field, and the use of contrasting color to show cell development.

My first task was to come up with a method of storing and retrieving the figures. The obvious solution was to save the x,y coordinates in a sequential text file. In order to make the figures completely relocatable however, I needed a way to make the stored coordinates independent of the screen coordinates. The method I chose was to select an arbitrary centerpoint for the figure, prior to input. Then as each coordinate set was typed in, the x, y values of the center point would be subtracted from the x, y values of the point being entered. The result is a set of codified x, y values, positive and negative, which are relative only to the centerpoint, and therefore totally independent of their current screen location. All that's required to relocate the figure then, is to change the centerpoint when calling the figure back from storage.

This method, in conjunction with APPLE's system of screen coordinates, does introduce an irregularity which will become important as we proceed. In normal coordinate systems x values increase as we move to the right, and y values increase as we go up. With the APPLE II, y values increase as we descend on the screen. Further, all screen coordinates are positive, while the codified values may be positive or

negative, since they essentially make up a coordinate grid of their own, with the x (horizontal) and y (vertical) axes intersecting at the chosen centerpoint. Unlike normal grids, therefore, y values will be negative above this x axis and positive below it. It will be necessary to keep this in mind, as it is the codified values we will be manipulating in the coming paragraphs when we determine how to reorient the figures.

This second task, that of finding a way to bring the stored figure back to the screen in a different attitude than originally entered, was somewhat more difficult than simply making it relocatable. However, it quickly became clear that all possible orientations could be achieved by reversing the figure, rotating it, or both.

Rotation is obtained by moving each point clockwise around the center some distance (depending on the degree of rotation), while reversal takes the two dimensional image and flips it over, as one would turn over a playing card. Obviously reversal requires us to know which axis the figure is to be reversed around.

Defining an algorithm to rotate and reverse the figures was an interesting exercise, (actually three exercises and three algorithms). I'm sure that somewhere in the field of coordinate mathematics there exists specific rules for such operations. Being more a tinkerer than a scholar, however, I chose to discover those rules by trial and error. Armed with graph paper and pencil, I defined a center, and x and y axis, and began examining what happened to various sets of coordinates when the points they described were reversed or rotated. The first thing I discovered was that for any single set of coordinates, rotation or reversal involved only two operations: either the unsigned magnitudes of the x and y

values being swapped, or the signs of one or both values being changed. One, or a combination of these two alterations will produce all feasible orientations. I also learned that rotations in other than 90° increments were not feasible for the purposes of the Life game, but the proof of that is left as an exercise for the reader.

The reversal mechanism turned out to be the simplest. A little paper and pencil work showed that no matter which axis was used for reversal, any point remained the same distance from

each axis when reversed. The magnitudes of the x and y values then must remain the same. The signs, however, do not. A reversal around the y axis, for example, sends points from the upper right quadrant (+x, -y) to the upper left quadrant (-x -y), and from lower right (+x, +y) to lower left (-x, +y). Obviously then, reversal on the y axis changes the sign of the x values only. By the same token, an x axis reversal changes the sign of the y values only. Translated into a sequence of program steps this mechanism is implemented in program lines 1070-1110

and 350-400. I also re-solved the further question of whether multiple reversals were desirable, that is, two reversals around one axis, or one around each. I determined they were not, but as a second exercise, for fun, the reader may wish to prove why they were not.

Rotation was a little harder as the cases of 90°, 180°, and 270° rotation all had to be allowed for. Easiest to discover was the 180° process. Just as in the reversal case, a point rotated 180° still remains the same distance from each axis, and therefore, the x and

BASIC Listing

```

0 LOMEM:2500
10 DIM HEX$(30)
20 HEX$="0800<94FB.85FFM NE88AG"
30 FOR I=1 TO LEN(HEX$): POKE 511+I, ASC
(HEX$(I)): NEXT I: POKE 72,0: CALL -144
40 DEL 0,40
50 GOTO 800
60 POKE -16302,0: COLOR=0: FOR K=40 TO 4
7
70 HLIN 0,39 AT K: NEXT K
80 KX= PDL (0)-10: IF KX>240 THEN KX=KX1
: IF KX<0 THEN KX=0
90 K1=KX*6:K2=KX*2:K3=500/(K1+50)+1
100 FOR I=1 TO K3
110 CALL GEN
120 FOR K=1 TO K2: NEXT K
130 CALL MOP
140 FOR K=1 TO SIZE: COLOR=11
150 NEXT I
160 GOTO 80
170 FOR I=1 TO SIZE: COLOR=11
180 X=XCTR+X(I):Y=YCTR+Y(I)
190 IF X<0 OR X>39 OR Y<0 OR Y>39 THEN 1
210
200 PLOT X,Y: NEXT I
210 RETURN
220 FOR I=I1 TO I2: FOR J=J1 TO J2
230 COLOR=11: IF RND (L) THEN COLOR=0
240 PLOT I,J
250 NEXT J: NEXT I
260 GOTO 60
270 FOR I=1 TO SIZE
280 X=Y(I):Y=X(I)
290 IF Y(I) THEN X=X*-1
300 X(I)=X:Y(I)=Y
310 NEXT I: RETURN
320 FOR I=1 TO SIZE
330 X(I)=X(I)*-1:Y(I)=Y(I)*-1
340 NEXT I: RETURN
350 FOR I=1 TO SIZE

```

```

360 IF XAX THEN 380
370 X=X(I):Y=Y(I)*-1: GOTO 390
380 Y=Y(I):X=X(I)*-1
390 X(I)=X:Y(I)=Y: NEXT I
400 RETURN
410 PRINT D$;"OPEN";A$
420 PRINT D$;"READ";A$
430 FOR I= 1 TO 255
440 INPUT X(I),Y(I)
450 IF X(I)=99 OR Y(I)=99 THEN 470
460 NEXT I
470 SIZE=I-1
480 PRINT D$;"CLOSE";A$
490 IF ROT THEN GOSUB 270
500 IF HALF THEN GOSUB 320
510 IF REV THEN GOSUB 350
520 GOSUB 170
530 HALF=0:ROT=0:REV=0:XAX=0:SIZE=0
540 RETURN
550 PRINT D$;"OPEN";A$
560 PRINT D$;"DELETE";A$
570 PRINT D$;"OPEN";A$
580 PRINT D$;"WRITE";A$
590 FOR I=1 TO SIZE
600 PRINT X(I)
610 PRINT Y(I)
620 NEXT I
630 PRINT D$;"CLOSE";A$
640 RETURN
650 FOR I=1 TO 255
660 INPUT X,Y
670 IF X=99 OR Y=99 THEN 720
680 IF X<0 OR X>39 OR Y<0 OR Y>39 THEN 7
00
690 X(I) =X-XCTR:Y(I)=Y-YCTR: GOTO 710
700 PRINT "INPUT X,Y",X,Y
710 NEXT I
720 X(I)=99:Y(I)=99
730 SIZE=I
740 RETURN

```

(continued)

```

750 INPUT "INPUT X,Y",X,Y
760 IF X=99 OR Y=99 THEN 60
770 IF X<0 OR X>39 OR Y<0 OR Y>39 THEN 7
90
780 COLOR=11: PLOT X,Y: GOTO 750
790 PRINT "OUT OF RANGE!": GOTO 750
800 TEXT
810 DIM X(255),Y(255),A$(50),B$(2),D$(1)
820 GEN=2088:MOP=2265:K1=1:K2=1:D$="": R
EM D$=CNTRL D
830 CALL -936:VTAB 5:TAB 9:PRINT"CONWAY'
S GAME OF LIFE":FOR I=1 TO 700:NEXT I
840 GR
850 PRINT "DO YOU WISH TO: 1.PLAY OR 2.C
REATE"
860 INPUT "A NEW PATTERN FILE (1/2).",C1

870 IF C1=2 THEN 1140
880 INPUT "SPEED=PDL(O): SET DEFAULT (0-
255)",KX1
890 PRINT "DO YOU WISH TO: 1.RANDOM PATT
ERN 2. PATTERN"
900 INPUT "SPEED=PDL
900 INPUT "FROM DISK OR 3.STANDARD: (1/2
/3)",C1
910 IF C1=3 THEN 990
920 IF C1=2 THEN 1010
930 INPUT "X DIRECTION LIMITS ",I1,I2
940 IF I1<0 OR I2>39 OR I1>I2 THEN 930
950 INPUT "Y DIRECTION LIMITS ",J1,J2
960 IF J1<0 OR J2>39 OR J1>J2 THEN 950
970 INPUT "ONE IN 'N' CELLS WILL LIVE: E
NTER N",L
980 GOTO 220
990 PRINT "ENTER YOUR PATTERN (X,Y):99,9
9 EXITS"
1000 GOTO 750
1010 INPUT "WHAT FIGURE NAME",A$
1020 INPUT "ENTER CENTER COORD'S (X,Y)",
XCTR,YCTR
1030 INPUT "ENTER ROTATION (0/90/180/270
)",ROT
1040 IF ROT=180 OR ROT=270 THEN HALF=1
1050 IF ROT=90 OR ROT=270 THEN ROT=1
1060 IF ROT<>1 THEN ROT=0
1070 INPUT "ENTER 1.REVERSED OR 2.STANDA
RD (1/2)",REV
1080 IF REV>1 THEN REV=0: IF NOT REV THE
N 1110
1090 INPUT "REVERSE ON 1.X-AXIS OR 2.Y-A
XIS (1/2)",XAX
1100 IF XAX>1 THEN XAX=0
1110 GOSUB 410
1120 INPUT "ANOTHER FIGURE (Y/N)",B$: IF
B$="N" THEN 60

```

```

1130 PRINT "CAUTION:FIGURES MAY OVERWRI
TE!": GOTO 1010
1140 INPUT "ENTER CENTER COORD'S (X,Y)",
XCTR,YCTR
1150 PRINT "ENTER ALL LIVE CELLS (X,Y):
99,99 EXITS"
1160 GOSUB 850
1170 INPUT "ENTER NAME FOR THIS FIGURE",
A$
1180 GOSUB 550
1190 PRINT "TESTING": GOSUB 410
1200 GOTO 60
1210 PRINT "PLOT ABORTED/FIGURE WENT OFF
SCREEN"
1220 PRINT "MOVE CENTERPOINT:X AND Y WHE
N ABORTED"
1230 PRINT "WERE ";X;",";Y: POP: POP
1240 IF I=1 THEN 1020: IE=I-1: COLOR=0:
FOR I=1 TO IE
1250 PLOT X(I)+XCTR,Y(I)+YCTR: NEXT I: G
OTO 1020
1260 REM ADAPTATION BY GREG TIBBETTS OF
RICHARD SUITOR'S PROGRAM IN
1265 REM "BEST OF MICRO" VOLUME II 1979
1270 REM LINES 0-50 PROGRAM SET-UP
1280 REM 60-160 SPEED AND GENERATION
1290 REM 170-210 GENERAL PLOT SUBR.
1300 REM 220-260 RANDOM PLOT SUBR.
1310 REM 270-340 ROTATION SUBR'S.
1320 REM 350-400 REVERSAL SUBR.
1330 REM 410-540 DISK READ SUBR.
1350 REM 750-790 STANDARD INPUT SUBR
1360 REM 800-840 INITIALIZATION
1370 REM 850-920 MODE SELECTION
1380 REM 930-1200 USER INPUT/SELECT
1390 REM 1210-1250 PLOT ABORT SUBR.
10000 END
144542243 LOAD 6146 HLIN 115726885
HIMEM:I RUN P CLR 26884,I INPUT
HIMEM: RUN 43268 LOAD 6149 IF
(8444J RUN ^ HIMEM: RUN 24577
389511692368241661442 MAN HIMEM:
CON ~$ DEL ~= DEL " RUN P:
~$ DEL 61444 MAN HIMEM::~~= DEL
" RUN p CON ~= DEL ~$ DEL 4298
N ,>=2407, COLOR+ DEL 44294
2791334057 RUN >=30982( DEL
(y( DEL 51462:p,51460 LOAD
p,61442,"11042306 SGN 614630983
VTAB DEL (y) DEL 51463:p,51460
LOAD p,61444,"x TAB LOAD 2308
:34820p HIMEM:11084 RUN 34052
SAVE 34048 LOAD 24082456 IF
^ J RUN ^ HIMEM: RUN 2457745351

```

y magnitudes remain the same. Signs however, do not follow the same pattern as during reversal. Since the points in the upper right quadrant (+x, -y) move to the lower left (-x, +y), lower right(+x, +y) to upper left (-x, -y) and vice versa, it becomes clear that both x and y values must change sign. A 180° rotation therefore is accomplished by simply multiplying the two values by -1. This is implemented in lines 1030-1060 and 320-340.

A 90° rotation is not so straightforward. It is best seen by using the example of a clock face with the x axis running through the 9 and 3, and the y axis through the 12 and 6. A 90° rotation of this clock face moves the point at numeral 1 to the position of numeral 4. For the first time, the magnitude of the x and y values have changed. The distance of the point from the y axis in its original position has become the distance from the x axis after rotation

and vice versa. What happens in a 90° rotation then, is that the magnitudes of x and y are simply exchanged. The signs, unfortunately, do not follow such a clearcut pattern. Nevertheless, a pattern does exist. I found it by examining the four quadrants in sequence and noting what happens to their associated x and y signs. Starting at the upper right (+x, -y) and moving to the lower right produces (+x, +y). Another 90° rotation produces (-x, +y), and the final rotation (-x, -y). Study here shows that the sign of x in the original quadrant is the sign y will have in the new quadrant. Since the magnitude of x becomes the magnitude of y also, we can simply give y the signed value of x for every point to be rotated. You can also see that the sign of the new x value is the opposite of the old y value. To get the new x value we must multiply the old signed value of y by -1. These two steps complete the 90° algorithm and it is implemented in

lines 1030-1060 and 270-310. To keep the program as short as possible, 270° rotations were made by using the 90° and 180° subroutines together. This completes the screen output design.

Disk storage is achieved by saving the x and y arrays into a sequential text file; each figure to a separate file. Though this is somewhat wasteful of disk space, I set it up this way to avoid complex file management routines, and to allow for easy renaming and catalog display. The final step was to insert tests in the plot sequence to prevent range errors from crashing the program if a center point was selected that would cause the figure to plot off the screen, and having to restart the program from scratch. The original center-point is not stored with the codified values, and consequently is not available for later examination.

Machine Code Listing

0800 A5 05	LBL I	LDA	\$0005	083D B1 02	LDA	(\$02), Y
0802 85 03		STA	\$0003	083F F0 0F	BEQ	LBL E
0804 A5 04		LDA	\$0004	0841 10 0A	BPL	LBL D
0806 85 02		STA	\$0002	0843 FE 40 09	INC	\$0940, X
0808 18		CLC		0846 FE 70 09	INC	\$0970, X
0809 69 80		ADC	#\$80	0849 29 08	AND	#\$08
080B 85 04		STA	\$0004	084B F0 03	BEQ	LBL E
080D A5 05		LDA	\$0005	084D FE 40 09	LBL D	INC \$0940, X
080F 69 00		ADC	#\$00	0850 B1 04	LBL E	LDA (\$04), Y
0811 C9 08		CMP	#\$08	0852 F0 0F	BEQ	LBL G
0813 D0 0C		BNE	LBL A	0854 10 03	BPL	LBL F
0815 A5 04		LDA	\$0004	0856 FE 70 09	INC	\$0970, X
0817 69 27		ADC	#\$27	0859 29 08	LBL F	AND #\$08
0819 C9 52		CMP	#\$52	085B F0 06	BEQ	LBL G
081B 10 08		BPL	LBL B	085D FE 70 09	INC	\$0970, X
081D 85 04		STA	\$0004	0860 FE 40 09	INC	\$0940, X
081F A9 04		LDA	#\$0004	0863 88	LBL G	DEY
0821 85 05	LBL A	STA	\$0005	0864 CA		DEX
0823 18		CLC		0865 10 CE	BPL	LBL H
0824 60	LBL R	RTS		0867 A0 26	LDY	#\$26
0825 38	LBL B	SEC		0869 18	CLC	
0826 B0 FC		BCS	LBL R	086A AD 67 09	LDA	\$0967
0828 20 CA 08		JSR	LBL S	086D 6D 66 09	ADC	\$0966
082B 20 00 08	LBL X	JSR	LBL I	0870 85 06	STA	\$0006
082E 90 01		BCC	LBL C	0872 AD 97 09	LDA	\$0997
0830 60		RTS		0875 6D 96 09	ADC	\$0996
0831 A0 27	LBL C	LDY	#\$27	0878 85 07	STA	\$0007
0833 98		TYA		087A 18	LBL W	CLC
0834 AA		TAX		087B A5 06	LDA	\$0006
0835 A9 00	LBL H	LDA	#\$00	087D 79 3F 09	ADC	\$093F, Y
0837 99 40 09		STA	\$0940, Y	0880 38	SEC	
083A 99 70 09		STA	\$0970, Y	0881 F9 42 09	SBC	\$0942, Y

The program as it appears in the listing, is set up to run on a 48K APPLE II, using APPLE DOS to store and retrieve the patterns. The instructions for setting up the program, however, are universal with respect to RAM size. I believe that the program could also be converted to use a cassette-based DOS imitator as off-line storage, but that is beyond the scope of this article, (and the ingenuity of the writer as well). The machine code runs resident at \$800 (2048), and the program has been modified to load both sections as a unit, and relocate the machine portion when run. To enter the program, first the machine code must be typed in (from the hex dump below), to occupy the top 261 bytes of RAM. HIMEM: and PP (program pointer) must then be moved down to protect it, the BASIC portion entered, and then HIMEM: moved back to its original value. The BASIC program is then altered to automatically move LOMEM: when run and relocate the code to this pro-

ected area. Readers familiar with these procedures may skip the instructions which follow. For the purposes of these instructions however, it is assumed that the reader is knowledgeable in the process of converting decimal to hexadecimal and back, and is familiar with APPLE's low order, high order byte storage and the method of converting this to whole number values or visa versa.

REM: Entering the Machine Code

1. Boot DOS, type INT and PEEK memory locations 76 and 77 (HIMEM:). Convert these two numbers to their whole number equivalent and that to its hex equivalent. Record all of these numbers.

2. Compute the starting address for the code by subtracting 262 from the whole number value of HIMEM:. Convert this to hex and again record the numbers.

3. Call -151 and enter the 261 bytes of code, starting at the hex address you calculated in step 2. Once entered, type (CNTRL) C and BSAVE LIFE OBJ, A\$XXXX, L261, where XXXX is the hex address from step 2.

4. Now convert the above starting address, minus 1 byte, from a decimal whole number to its low order and high order values. POKE these values as follows: POKE 76, low; POKE 77, high; POKE 202, low; and POKE 203, high. Code is now protected.

REM: Entering the Basic Program

5. Enter line 0 and line 40 as PRINT statements to avoid the SYNTAX ERROR message that would come if LOMEM: and DEL were entered as deferred commands.

6. Enter line 20 exactly as shown with two exceptions. Where the listing shows 94FB, substitute the hex value

(continued)

```

0884 85 06      STA  $0006
0886 C9 03      CMP  #$03
0888 F0 0E      BEQ  LBLK
088A 90 04      BCC  LBLJ
088C C9 04      CMP  #$04
088E F0 0E      BEQ  LBLJ
0890 B1 02      LBLJ LDA  ($02),Y
0892 F0 0A      BEQ  LBLJ
0894 29 85      AND  #$85
0896 50 04      BVC  LBLM
0898 B1 02      LBLK LDA  ($02),Y
089A 09 30      ORA  #$30
089C B1 02      LBLM LDA  ($02),Y
089E 18         LBLJ CLC
089F A5 07      LDA  $0007
08A1 79 6F 09   ADC  $096F,Y
08A4 38         SEC
08A5 F9 72 09   SBC  $0972,Y
08A8 85 07      STA  $0007
08AA C9 03      CMP  #$03
08AC F0 0E      BEQ  LBLP
08AE 90 04      BCC  LBLN
08B0 C9 04      CMP  #$04
08B2 F0 0E      BEQ  LBLT
08B4 B1 04      LBLN LDA  ($04),Y
08B6 F0 0A      BEQ  LBLT
08B8 29 F8      AND  #$F8
08BA 50 04      BVC  LBLV
08BC B1 04      LBLP LDA  ($04),Y
08BE 09 03      ORA  #$03
08C0 91 04      LBLV STA  ($04),Y
08C2 88         LBLT DEY

```

```

08C3 F0 02      BEQ  LBLU
08C5 10 B3      BPL  LBLW
08C7 4C 2B 08   LBLU JMP  LBLX
08CA A9 04      LBLS LDA  #$04
08CC 85 05      STA  $0005
08CE A9 00      LDA  #$00
08D0 85 04      STA  $0004
08D2 8D 68 09   STA  $0968
08D5 8D 88 09   STA  $0988
08D8 60         RTS
08D9 20 CA 08   JSR  LBLS
08DC 20 00 08   LABD JSR  LBLI
08DF 90 01      BCC  LBLY
08E1 60         RTS
08E2 A0 27      LBLY LDY  #$27
08E4 B1 02      LBLU LDA  ($02),Y
08E6 F0 0A      BEQ  LBLZ
08E8 29 7F      AND  #$7F
08EA C9 10      CMP  #$10
08EC 30 02      BMI  LABA
08EE 09 80      ORA  #$80
08F0 91 02      LABA STA  ($02),Y
08F2 B1 04      LBLZ LDA  ($04),Y
08F4 F0 0A      BEQ  LABB
08F6 29 F7      AND  #$F7
08F8 6A         ROR  A
08F9 90 02      BCC  LABC
08FB 09 04      ORA  #$04
08FD 2A         LABC ROL  A
08FE 91 04      LABB STA  ($04),Y
0900 88         DEY
0901 F0 D9      BEQ  LABD
0903 10 DF      BPL  LBL0

```

you calculated in step 2. Where it shows 95FF, substitute the original value of HIMEM: from step 1, minus 1 byte. The format of this string must be exact, as it becomes an APPLE monitor command when the program is run. Be sure the spacing etc., match. Enter all other statements normally.

7. To create the LOMEM: and DEL statements, PEEK locations 202 and 203 (PP) to find the starting address of the BASIC program. Convert these to a single hex value and Call -151. Beginning with that location, examine sequential locations until a byte 62 is found, (this should be within the first 5 bytes). This is the token for the print in line 0. Change this byte to an 11, the LOMEM: token. Keep reading sequentially until a second 62 is found and change this to 09, the DEL token. You must also change the 49 three bytes further on to 0A, changing the PRINT comma to a DEL comma.

8. Now by entering [CNTRL] C and LIST 0, 40; you should see your listing match the one in this article. For safety's sake, save the BASIC program as LIFE B.

REM: Combining the Two

9. Take the original low order and high order byte values for HIMEM: from step 1, and POKE these into locations 76 and 77, respectively. DO NOT RUN THE PROGRAM YET! Now when you SAVE LIFE, the APPLE will obediently save everything from PP to HIMEM:, tucking your machine code safely at the end of your BASIC program.

At this point the program may be run, listed and even changed without difficulty. I would suggest, however, that you keep LIFE OBJ and LIFE B until the combined program is thoroughly use-tested. REM lines at the end of the listing will aid trouble shooting if it becomes necessary. The program is completely automated and self-prompting, therefore I have only a few helpful hints.

First, patterns are best developed on, and input from graph paper numbered along the top and side to match the screen. This gives a backup as well as a hard copy visual image to check the screen output. Second, the centerpoint you select to input the

figure is not automatically set as a live cell. Consequently, it can literally be any point on the screen. You must remember though, that all figures are rotated and reversed around this relative center, and therefore, it should be chosen with care. Third, with really large figures where the choice of center point is critical to keep from plotting the figure off screen, it is helpful to include the center coordinates in the figure name as a guide during recall. Last, due to the finite field limits established by Mr. Sutor's program, known patterns may not behave normally if they contact the edge. Gliders for example, turn to boxes as they hit the edge, rather than continue to move off screen. This is no cause for alarm; simply a fact of Life.

For fun, create a pattern file with the coordinates listed below. Name this figure PULSAR SEED, and use an initial centerpoint of say 19,19. When you run it the results may surprise you. In any case, have fun!

(x,y); (10,8); (9,9); (11,9); (9,10); (11,10); (9,11); (10,11); (11,11); (9,12); (11,12); (9,13); (11,13); (10,14); (9,9,9).

Live long and prosper.

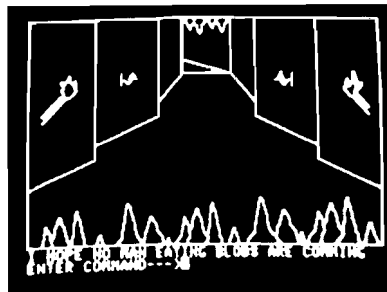
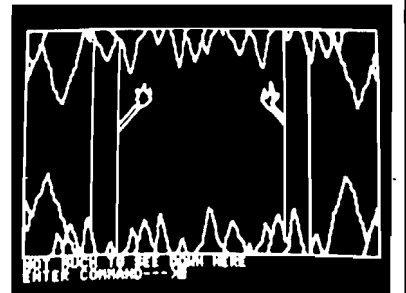
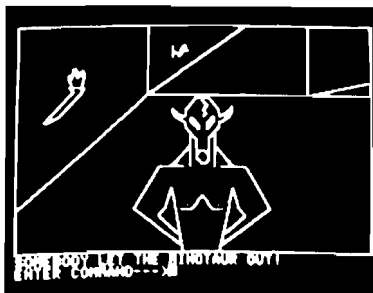
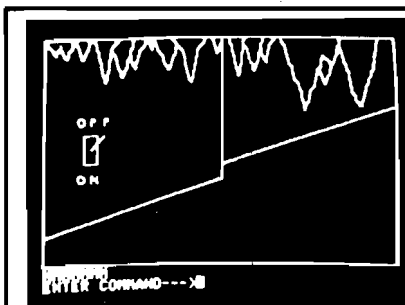

The Tarturian

The Tarturian requires 48K ram, APPLE-Soft ROM, and a disk drive. As you explore the 160 rooms (each done in HI-RES) gathering weapons and treasure that will prepare you for the final battle against the Tarturian, you will encounter the deadly Krolls, battle the Minotaur, discover the Yummy Yakky's secret, make friends with the Tullesweep, avoid Ghouls, kill giant Centipedes, explore the Pillar Tombs, discover secret passages and more.
TARTURIAN on disk \$24.95

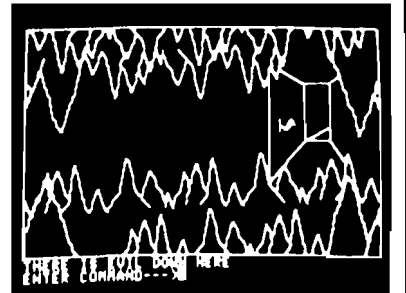
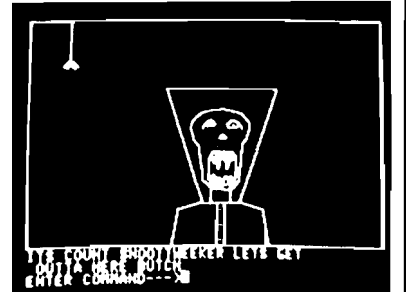

SEE YOUR LOCAL DEALER
OR SEND CHECKS TO
HIGHLANDS COMPUTER SERVICES
14422 Southeast 132nd Street
Renton, Washington 98055
(206) 228-6691

Washington residents add 5.3% sales tax. APPLESOFT and APPLE are registered trademarks of Apple Computers, Inc.

**MICRO-WARE DISTRIBUTING INC.
PRESENTS**

**NEW—THE APPLE CARD — PLASTIC
8½x11 Reference Card for the APPLE
\$3.98.**

NEW DISK SOFTWARE FOR APPLE™:
UNCOPY—A unique way to make APPLE disks uncopyable. Just load in the software that you want protected and init a disk with Uncopy. That's it (not for PASCAL or DOS 3.3 systems). . . . \$29.95
GRAPH FIT—A great hires graphing program that will make 3-d bar charts, pie charts, or line graphs. Just enter the data and the program will do the rest. (48K A-soft). . . . \$25.00

ROAD RALLYE—A stimulating hires auto race game with five spectacular full screen tracks. . . . \$14.95
SUPER SEA WAR—Hires graphics and unique sound add to this computer enhanced version of battleship. 3 levels of play incl. Super Salvo with missiles. . . \$13.65

THE ULTIMATE TRANSFER—Upload or download programs to distant areas over the phone (INTEGER, A-SOFT, MACH. LANG). Needs 48K and DC Hayes Assoc. Micromodem. . . . \$25.00

INSTANT LIBRARY SPECIAL — Buy any 4 of the above 5 and receive a 15% discount!

Z-80 Board for APPLE from Microsoft . . . \$275.00

PRINTERS! PRINTERS! PRINTERS!

EPSON TX-80 w/GRAFTRAX-Full upper & lower case 125 CPS printer that will dump either APPLE hires screen in 2 sizes plus inverse or normal mode. Complete with software for the hires screen dump. Only \$795. APPLE Type Parallels Interface, add \$88.00.

EPSON MX-80-Bi-directional, logic seeking, dot matrix printer with a 9x9 matrix character formation. Characters can be enlarged, condensed, emphasized or double struck and full software control of horizontal & vertical tabs as well as form feed comes standard. Only \$645., APPLE Type parallel interface add \$88.00.

V300 DAISY WHEEL PRINTER-Another fantastic value from Japan. A high quality daisy wheel that uses standard plastic daisies and standard Diablo type ribbon with 136 printable columns. Comes with a full 90 warranty and service available through 417 nationwide WESTERN UNION locations. Only \$1999.00, with APPLE Type Parallel Interface.

Call (201) 839-3478 or (201) 835-7080 for information

Or order from: MICRO-WARE DIST. INC.
439A Route 23
Pompton Plains, NJ
07444

Dealer Pricing on Request!

Presenting the
CJM Microsystem
For the Apple II

The CJM Microsystem for the Apple II

The CJM Microsystem now provides Apple owners with the hardware they need to interface joysticks, sense external inputs, and control other devices such as audio or video recorders. The applications are endless.

Institutional Standards

All metal chassis and heavy duty cables and connectors allow the CJM Microsystem to meet the demands of the educational environment.

A Variety of Applications

The Microsystem can be used for many applications from games to sophisticated computer assisted instruction.

The Microstik can be used for graphics input, menu selection, or any screen oriented function.

The output modules such as the Microbox can run appliances, lamps, motors, relays or other loads from keyboard or program commands.

The input modules can sense temperature, light, or sound to provide external information.

Specialized modules, such as the VTR Controller can sense tape position and drive the VTR forward and reverse utilizing the input and output capabilities interactively.

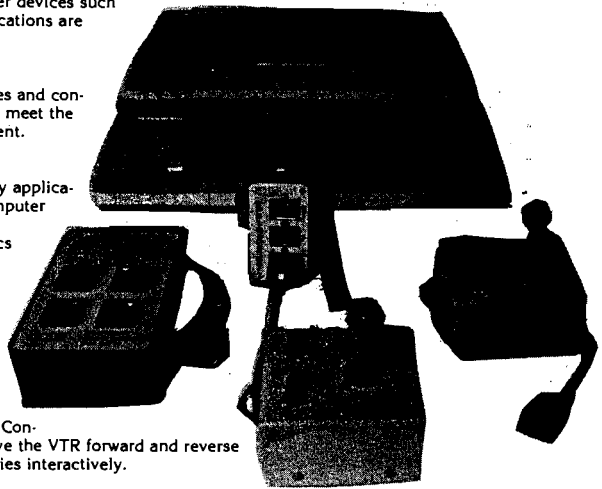

The Graphics Kit Software

This is a disk based program written in Integer Basic and Assembly Language. It uses the Microstiks to simulate the Apple Graphics Pad and adds some extra features, including:

- Draw shapes in 8 modes using Microstiks.
- Draw to both HIRES screens.
- Assemble shapes into tables.
- Select a color from the palette using the Microstik cursor.
- Add text directly to drawings with auto scrolling in either direction.
- Move shapes around the HIRES screens and deposit them at the touch of a button. Press the button again to pick them up off the screen and move them to a new location. Press a key to rotate the shape. Press another to bring up the next shape.
- There are more than 50 distinct drawing commands.
- The Animate Command cuts from screen 1 to screen two and back again.
- The Save Command saves either screen for later use in custom programs as charts or graphs (ideal for CAI applications).

USE YOUR MASTERCARD OR VISA CARDS

APPLEXPANDER+S	\$ 54.95
MICROSTIK	\$ 59.95
AC CONTROL BOX	\$ 89.95
RELAY CONTROL BOX	\$ 89.95
LIGHT PEN	\$ 39.95
GRAPHICS KIT SOFTWARE	\$ 49.95
PDL ADAPTER KIT	\$ 14.95

ORDER TODAY 703-620-2444

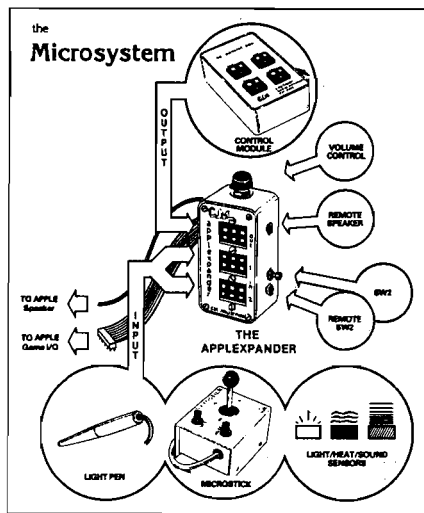

CJM INDUSTRIES, INC.
P.O. Box 2387
Reston, Virginia
22090

The Applexpander

The APPLEXPANDER is the heart of the CJM MICROSYSTEM. The Applexpander plugs into the Apple Game I/O socket. Once the expander is installed there will never be another need to access the game socket. The expander buffers the input and output signals to the Game I/O. Providing the added safety needed to interface to the outside world.

The two input sockets accept a Microstik, Light Pen or an assortment of input devices such as temperature, audio or light sensors.

The output socket will drive the AC Control Box, Relay Modules, LED Arrays and other controllers.

The APPLEXPANDER+S includes an Auxiliary Speaker/Headphone Jack, and Volume Control. The Apple speaker is automatically muted when a speaker is plugged into the remote jack. The volume control adjusts the sound level. When an external speaker (not included) is used, the sound quality of the Apple increases dramatically.

Microstik

The CJM MICROSTIK is a dual axis joystick. It features an all metal rugged chassis, with a heavy duty cable and Jones plug. Each Microstik includes two pushbuttons for interactive control. Additional circuitry reduces the current draw so that two Microstiks can safely be used simultaneously through the game socket. These are high quality units constructed to withstand abuse. Extension cables are available as accessories.



"NIBBLE® IS TERRIFIC" (For Your Apple)

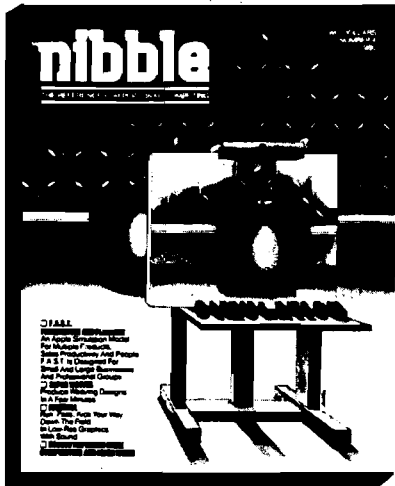

NIBBLE IS: *The Reference for Apple computing!*

NIBBLE IS: One of the Fastest Growing new Magazines in the Personal Computing Field.

NIBBLE IS: Providing Comprehensive, Useful and Instructive Programs for the Home, Small Business, and Entertainment.

NIBBLE IS: A Reference to Graphics, Games, Systems Programming Tips, Product News and Reviews, Hardware Construction Projects, and a host of other features.

NIBBLE IS: A magazine suitable for both the Beginner and the Advanced Programmer.

Each issue of NIBBLE features significant new Programs of Commercial Quality. Here's what some of our Readers say:

- "Certainly the best magazine on the Apple II"
- "Programs remarkably easy to enter"
- "Stimulating and Informative; So much so that this is the first computer magazine I've subscribed to!"
- "Impressed with the quality and content."
- "NIBBLE IS TERRIFIC!"

In coming issues, look for:

- Numeric Keypad Construction Lab Assembly Language Programming Column
- Pascal Programming Column Data Base Programs for Home and Business
- Personal Investment Analysis Electronic Secretary for Time Management
- The GIZMO Business Simulation Game

And many many more!

NIBBLE is focused completely on the Apple Computer systems.

Buy NIBBLE through your local Apple Dealer or subscribe now with the coupon below.

Try a NIBBLE!

No. 4

nibble
Box 325, Lincoln, MA. 01773 (617) 259-9710

I'll try nibble!
Enclosed is my \$15 (for one year).

check **money order**

(Please allow 4 to 6 weeks for delivery of 1st issue)
BACK ISSUES of NIBBLE are available for
\$2.00 + .50 postage and handling.

Name _____

Address _____

City _____

State _____ Zip _____

NOTE:
First Class or Air Mail is required for all APO, FPO and all foreign addresses with the following additional amounts.
— USA, Canada, Mexico, APO, FPO \$7.50
— Central and South America \$9.00
— Europe \$12.00
— Asia and elsewhere \$15.00

© 1980 by MICRO-SPARC., INC., Lincoln, Mass. 01773. All rights reserved.
*Apple II is a registered trademark of Apple Computer Company

MICRO

PET Vet

By Loren Wright

Commodore's recent announcement of several new products has diverted me, for the moment, from my coverage of existing products.

VIC 20 Low-Cost, Full-Feature Computer

The most exciting new product is the VIC 20, billed as "the first full-featured, expandable color computer system selling under \$300." VIC 20 includes 5K of RAM and connects to any TV or monitor. To work with the 6502 in this new computer, MOS Technology has designed a special chip, which includes CRT control, RAM, and ROM. As a result, the VIC features color, sound, programmable function keys, high resolution graphics (176 x 184), and support for joysticks, paddles, and light pens. Other features include a standard-size typewriter keyboard, 23-line by 22-column display, graphics characters, and an expanded PET BASIC. Memory is expandable to 32K RAM, and provision is made for plug-in ROM cartridges, which will include a wide variety of games, educational and special-application programs. Commodore plans several peripherals for use with the VIC's serial bus (IEEE-488 is not supported) and for the RS-232 port. One of these, the CBM 2031 disk drive, has already been announced. Other peripherals planned are a tape cassette unit, a printer, and add-on accessories.

"User-friendly" is a theme Commodore applies to the VIC 20, and this goes especially for the documentation, as described in the company's press release:

Commodore will provide excellent documentation for first-time users as well as software writers and computer entrepreneurs, in the form of books and manuals—some of which will be written and marketed by outside publishers, with Commodore's support.

The VIC, already on sale in Japan, has met with even greater response than expected. Production in the U.S. has begun already and display units

will be distributed to dealers in January 1981. General availability should follow shortly thereafter. If you had planned your Christmas dollars for another computer, you should strongly consider waiting for the VIC 20.

CBM 2031 Single Floppy Disk Drive

The CBM 2031 will be a low-priced single-drive floppy disk unit, available in both IEEE-4888 and serial versions. Serial-written disks will be readable on parallel disk drives, and *vice versa*, barring incompatibility in the programs themselves (such as trying color commands on a PET). Additional 2031's or dual-drive units may be added later, as needs and budgets dictate. The cost of the 2031 will be under \$600.

CBM 8061/8062 "IBM-compatible" 8-inch Floppy Disk Drive

The CBM 8061 and 8062 are new "IBM-compatible" 8-inch floppy disk-drive units. ("IBM-compatible" means that the IBM 3740 data exchange format is followed.) The 8061 can handle 1.6 megabytes, using a single side of each diskette, and the 8062 can write 3.2 megabytes, using both sides of the two diskettes.

Programs written on a PET or CBM can be transferred easily to a larger computer system, and, of course, the opposite is true. At the same time, compatibility with Commodore's smaller disk-drive products is maintained. Translation through the CPU is easily accomplished with the appropriate programs. These will be available in early 1981.

80 x 50 PET Graphics

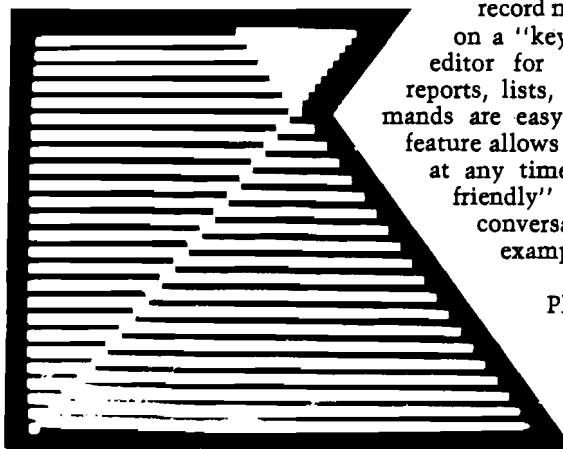

(See Davis article, this issue, p. 15)

CBM 8096 96K Business Computer

The CBM 8096, containing 96K of user RAM, has been added to the business line. This is essentially an 8032 with an added 64K RAM. Large, sophisticated programs will be usable, including the interesting possibilities of running FORTRAN and COBOL programs. CBM 8096 is available now.

Wordcraft 80 Word Processor for CBM 8032

Two new business software packages—OZZ and Wordcraft 80—were announced. Both were demonstrated in prototype versions at the National Small Computer Show in New York, which I attended on November 1. Wordcraft 80 is a powerful word-processor program designed specifically for the CBM 8032. Combined with the 8032, a disk-drive unit, and a letter-quality printer, the cost of a Wordcraft 80 system is about \$5000. This compares very favorably with some dedicated systems which cost a lot more. Some of its features include merging from disk files for form letters, automatic centering and right margin justification, transfer of text from one page to another, character string search and replace, and automatic underlining and boldening of text. Wordcraft 80 is available now.

OZZ—The Information Wizard

"OZZ—The Information Wizard" was also designed specifically for the 8032. It is a very flexible machine code program that allows the user to set up and format information on the screen. Boxes are labeled, and then may be combined in user-specified calculations to update the contents of other boxes. These calculations may also be easily changed. Access to disk files is by record number, index title, or by search on a "key word." There is a document editor for printed information such as reports, lists, and mailing labels. The commands are easy to remember, but a "help" feature allows the user to refresh his memory at any time. Commodore applies "user-friendly" to OZZ's documentation. It is conversationally written, with many examples. OZZ is available now.

Please address correspondence to:
MICRO
Pet Vet
P.O. Box 6502
Chelmsford, MA 01824

APPLE & PET

MAE

The Most Powerful Disk-Based
Macro Assembler/Text Editor
Available at ANY Price

Now includes the Simplified Text Processor (STP)

For 32K PET, disk
3.0 or 4.0 ROMS or — OR — 48K APPLE II
8032 (specify) or APPLE II +
and DISK II

MAE FEATURES

- Control Files for Assembling Multiple named source files from disk
- Sorted Symbol table — Up to 31 chars./label
- 27 Commands, 26 Pseudo-ops, 39 Error Codes
- Macros, Conditional Assembly, and a new feature we developed called Interactive Assembly
- Relocatable Object Code
- String search and replace, move, copy, automatic line numbering, etc.

STP FEATURES

- 17 text processing macros
- Right and left justification
- Variable page lengths and widths
- Document size limited only by disk capacity
- Software lower case provision for APPLE II without lower case modification

ALSO INCLUDED

- Relocating Loader
- Sweet 16 macro library for APPLE and PET
- Machine Language macro library
- Sample files for Assembly and text processing
- Separate manuals for both APPLE and PET

PRICE

- MAE, STP, Relocating Loader, Library files, 50 page manual, diskette — \$169.95

SEND FOR FREE DETAILED SPEC SHEET

EASTERN HOUSE SOFTWARE
3239 LINDA DRIVE
WINSTON-SALEM, N. C. 27106

(919) 924-2889

(919) 748-8446

PET and APPLE II Users

PASCAL

ABACUS Software makes available its version of TINY PASCAL for the users of two of the most popular personal computers.

TINY PASCAL is a subset of the standard PASCAL as defined by Jensen and Wirth. It includes the structured programming features: IF-THEN-ELSE, REPEAT-UNTIL, FOR TO/DOWN TO-DO, WHILE-DO, CASE-OF-ELSE, FUNC and PROC. Now you can learn the language that is slated to become the successor to BASIC.

TINY PASCAL is a complete package that allows you to create, compile and execute programs written in the PASCAL language. You can save source and object code on diskette or cassette (PET version only). Comprehensive user's manual included. The manual can be examined for \$10 (refundable with software order).

REQUIREMENTS

PET 16K/32K New ROMS cassette	\$40
PET 16K/32K New ROMS diskette	\$35
Apple II 32K Applesoft ROM w/DOS	\$35
Apple II 48K Applesoft RAM w/DOS	\$35
TINY PASCAL User's Manual	\$10
6502 Interpreter Listing	\$20



FREE postage in U.S. and CANADA
All orders prepaid or COD

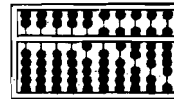

ABACUS SOFTWARE

P. O. Box 7211

Grand Rapids, Michigan 49510

1,000,000 Bytes

PET/BETA-1

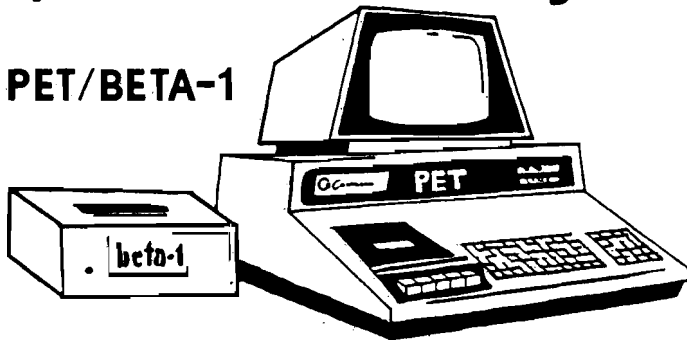

THE FLOPPY DISK ALTERNATIVE

FLEXIBLE DATA MANAGEMENT . . . MICRO-PROCESSOR
CONTROLLED BETA-1 UNIVERSAL TAPE DRIVE BY MECA* . . .
PERIPHERAL DEVICE WITH COMPLETE SOFTWARE SUPPORT

The PET/BETA-1 digital tape system provides all the features of a disk, with powerful data handling capabilities. Your PET/CBM handles big jobs with a data capacity of one megabyte per drive, fast seek times, and 1k per second data transfer rates. Put your records on line with PET/BETA-1.

PET/BETA-1 SYSTEM

Single density (512k/drive)	\$555.00
Double density (1 meg/drive)	\$700.00
MANUAL	\$10.00

F S S

software for small computers

1983 Rio Grande
Austin, Texas
78705

1-512-477-2207

P.O. Box 8483
Austin, Texas
78712

PET/CBM Software

INTELLIGENT DATA COMMUNICATIONS

Turn your PET into an intelligent terminal with one of our terminal packages. These are complete assembled hardware and software packages. All include line editing/resend, repeat key, shift lock, output to CBM printer, and more... Delivered on PET cassette with manuals. Inquire for modem prices.

FORTH

Interactive high level compiler and operating system 5-10 times faster than PET BASIC. High level block structured language. A Fig Forth. See August 1980 BYTE-featuring FORTH.

With interactive assembler providing high level logic constructs and macro capability.

Terminal

PETTERM I	All features above.....	\$75.00
PETTERM II	All features of I, plus local text editor with down-loading capability..	\$90.00
PETTERM III	All features of II, plus 80/132 column scrolling window for viewing formatted outputs wider than 40 columns.	\$100.00

Games

Fast paced multiplayer games with single player mode. Delivered on PET cassette.
Each.....\$15.00

NUCLEAR WAR	Nuclear confrontation on a global scale. Many scenarios.
GALAXY	Pillage a 3-D galaxy collecting loot from captive worlds.
STOCK MARKET	Rags to riches game of buy and sell with computer stocks.
ENCRYPT	Solve coded messages in a race against time.
ALIEN	Protect the federation. Real time 3-D navigation.

MICRO

Classified

OSI Tee-Shirts

Black Mens shirt with blue on white OSI Logo. We're the only source! Send size and \$7.50 plus \$.75 postage per shirt to: COMPUTER BUSINESS SERVICE, P.O. Box 20384, San Jose, CA 95120.

PROGRAMMER FATIGUE?

SYM-BUG/MONEX adds 15 commands to SYM's repertoire including an interactive trace/debug. Cassette at \$0200 or \$3800: \$19.95. EPROM (2716-5V) at \$F000-\$F7FF: \$39.95. Commented source listing: \$9.95. RAE-1(1/2) FORMAT CASSETTE: \$35 (requires 8K). Custom assembly add \$2.00. Foreign add \$2.00. SASE for more information. Jeff Holtzman, 6820 Delmar-203, St. Louis, MO 63130.

C1P EXTENDED MONITOR

2K EPROM has 14 cursor control/editing functions, improved keyboard decoding. Machine lang. save, load, display, modify, move, breakpoint processing and much more. For 24, 32, 64 char/line. \$39.95 plus \$1.00 shipping. \$1.00 for complete info. BUSTEK, P.O. BOX A, St. Charles, MO 63301.

Agenda - Memory Aid

16K IB program with options: New tasks, Read and Write database using tape or diskette, Agenda listing, Enter or Log tasks done, Daily or Total score, Correct data, and Sort tasks. Tape is \$7.50, diskette \$10.00. Full documentation included. Microspan Software, 709 Caldwell St., Yoakum, TX 77995.

SYM-1 Books by Robert Peck

Monitor Theory Manual \$8.00. Hardware Theory Manual \$6.00. SYM/KIM Appendix to First Book of KIM \$4.25. Send SASE for details. Datapath, P.O. Box 2231, Sunnyvale, CA 94087.

Integer Pascal System

for the APPLE II. Compiler, interpreter and translator included for \$65.00. Produces 6502 code programs for high speed. 48K and Disk required. Send for free information. M & M Software, 380 N. Armando 2-19, Anaheim, CA 92806.

—MICRO Classifieds—

A classified ad in MICRO will bring your products/services to the attention of thousands of readers. These ads are placed in clusters throughout the magazine. Each classified ad costs only \$10.00 per insertion. Please limit these to no more than 40 words. Title line, name and address are not considered in the count. Ads must be pre-paid and received before the end of the month preceding the month of publication. Ads received later than the required date will be placed in the next issue. Send to:

MICRO—Classifieds
P.O. Box 6502
Chelmsford, MA 01824

APPLE II PROGRAM FIRST TIME EVER ** VU #3 **

VU #3 will allow the User to enter data into VISICALC* from any program by inserting data into a file. Then the program places the file into VISICALC* (well documented in the instr.)

VU #3 will also transfer data generated from VISICALC* into any of the User's programs.

*VISICALC is a Trademark of
Personal Software, Inc.

\$69.95 plus \$4.95 p. & h.

PROGRESSIVE SOFTWARE

P.O. Box 273
Ply. Mtg., PA 19462

PA Residents Add 6% Sales Tax

Decision Systems

Decision Systems
P.O. Box 13006
Denton, TX 76203

INDEXED FILES

\$60

ISAM-DS is an integrated set of routines for the creation and manipulation of indexed files. ISAM-DS provides capabilities comparable to those on large mainframes. You can rapidly retrieve records by key value or partial key value (retrieves any record in a 200 record file, 60 char/record, in less than 3 seconds compared to a maximum of 38 seconds for a DOS sequential file). Files never have to be reorganized. Duplicate key values may be used. Records may also be retrieved in sequence. ISAM-DS routines are easily integrated into Applesoft programs — they use less than 3K RAM plus an index table.

Requires: Disk, Applesoft

STRUCTURED BASIC

\$35

PBASIC-DS is a sophisticated preprocessor for structured BASIC. Now you can gain the power of PASCAL-like logic structures at a fraction of the cost. Use all regular BASIC statements plus 14 commands and 11 new statements/structures (WHILE, UNTIL, CASE, etc.). PBASIC-DS can be used to develop INTEGER or APPLESOFT programs. It is a great way to learn and use structured logic concepts.

Requires: Disk, Applesoft (48K ROM)

DATA ENTRY

\$25

FORM-DS is a system of programs and routines that assist in the entry, editing and display of data. Describe screen formats by simply typing them on the screen. Automatic range tests for input data. Display edited numeric values with commas inserted, etc. Dump the screen contents to a printer. Routines are easily incorporated into Applesoft programs. Documentation included.

Requires: Disk, Applesoft (32K ROM)

(Texas residents add 5% tax)
(Add \$4.00 for Foreign Mail)

*Apple II is a registered trademark of the Apple Computer Co.

NIKROM TECHNICAL PRODUCTS PRESENTS A DIAGNOSTIC PACKAGE FOR THE APPLE II AND APPLE II+ COMPUTER.

"THE BRAIN SURGEON"

All major computer systems are checked for functional hardware analysis on a regular basis for logical as well as some practical reasons. Finding what is exactly wrong can account for most of the money consuming down-time.

Apple Computer Co. has provided you with the best equipment available to date. The Diagnostic's Package was designed to check every major area of your computer, detect errors, and report any malfunctions. **The Brain Surgeon** will put your system through exhaustive, thorough procedures, testing and reporting all findings.

The Tests Include:

- MOTHERBOARD ROM TEST FOR BOTH APPLE II AND APPLE II+
- APPLESOFT CARD TEST • INTEGER CARD TEST • MEMORY RAM TEST
- DISK DRIVE ANALYSIS • MONITOR ALIGNMENT
- DC HAYES MICROMODEM II TEST

System Diagnosis is an invaluable aid to your program library even if your system is working fine. Hours have been wasted trying to track down a "program bug" when actually hardware could be the blame!

The Brain Surgeon allows you to be confident of your system. This can be critical when file handling, sorts or backups are involved. You *must* depend on your computer during all these critical times. Running **The Brain Surgeon** prior to these important functions helps to insure that your system is operating at peak performance.

The Brain Surgeon is easy to use and supplied on diskette with complete documentation.

PRICE: \$39.95
REQUIRES: 32 or 48K
APPLESOFT in ROM, 1 Disk Drive
DOS 3.2 or 3.3

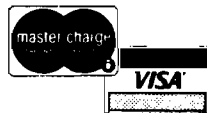

Nikrom Technical Products

25 PROSPECT STREET • LEOMINSTER, MA 01453

APPLE is Registered
Trademark of Apple Computer Co.
MICROMODEM II is Registered
Trademark of D.C. HAYES

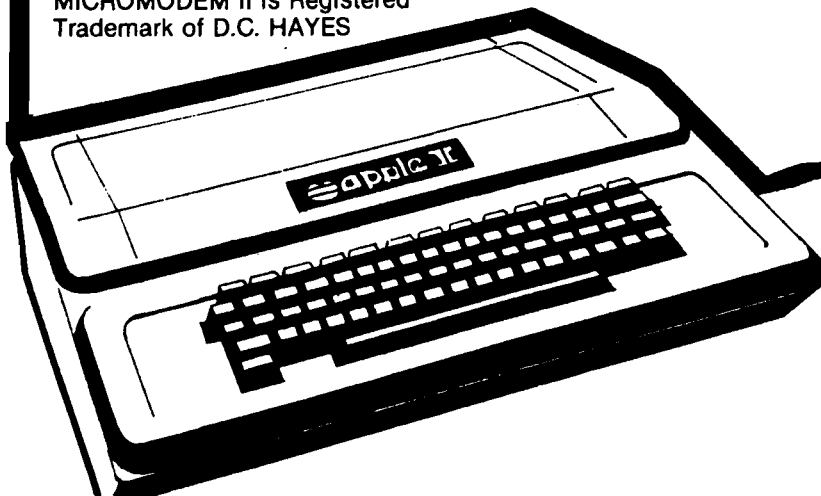

Creating An Applesoft BASIC Subroutine Library

There's more than one way to run a BASIC program on your APPLE with DOS. Using EXEC files offers increased flexibility over the RUN command. In this article the author uses the power of the EXEC command to link Applesoft programs from a common library of disk-resident subroutines.

N.R. McBurney
2561 Stockbridge Rd.
Marietta, GA 30062

DISK FULL! Well, of course it was full. I had over a dozen lengthy programs stored on it. In each of those programs over fifty percent of the code was identical BASIC routines. Besides the

problem of disk space, maintaining identical copies of software is almost impossible. After any given period of time identical software will differ. This is a corollary to somebody's DP axiom that "identical data bases aren't".

The first problem is to find a way to append the subroutines to the main programs. To do this, we need to know how BASIC programs are stored in RAM. With ROM BASIC, the user program usually starts in location 2049 (\$801). RAM [cassette] BASIC normally starts at 12289 (\$3001). All of the examples in this article assume and were executed with the ROM version of Applesoft BASIC. This start address is stored in locations 103-104 (\$67-\$68). Similarly, the end of the program is pointed to by locations 175-176 (\$AF-\$B0). This is shown graphically in figure 1, step 1. If we change the start of the program pointer to the end of our

program (figure 1, step 2), then load our subroutines (figure 1, step 3) we need only change our start of program pointer back to its original value (figure 1, step 4), to to have successfully merged our two programs. To do this manually, first:

LOAD MAIN PROGRAM

where MAIN PROGRAM is the name of the file containing your BASIC program minus your subroutines. Next type:

I = PEEK(176) * 256 + PEEK(175) - 2

As we stated before, decimal locations 176-175 (\$AF-\$B0) contain the address of the end of the program currently in RAM. Now type:

POKE 104,INT(I/256)
POKE 103,I-INT(I/256)*256

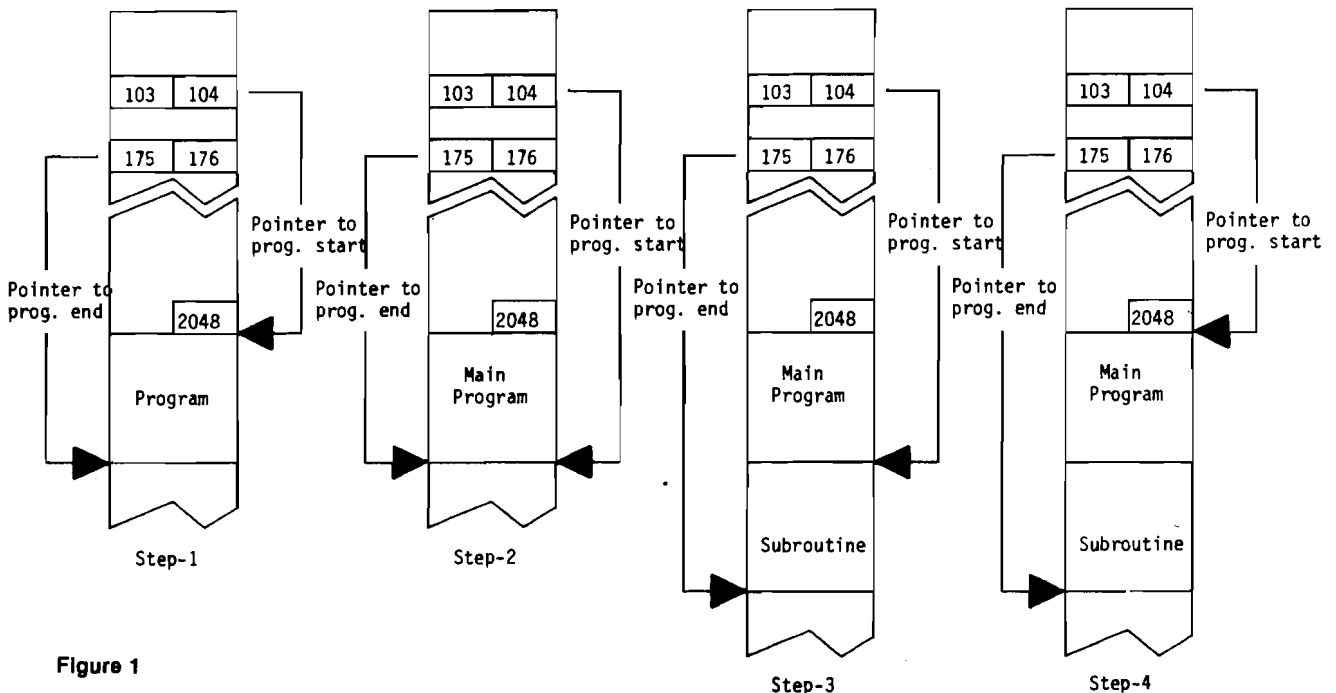

Figure 1

Decimal locations 103-104 contain the address of the start of the BASIC program. This is normally 2049 (\$801). The above two statements changed the starting address to now point to the end of our main program. Now we type:

```
NEW
LOAD SUBROUTINES
```

where SUBROUTINES is the name of the file containing the routines required by MAIN PROGRAM. SUBROUTINES has now been loaded behind our first program, leaving our original program still intact in RAM. Finally we type in:

```
POKE 103,1
POKE 104,8
```

These two statements changed the pointer to the start of our program back to its original value (2049 decimal, \$801 hex). Assuming that you haven't made any typing errors, if you now type LIST, you will see that you have successfully appended SUBROUTINES to MAIN PROGRAM.

When we have many programs using the same set of subroutines, this process will save core, but it doesn't result in user-oriented software. There's an easier way! The process can be handled with an EXEC file. APPLE DOS EXEC files allow you to store on a text file what you would normally type in at the keyboard. When you EXEC a file, APPLE DOS processes each line exactly as if it had been typed in at the keyboard. This is an extremely powerful tool. This article explores just one use of that power.

Program listing 1 contains code for a generalized EXEC file writer. It requests an EXEC file name, creates or replaces the file and then writes the quoted lines contained in the program's DATA statements onto the named text file. Any apostrophes (') in the DATA statements are converted to quotes (") before writing to the EXEC file. This feature allows us to write PRINT statements to the EXEC file.

If we run the program shown in listing 1, we produce the EXEC file shown in listing 2. Let's look at a simple example of how to use this EXEC file.

For this example, the file called MAIN PROGRAM [our main program] contains the instructions shown in listing 5. Our subroutine file, SUBROUTINES, contains the instructions shown in listing 6. If we type

EXEC MERGE (the name of the EXEC file in listing 2), we would have the following (user input is underlined):

```
]LOAD MAIN PROGRAM
]EXEC MERGE
]
]
]SUBROUTINES LOADED...
]LIST
      (listing appears)
```

What we've just done is create a library routine loader! While this approach has proven adequate for development work, expecting an end user to remember which main program must be used with which EXEC file is expecting a human being to adapt to the requirements of the computer. Unfortunately, this kind of design mentality has been prevalent in the industry and is responsible for much of the public's distaste for computers. A more professional approach is possible.

There are several ways that the linking operation can be made invisible to the user and more production oriented for the developer. Our previous example could have included both the LOAD MAIN PROGRAM and RUN statements. Listing 3 contains an EXEC file with these changes. Using this EXEC file results in the following:

```
]EXEC TITLE DEMO
]
]      (Apple HOME's)
]      FIRST LINE OF TITLE
]      SECOND LINE
```

The problem with this approach is that it requires a separate EXEC file to execute each program. Every disk file requires a minimum of one sector of overhead plus one sector minimum for the program. This approach is not completely compatible with our original goal of minimizing storage requirements. A better approach, in my opinion, is to write a menu program that [invisible to the user] determines the names of the programs to be linked together by our EXEC file. These file names are stored by the menu program in RAM, and then the linking EXEC file is EXECed under program control. The EXEC file retrieves the names from RAM and runs the combined program. Listing 7 contains a sample menu program that illustrates this concept.

In our menu, program lines 1000-1190 display the menu shown in figure 2. Lines 1200-1340 request the user to enter the number of his request (the line ENTER YOUR REQUEST NUMBER... is "crawled" along the bottom of the screen). Line 1290 checks to see if a key has been

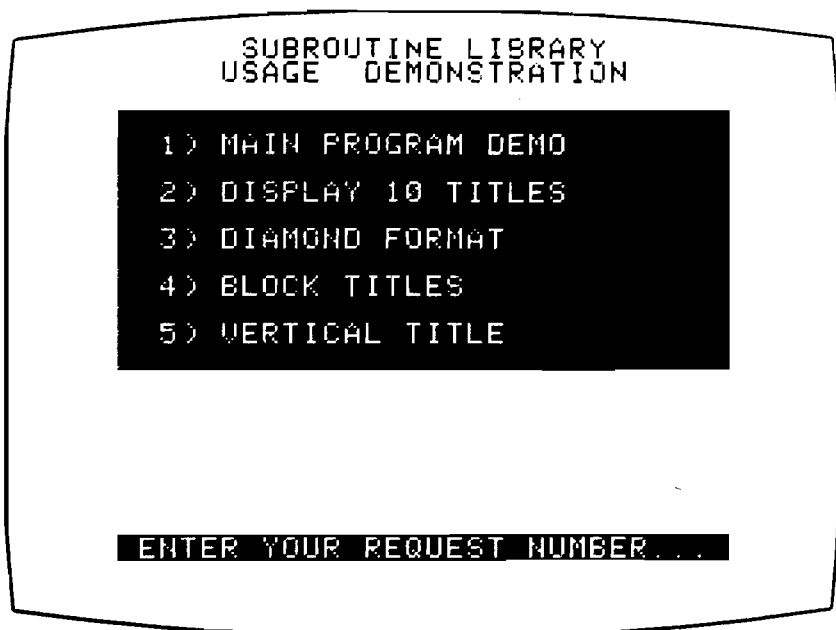

Figure 2

depressed, and if it has, line 1340 converts it from ASCII code to a digit. Lines 1350-1450 map the request number into a main program name. Since all of the programs require the same subroutine file, the name of that file is set in line 1530. The loop in lines 1550-1580 POKES the two file names into locations 768-829 (\$330-\$333D). Locations 768-829 are generally

available to the user. Finally, line 1610 EXECs the file MASTER MERGE shown in listing 4 and runs the desired combined programs.

I have been using various permutations of the techniques described in this article for several months and have found them to be extremely workable. The only obvious restriction is that

subroutine line numbers must be larger than the last line of the main program. In practice, I've limited my main programs to lines 1-29999 and my subroutines to lines 30000-65000. The small amount of discipline that this restriction imposes is more than offset by the twin benefits of more effective disk space utilization and easier software maintenance.

```

1020 REM QUOTES IN THE DATA STATEMENTS + CHR$(34)
1021 REM ARE USED ONLY AS DELIMITERS AND. 1220 NEXT
1030 REM WILL NOT APPEAR ON THE EXEC 1230 PRINT A$
1031 REM FILE. APOSTROPHES IN THE DATA 1240 GOTO 1170
1040 REM STATEMENTS WILL APPEAR ASQUO- 1241 REM
1050 REM TATION MARKS IN THE EXEC FILE. 1245 REM CHECK FOR CORRECT ERROR CODE
1060 REM 1246 REM (#42=OUT OF DATA)
1070 D$ = CHR$(4) 1247 REM
1080 HOME: PRINT CHR$(7) 1250 IF PEEK(222) = 42 THEN GOTO 1255
1090 INPUT "NAME FOR EXEC FILE?";FILE$ 1251 PRINT "ERROR #"; PEEK(222)
1100 HOME 1252 PRINT "IN LINE #" + PEEK(218) + PEE
1110 PRINT D$;"MON O" K(219) * 2556
1120 PRINT D$;"OPEN";FILE$ 1253 STOP
1130 PRINT D$;"DELETE";FILE$ 1255 POKE 216,0
1140 PRINT D$;"OPEN";FILE$ 1259 PRINT D$;"NOMON O"
1150 PRINT D$;"WRITE";FILE$ 1260 PRINT D$;"CLOSE";FILE$
1160 ONERR GOTO 1250 1270 REM
1162 REM READ IN LINE AND REPLACE 1280 REM BEGIN DATA STATEMENTS DEFINING
1163 REM APOSTROPHES WITH QUOTES 1290 REM TEXT TO BE PLACED IN EXEC FILE
1164 REM 1300 REM
1170 READ S$ 1310 DATA "I=PEEK(176)*256+PEEK(175)-2:PO
1180 A$ = "" KE104,INT(I/256):POKE103,I-INT(I/256)*
1190 FOR I = 1 TO LEN(S$) 256."
1200 IF MID$(S$,I,1) <> "" THEN A$ = A$ 1320 DATA "LOAD SUBROUTINES"
+ MID$(S$,I,1) 1330 DATA "POKE 103,1:POKE 104,8:PRINT '
1210 IF MID$(S$,I,1) = "" THEN A$ = A$ SUBROUTINES LOADED...';CHR$(7)"

```

Listing 1: Generalized EXEC File Writer Program

```

LOAD MAIN PROGRAM
HOME:I=PEEK(176)*256+PEEK(175)-2:POKE 10
4,INT(I/256):POKE 103,I-INT(I/256)*256
LOAD SUBROUTINES
HOME:POKE 103,1:POKE 104,8:PRINT "SUBROU
TINES LOADED...";CHR$(7)
RUN

```

Listing 2: EXEC File MERGE

```

MAINS="":FORI=1TO30:MAINS=MAINS+CHR$(PEE
K(767+I)):NEXT:PRINT CHR$(4);"LOAD ";MAI
N$
I=PEEK(176)*256+PEEK(175)-2:POKE 104,INT
(I/256):POKE 103,I-INT(I/256)*256
SUBR$="":FORI=1TO30:SUBR$=SUBR$+CHR$(PEE
K(798+I)):NEXT:PRINT CHR$(4);"LOAD ";SUB
R$
POKE 103,I:POKE 104,8
RUN

```

Listing 4: EXEC File MASTER MERGE

```

LOAD MAIN PROGRAM
HOME:I=PEEK(176)*256+PEEK(175)-2:POKE 10
4,INT(I/256):POKE 103,I-INT(I/256)*256
LOAD SUBROUTINES
HOME:POKE 103,I:POKE 104,8
RUN

```

Listing 3: EXEC File TITLE DEMO

(continued)

```

100 REM
110 REM DEMONSTRATION MAIN PROGRAM
120 REM
130 HOME
140 TITLES$ = "FIRST LINE OF TITLE"
150 GOSUB 10000
160 TITLES$ = "SECOND LINE"
170 GOSUB 10000
180 END

```

Listing 5: MAIN Program

```

10000 REM
10010 REM DEMONSTRATION SUBROUTINE TO
10020 REM PRINT A CENTERED TITLE LINE
10030 REM
10040 L = LEN (TITLES$)
10050 PRINT TAB (20 - L / 2);TITLES$
10060 RETURN

```

Listing 6: SUBROUTINE File

```

1010 REM MENU DEMONSTRATION PROGRAM
1020 REM
1030 HOME
1040 REM
1050 REM DISPLAY THE MENU
1060 REM
1070 PRINT TAB( 10);"SUBROUTINE LIBRARY"
1080 PRINT TAB( 9);"USAGE DEMONSTRATION"
1090 INVERSE
1100 FOR I = 4 TO 14
1110 HTAB 5
1120 VTAB I
1130 PRINT TAB( 35)
1140 NEXT
1150 VTAB 5: HTAB 7: PRINT "1) MAIN PROG
RAM DEMO"
1160 VTAB 7: HTAB 7: PRINT "2) DISPLAY 1
0 TITLES"
1170 VTAB 9: HTAB 7: PRINT "3) DIAMOND F
ORMAT"
1180 VTAB 11: HTAB 7: PRINT "4) BLOCK TI
TLES"
1190 VTAB 13: HTAB 7: PRINT "5) VERTICAL
TITLE"
1200 REM
1210 REM REQUEST AND WAIT FOR INPUT
1220 REM
1230 AS+" ENTER YOUR REQUEST NUMBER..."
1240 VTAB 22
1250 HTAB 5
1260 AS + MID$ (AS,2) + LEFT$ (AS,1)
1270 PRINT AS
1280 FOR I = 1 TO 8
1290 X = PEEK ( - 16384)
1300 IF X > 128 THEN 1330
1310 NEXT

```

Listing 7: MENU Program

```

1320 GOTO 1240
1330 POKE - 16368,0
1340 X = X - 176
1350 REM
1360 REM DETERMINE WHICH PROGRAM TO
1370 REM APPEND SUBROUTINES TO AND
1380 REM THEN RUN THAT PROGRAM VIA
1385 REM THE EXEC FILE
1390 REM
1400 IF X = 1 THEN MAIN$="MAIN PROGRAM"
"
1410 IF X = 2 THEN MAIN$ = "TEN TITLES"
1420 IF X = 3 THEN MAIN$ = "DIAMOND"
1430 IF X = 4 THEN MAIN$="BLOCK TITLES"
1440 IF X = 5 THEN MAIN$ = "VERTICAL TIT
LE"
1450 IF MAIN$ = "" THEN PRINT CHR$(7):
GOTO 1240
1460 NORMAL
1470 REM
1480 REM POKE NAME OF MAIN PROGRAM INTO
1485 REM LOCATIONS $300-$31E AND NAME
1490 REM OF SUBROUTINE FILE INTO
1500 REM LOCATIONS $31F-$33D
1510 REM
1520 K1 = 767:K2 = 798
1530 SUBR$ = "SUBROUTINES"
1540 MAIN$ = LEFT$ (MAIN$ + "
",30)
1550 FOR I = 1 TO 30
1560 POKE K1 + I, ASC (MID$(MAIN$,I,1))
1570 POKE K2 + I, ASC (MID$(SUBR$,I,1))
1580 NEXT
1590 HOME
1600 PRINT CHR$(7)
1610 PRINT CHR$ (4);"EXEC MASTER MERGE"

```

MICRO

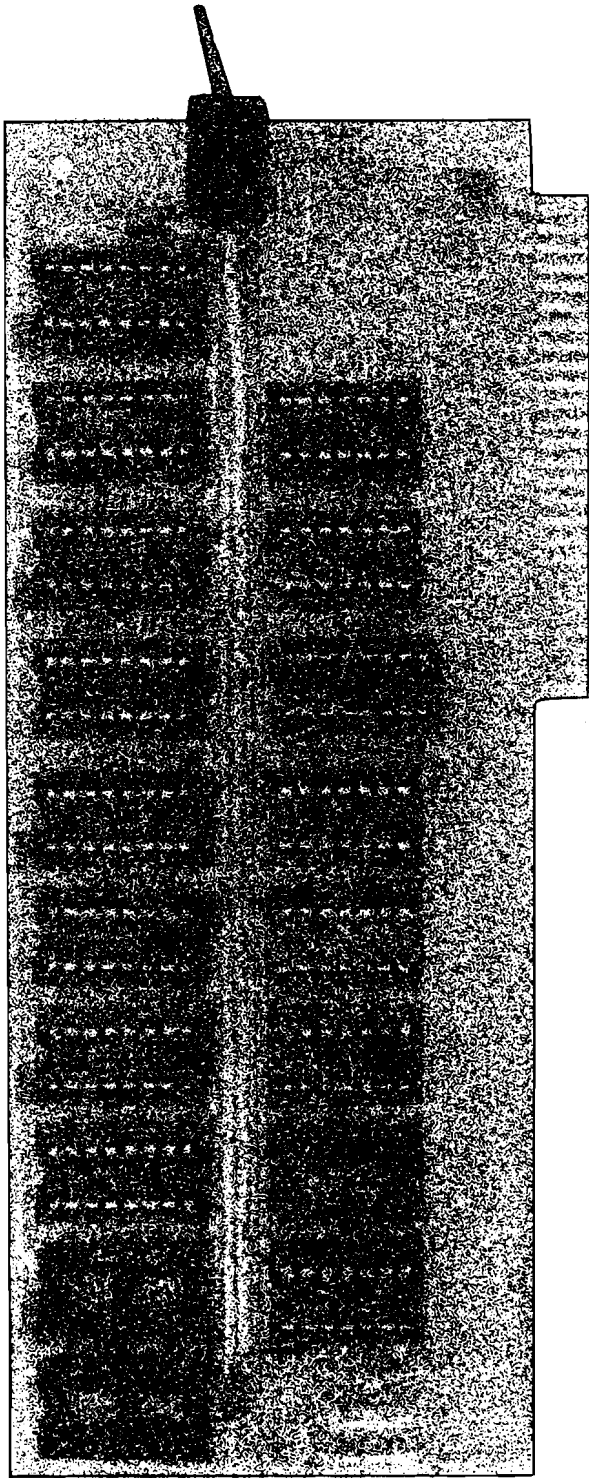

16K RAM Expansion Board for the Apple II* \$195.00

- expands your 48K Apple to 64K of programmable memory
- works with Microsoft Z-80 card, Visicalc, LISA ver 2.0 and other software
- eliminates the need for an Applesoft* or Integer Basic ROM Card
- switch selection of RAM or mother board ROM language
- includes installation and use manual
- fully assembled and tested



Visa and MasterCard accepted
Shipping and handling will be added unless the order is accompanied by a check or money order
N.C. residents add 4% sales tax

*Apple II and Applesoft are trademarks of Apple Computer, Inc.

ANDROMEDA



INCORPORATED**

P.O. Box 19144
Greensboro, NC 27410
(919) 852-1482

**Formerly Andromeda Computer Systems

This Christmas, Why Not Give "The Best"?

The BEST OF MICRO — Volume 3
Just in time for Christmas Giving (and receiving)!

The most substantial MICRO articles — 320 pages organized by major micro-computers. (Covers June 1979 through May 1980)

Suggested Retail — \$10.00

US and Canada

AIM/SYM/KIM: Sharpen Your AIM ★ AIM 8522 Based Frequency Counter ★ Symbol Table Sorter/Printer for the AIM Assembler ★ A Perpetual Calendar Printer for the AIM ★ A Formatted Dump Routine for the AIM 85 ★ A Complete Morse Code Send/Receive Package for the AIM 85 ★ An AIM-85 Notepad ★ Extending the SYM-1 Monitor ★ SYM-1 BASIC "GET" Command ★ SYMple Memory Expansion ★ SYM-1 Staged Loading Technique for Segmented Programs ★ Expanding the SYM-1... Adding an ASCII Keyboard ★ Time of Day Clock and Calendar for the SYM-1 ★ SYM-1 Tape Verification ★ SYM-1 8532 Programmable Timer ★ Dual Tape Drive for SYM-1 BASIC ★ SYMple BASIC Data Files ★ The First Book of KIM — on a SYM ★ Expand KIM-1 Versatility In Systems Applications ★ KIM-1 Tape Recorder Controller ★ Card Shuffling Program for KIM-1 ★ EPROM for the KIM ★ KIM Scorekeeper ★ KIM — The Tunesmith ★ Performing Math Functions in Machine Language ★ Clocking KIM ★ APPLE: The APPLE Stripper ★ Search/Change in Applesoft ★ Assembly Language Applesoft Renumber ★ Data Statement Generator ★ Applesoft Renumbering ★ Common Variables on the APPLE II ★ How to do a Shape Table Easily and Correctly! ★ A Hi-Res Graph-Plotting Subroutine in Integer BASIC for the APPLE II ★ APPLE II Hi-Res Picture Compression ★ Define Hi-Res Characters for the APPLE II ★ An EDIT Mask Routine in Applesoft BASIC ★ Lower Case and Punctuation in APPLESOFT ★ Bi-Directional Scrolling ★ Tape Execute File Create and Use ★ KIM and SYM Format Cassette Tapes on APPLE II ★ A Digital Thermometer for the APPLE II ★ The Color Gun for the Apple II ★ APPLE II Speed Typing Test With Input Time Clock ★ Alarming APPLE ★ Life in the Fast Lane ★ Sorting with the APPLE II ★ Sweet-16 Programming Using Macros ★ What's Where in the APPLE ★ Disassembling the DOS 3.2 ★ Intercepting DOS Errors from Integer BASIC ★ Applesoft II Shorthand ★ APPLE II Floating Point Utility Routines ★ OSi: Challenger II Cassette Techniques ★ Tokens ★ OSi BASIC in ROM ★ Shorthand Commands for Superboard II and Challenger C1P BASICs ★ Polling OSi's Keyboard ★ OSi Fast Screen Erase under BASIC ★ Graphics and the Challenger C1P ★ A Large Digit Clock ★ Plotting and Moving Characters ★ Hypocycloids ★ Some Useful Memory Locations and Subroutines for OSi BASIC in ROM ★ Structured BASIC Editor and Pre-processor ★ Streamlining the C2-4P ★ A Real-Time Clock for OSi Disk Systems ★ How Do You Connect Peripherals to Your Superboard II ★ If You Treat It Nicely It Won't Byte ★ PET/CBM: Case of the Missing Tape Counter ★ Relocating PET BASIC Programs ★ MOVE IT: Relocating PET Source Programs and Object Code ★ A Machine Language Screen Print Program - for the Old (or New) PET ★ A 80X80 Life for the PET ★ Speech Processor for the PET ★ Stop That PET! ★ Boolean Equations Reduced on the PET ★ Reading Pet Cassettes Without a Pet ★ Hooking PET to Ma Bell ★ PET Cassette I/O ★ Plotting a Revolution ★ New and Better PET User Port Printer Routines ★ Multiplexing PET's User Port ★ An Additional I/O Interface for the PET ★ GENERAL: Replace that PIA with a VIA ★ To Tape or Not to Tape: What is the Question? ★ 8522 Timing and Counting Techniques ★ Why a PET, APPLE, 8502 BASIC Compiler? A Simple Explanation ★ The Binary Sort ★ Beginning Boolean: A Brief Introduction to Boolean Algebra for Computerists ★ Subroutine Parameter Passing ★ Program Checksum Calculator ★ A Simple Temperature Measurement Program and Interface ★

At Your MICRO Computer Dealer Now

* Complete your collection—ask about 'Best of' 1 and 2 *

If your dealer does not stock MICRO, you may order direct. All orders must be pre-paid or COD.
(No foreign COD's please)

	US/Canada (Surface)	Foreign (Surface — Air)
Volume 1	7.00	7.00 — 10.00
Volume 2	9.00	9.00 — 13.00
Volume 3	11.00	11.00 — 16.00

All prices quoted are U.S. dollars and include shipping and handling. Orders shipped on date received. Send orders to:

P.O. Box 6502
Chelmsford, MA 01824

MICROSCOPE

Number 5

PBASIC-DS VERSION TWO™

1. Microcomputers which can use product: PBASIC-DS VERSION TWO was written to be used with all Apple II Computers.

2. System hardware requirements: The Apple II Computer should have either 32K or 48K of installed RAM. One disk is required. The program will output to a printer if desired. Thus, a printer is an optional item.

3. System software requirements: The Apple II Computer should have Integer BASIC and also Applesoft floating point BASIC. The floating point BASIC may be either in the RAM or ROM version.

4. Product features: PBASIC-DS makes possible the use of structured programming techniques. Structured programming permits the development of large BASIC programs in either the integer or floating point version. It provides four (4) special logic features which facilitate structured programming: (a) Two Way Conditional Test; (b) Multi-Way Conditional Test; (c) Loops — I. Test Before Loop and II. Test After Loop; (d) Subroutines.

5. Product performance: The system runs well. The disk contains two (2) programs. On command, they both compile, load and run, producing good results. The user is kept advised of the program actions.

6. Product quality: The disk and manual are of good quality with timely interactive advice.

7. Product limitations: The PBASIC system does much that was not possible in BASIC. For what it does, there does not seem to be any shortcoming.

8. Product documentation: The documentation is printed and bound. The material is well organized and easily readable. The manual contains 17 pages consisting of summaries, explanation of principal features and appendices. The manual explains the concepts of structured programming and provides diagrams to characterize important logic mechanisms. Five (5) figures show representative program action. The disk contains two (2) programs to illustrate special PBASIC facilities, "Quicksort" and "Even".

9. Special user requirements: If the user has had any prior experience with FORTRAN or PASCAL he can readily appreciate the power and desirability of structured programming. Still, no supplementary language familiarity is required. The principles involved are well explained in the manual.

The compiler action of PBASIC is very welcome. The organization of a new program is well tested before an attempt is made to execute the program with data.

10. Price/feature/quality evaluation: PBASIC is reasonably priced (\$35.00). The manual, disk and mailing obviously represent some real costs. Apparently the price of PBASIC is based on the expected distribution of several hundred copies.

11. Additional comments: Anybody who has tried to convert a simple FORTRAN program to run in BASIC can appreciate the need for PBASIC-DS. This system gives you several sorely needed logical manipulations; it cleans up and indents the listings and it compiles the program into a RUN-ready BASIC program. This system is in its second offering. Where possible, the editing and compiling are done in RAM, greatly hastening the compile and loading process. Being a second generation system shows up in many of the convenience features that are implemented in the Command Glossary provided to actuate the system.

Systems like PBASIC-DS can do much to improve the professional organization of hobbyist programming efforts.

12. Reviewer: Gordon Thompson, P.E., 724 Kewanna Avenue, Pittsburgh, PA 15234.

13. Manufacturer: Decision Systems, P.O. Box 13006, Denton, TX 76302.

Speed up your PET programming with The BASIC Programmer's Toolkit,™ now only \$39.95.

Don't waste valuable programming time if there's an easier way to go. Here it is: The BASIC Programmer's Toolkit, created by Palo Alto ICs, a division of Nestar. The Toolkit is a set of super programming aids designed to enhance the writing, debugging and enhancing of BASIC programs for your PET.

The BASIC Programmer's Toolkit has two kilobytes of ROM firmware on a single chip. This extra ROM store lets you avoid loading tapes or giving up valuable RAM storage. It plugs into a socket inside your PET system, or is mounted on a circuit board attached on the side of your PET, depending on which model you own.

There are basically two versions of PET. To determine which Toolkit you need, just turn on your PET. If you see *****COMMODORE BASIC;***** your PET uses the TK-80P Toolkit. If you see **###COMMODORE BASIC###**, your PET uses the TK-160 Toolkit. Other versions of the BASIC Programmer's Toolkit are available for PET systems that have been upgraded with additional memory.

How Toolkit makes your programming easier:

FIND locates and displays the BASIC program lines that contain a specified string, variable or keyword. If you were to type **FIND A\$,100-500**, your PET's screen would display all lines between line numbers 100 and 500 that contain **A\$**.

RENUMBER rennumbers the entire program currently in your PET.

You can instantly change all line numbers and all references to those numbers. For instance, to start the line numbers with 500 instead of 100, just use **RENUMBER 500**.

HELP is used when your program stops due to an error. Type **HELP**, and the line on which the error occurs will be shown. The erroneous portion of the line will be indicated in reverse video on the screen.

These simple commands, and the other seven listed on the screen, take the drudgery out of program development work. And for a very low cost. The BASIC Programmer's Toolkit costs as little as \$39.95, or at most, \$59.95.

Get the BASIC Programmer's Toolkit and find out how quick and easy program development can be. See your local PET dealer or send this coupon in today.

Increase your PET's IQ for \$39.95

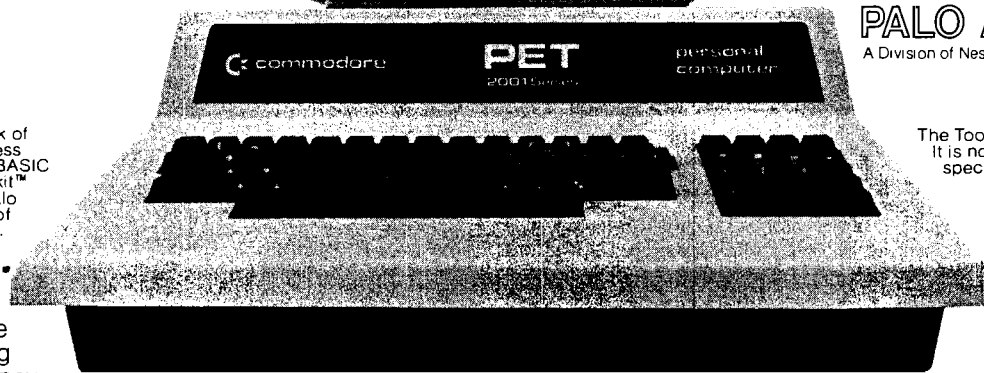
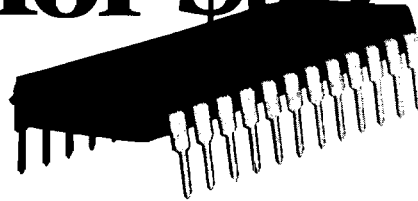

PET™ is a trademark of Commodore Business Machines, Inc. The BASIC Programmer's Toolkit™ is a trademark of Palo Alto ICs, a division of Nestar Systems, Inc.

PALO ALTO ICs
A Division of Nestar Systems, Incorporated

The Toolkit is fully assembled. It is not a kit and requires no special tools to install.

I want to save programming time and money. Send me The BASIC Programmer's Toolkit that will give my PET 10 new and useful commands. Fill in the appropriate line below:

Qty. _____ TK-160 Toolkit(s) @ \$39.95 each
Qty. _____ TK-80P Toolkit(s) @ \$59.95 each

Want to charge it? Call (415) 493-TOOL, or fill out the form below.

Enclosed is a money order check
(If charging): Bill VISA Bill Master Card.

Charge Card _____ Exp. Date _____

Master Card Interbank Number _____

Signature _____

Please include the amount of the Toolkit, plus \$2.50 for shipping and handling. Please allow 4-6 weeks for delivery. **SATISFACTION GUARANTEED, OR SEND IT BACK WITHIN 10 DAYS OF RECEIPT AND PALO ALTO ICs WILL REFUND YOUR MONEY.**

SEND TO:

Name _____

Address _____

City _____ State _____ Zip _____

Phone _____

MAIL TO: Palo Alto ICs
A Division of Nestar Systems, Inc.
430 Sherman Avenue
Palo Alto, CA 94306
(415) 493-TOOL

Dealer inquiries invited.

STUFFIT: A TIME SAVING UTILITY PROGRAM FOR PET BASIC FILES

Use this data-stuffing program on your PET to create a large file system or to expand your present data base—without going to a second cassette.

Roger C. Crites
11880 Rio Grande
St. Louis, MO 63138

Stand-alone data bases, for such applications as recipe files or phone directories, are often based on packed data statements. The preparation, or extension, of such data statements can be expedited with STUFFIT—the data stuffing program. Incorporated within a file program, STUFFIT takes over when you wish to build, or expand the data base.

Upon entry, STUFFIT displays "DATA ENTRY MODE" in reverse field, and the number of bytes of RAM free. A nonblinking cursor appears about halfway down the screen and data to be stored is simply typed in. The delete key may be used in the usual way to correct errors. When the return key is pressed, STUFFIT assigns a line number, applies the "DATA" key word, and programs the new data statement. The number of bytes free is updated, to keep you informed of the remaining memory space. If the line exceeds the 80-character input buffer allowed by PET, STUFFIT supplies an automatic return, and adds an asterisk to the data statement to indicate a continuation to the next data line number. The data line number and basic key word are applied and the new data statement is stored in a completely transparent fashion. The operator simply types in the information he wishes to be stored.

Line 410 clears the screen, displays the amount of free memory, and posi-

tions the cursor. Line 415 turns the video on if it is off. Line 420 gets a character from the keyboard. This character is tested to see if it is a carriage return or an escape (lines 430 and 435). If it is neither, it is added to the input string. The length of the input string is checked to make sure it will not exceed the 80-character limit. Line 450 outputs the current line to the screen and loops back to get the next character. If the input character is a return, the program jumps to line 460, which reads the last data line number and increments it. Line 465 shuts off the video, for appearances, and line 470 positions and prints the input data string on the now dark screen. Line 480 prints the new line number in a data statement. Line 490 prints a direct GOTO command and repositions the cursor so that when the end statement (line 510) is executed, and the program stops, the cursor will lie on the new data line printed by line 470.

Line 500 performs the magic. It tells the PET that the return key has been hit three times. Since the program has stopped, the PET is now in the direct command mode. The screen is blank but the data statement containing the current line number, the line of data to be stored, and a direct GOTO have been printed on the screen. The PET thinks that these lines have been punched in by hand, and the screen editor dutifully passes these lines to BASIC, which modifies the program accordingly. The current line number and the new data are thereby automatically programmed. The direct GOTO is executed, getting STUFFIT running again, collecting input for the next cycle.

On a stand-alone basis, STUFFIT is useful for loading data statements in non-file programs. When writing any program that requires extensive data, I load STUFFIT and use it to enter the required data. I then erase STUFFIT from

memory, leaving the data statements, and proceed with the rest of the program. STUFFIT could, of course, be modified so that when the escape character is hit, it erases itself. However, it is sufficiently short so that manually punching in its line numbers is not very time consuming.

Although very useful in this mode, STUFFIT was written to provide a flexible data entry module for use within BASIC file routines. Specifically, it is intended for use where fast bulk storage disks are not available. It enables the user to rapidly enter new data, and then return to search, sort, or process functions without stopping the program. Upon filing additional data, the program is simply saved on cassette tape. Since STUFFIT automatically appends the new information as data statements, full file support is maintained with a single cassette deck.

To illustrate the symbiotic relationship between STUFFIT and a file program, consider the following—PERSONAL DIRECTORY. This program was written to provide a business file, containing various subcontractors and professional services. It should serve to illustrate the fundamental process, and could easily be modified to provide a custom stand-alone data file for small systems without disk support.

This directory program will search by name or occupation. Under occupation, any additional pertinent information (up to 256 characters) may be stored and retrieved. Searches are based on left-justified string comparison, that is, a search for SM would find Smith, Smothers, and anyone else with a name starting with an SM. A search under occupation for PL would turn up Plumber, Plastic Dealers, etc. Of course, a search for Plumber would only find Plumbers, as a name search for Smith-Joe would only find Joe Smith.

When run, the program asks you to choose between data entry mode and search mode. A backslash is the escape character for either mode. If data entry is selected, the program jumps to STUFFIT (at line 400). To facilitate editing filed information, STUFFIT is slightly modified to add the data line number of each data statement to the information stored in that statement. This is done transparently. The only impact to the programmer is to reduce the number of characters that may be entered before an automatic return is executed. Names, phone numbers, occupations, addresses, and miscellaneous information are simply typed in. STUFFIT functions as previously described, appending the new information as data statements. When the new information is filed, an escape (backslash) returns the program to the mode selection sequence. If the search mode is selected, the program jumps to line 200. This routine asks you to select a name search or an occupation search. Upon receiving the desired name or occupation, the program jumps to a search subroutine at line 1000. This short subroutine performs the actual search. It also checks for the presence of an auto-return flag (asterisk) and joins sequential data statements as necessary, to reproduce the original data string.

The results of the search are passed back to the main routine for display. Upon reaching the end of the file, the program pauses to allow the displayed data to be used. At this point, hitting any key returns the program to the start of the search routine. A backslash will terminate the search mode and return the program to the mode selection sequence. A backslash in the mode selection sequence will stop the program.

If the amount of information to be filed is large, it may be necessary to create two or more volumes: separate tapes. For instance, a name file could be broken into Volume 1, A through M, and Volume 2, N through Z. The amount of information that can be stored in one volume depends entirely on available memory.

STUFFIT and packed data statements allow the user of a PET [without disk drive or second cassette] to achieve much of the utility of larger disk-based systems—at least insofar as phone directories, recipe files, book index files, etc. are concerned. STUFFIT also presents and illustrates a method of altering a program interactively while it is running.

Listing 1

```

5 REM***** PERSONAL DIRECTORY *****
10 ? "cs"TAB(10)"rvPERSONAL DIRECTORY"
20 ?::? TAB(9)"OP MODES & ENTRY CODES"
30 ? TAB(9)"_____ "
40 ? TAB(9)"SEARCH & DISPLAY";TAB(29)"S"
   :?
60 ? TAB(9)"ENTER NEW DATA";TAB(29)"I":?
70 ? TAB(9)"ESCAPE(ANY MODE)";TAB(29)"\"
   :?
80 ?::?"MODE CODE=?"
90 GET A$:IF A$="" GOTO 230
100 IF A$="S" GOTO 200
120 IF A$="I" GOTO 370
130 IF A$="\ " THEN END
140 GOTO 90
200 REM*** SEARCH & DISPLAY ***
210 ?"csrvSEARCH & DISPLAY":?:::RESTORE:
READ LL
220 ?"SEARCH BY NAME(N) OR OCCUPATION (O
   )?"
230 GET A$: IF A$="" GOTO 230
235 IF A$="\ " THEN RUN
240 IF A$="N" GOTO 270
250 IF A$="O" GOTO 280
260 GOTO 230
270 ?:::INPUT"NAME PLEASE";M$:GOTO 290
280 ?:::INPUT"OCCUPATION";M$
290 GOSUB 1000:REM*** GO SEARCH ***
300 IF F%<>1 GOTO 325
310 ?:: N$;TAB(23)"PHONE"P$
320 ? O$:PRINT"FILE LINE NO."L$:?
325 IF FE%=1 THEN ?"rvEND OF FILE":GOTO3
40
330 ?:::GOTO290:REM* CONTINUE SEARCH *
350 GET A$: IF A$="" THEN 350
360 GOTO200
370 ?"csrvDATA ENTRY MODE":?::?
380 ?"DATA MUST BE ENTERED IN THREE FIEL
   DS:"
386 ?::?"FIRST- NAME(LAST NAME FIRST)"
388 ?"SECOND- PHONE NUMBER"
390 ?THIRD- OCCUPATION & MISC. INFO."
392 ?:::?"FIELDS MUST BE SEPARATED WIT
   H A COMMA"
394 ?::?"NO COMMA'S ALLOWED WITHIN A FIEL
   D"
398 GET A$: IF A$="" GOTO398
400 REM***** STUFFIT *****
410 ?"csrvDATA ENTRY MODEof -"FRE(O)"BYT
   ES FREE":?"ch[10cd]":?" "
415 POKE 59409,60
420 GET A$: IF A$="" GOTO 420

```

(Continued)

(Listing 1 continued)

```
430 IF A$=CHR$(13) GOTO460
435 IF A$="\ " THEN RUN
440 R$=R$+A$:IF LEN(R$)<59 GOTO 450
445 R$=R$+"*":GOTO 460
450 ?"ch[10cd]":?R$":GOTO 420
460 RESTORE:READ N:N=N+10
465 POKE 59409,52
470 ?"chcdcdcd"N"DATA"N",R$
480 ?"10000 DATA"N
490 ?"GOTO 410":?"ch"
500 POKE525,3:POKE527,13:POKE528,13:POKE
529,13
510 END
1000 REM*** SEARCH ROUTINE ***
1010 READ L$:REM GET LINE NO.
1015 F%=0:FE%=0:IFVAL(L$)=LL THEN FE%=1
1020 READ N$,P$,O$
1030 IF RIGHT$(O$,1)="*" GOTO1080
1040 IF A$="N" AND M$=LEFT$(N$,LEN(M$))
THEN F%=1:RETURN
1050 IF A$="O" AND M$=LEFT$(O$,LEN(M$))
THEN F%=1:RETURN
1060 IFVAL(L$)=LL THEN F%=0:FE%=1:RETURN
1090 READ C$:O$=LEFT$(O$,LEN(O$)-1)+C$
1100 GOTO 1030
10000 DATA 10000
```

These programs are written for the 2.0 BASIC ROMs. Substitution of line 500 in PERSONAL DIRECTORY will allow it to run with the 3.0 BASIC ROMs.

500 POKE 158,3 : POKE 623,13 :
POKE 624,13 : POKE 625,13

Also remove lines 15 and 65 from STUFFIT. 3.0 BASIC doesn't support screen blanking.

WANTED! Good Articles and Good Photos MICRO Pays Very Well!

As we increase in size—this issue has 96 pages, 16 more than the last—we can include more articles. However, we are becoming more selective about the articles we accept.

MICRO is committed to covering all of the 6502 systems. To do this well, we need a variety of articles on each system. We can always use more high-quality articles relating to AIM, SYM, KIM, Apple, Atari, PET/CBM, and Ohio Scientific systems. We are especially interested in good articles which apply to 6502 systems in general.

Because we plan to use more illustrations than formerly, we encourage authors to "think pictorially" and to send us good line drawings and black and white photos.

We are also looking for black and white photos which might stand alone, with a brief caption. Photos of 6502 systems in unusual business or professional environments would be especially welcome. Photos used independently of articles will be paid for separately.

For details on how to submit manuscripts for possible publication, ask for *MICRO Writer's Guide*. Write or telephone:

Editorial Department
MICRO
P.O. Box 6502
Chelmsford, MA 01824
617/256-5515

PROGRESSIVE COMPUTER SOFTWARE

405 Corbin Rd., York, Pa. 17403
(717) 845-4954

PCS
ANNOUNCING!

SOFTWARE-HARDWARE-SYSTEMS
CUSTOM PROGRAMMING

APPLE & HYDE

ANNOUNCING!

★ DISK HEAD
CLEANING KIT ★

Designed to professionally clean your HDE or APPLE 5-1/4" disk unit heads without disassembling the drive. Available soon for HDE 8" drives.

PCS01DC

HDE5-1/4"

PCS02DC

APPLE 5-1/4"

Complete kit for many cleanings — order now!

\$24.95

until Christmas 21.95

Send SASE for complete catalog or PCS/HDE pgm. library information.

MR. RAINBOW announces...

our all new 1980
catalog and prompts
you to peek at the
latest collection of
software and
hardware products
for your APPLE II™



Write or call today
for your free 1980
catalog.

Garden Plaza Shopping Center
9719 Reseda Boulevard
Northridge, California 91324 (213) 349-5560 Dept. 9MI



Skyles Electric Works

BASIC Programmer's, Toolkit™, Disk-O-Pro™, Command-O™

For PET™ Owners Who Want More Fun And Fewer Errors with Their Programs

Here are thirty-five commands you'll need, all on dual chips you can install in two minutes without tools, on any PET or PET system. 2KB or 4KB of ROM firmware on each chip with a collection of machine language programs available from the time you turn on your PET to the time you shut it off. No tape to load or to interfere with any running programs.

For PET/CBM 2001-8, -8N, -16N/B, -32N/B, 3016 and 3032

BASIC Programmers Toolkit™ commands

**AUTO^{ed} DELETE^{ed} RENUMBER^{ed} HELP^{ed} TRACE^{ed}
STEP^{ed} OFF^{ed} APPEND^{ed} DUMP^{ed} FIND^{ed}**

BASIC Programmers Disk-O-Pro™

**CONCAT^{B80} DOPEN^{B80} DCLOSE^{B80} RECORD^{B80} HEADER^{B80} COLLECT^{B80}
BACKUP^{B80} COPY^{B80} APPEND^{B80} DSAVE^{B80} DLOAD^{B80} CATALOG^{B80}
rename^{B80} SCRATCH^{B80} DIRECTORY^{B80} INITIALIZE^{BS} MERGE^{BS} EXECUTE^{BS}
SCROLL^{ed} OUT^{ed} SET^{ed} KILL^{ed} EAT^{ed} PRINT USING^{BS} SEND^{BS} BEEP^{BS}**

```
RUN
?DIVISION BY ZERO ERROR IN 500
READY
HELP
500 J = SQR(A*B*(%))
READY
```

```
APPEND "INPUT"
PRESS PLAY ON TAPE #1
OK
SEARCHING FOR INPUT
FOUND INPUT
APPENDING
READY
```

```
RUN
READY
DUMP
A1= 10
BW = - 6.1
CS = "HI"
READY.
```

NOTES:

ed — a program editing and debugging command
B80 — a BASIC command also available on Commodore CBM™ 8016 and 8032 computers.
BS — a Skyles Electric Works added value BASIC command.
BASIC Programmers Toolkit™ is a trademark of Palo Alto IC's.
BASIC Programmers Disk-O-Pro™, Command-O™ are trademarks of Skyles Electric Works.
PET™, CBM™ are trademarks of Commodore Business Machines.

Phone or write for information. We'll be delighted to answer any questions
and to send you the complete information package.



Skyles Electric Works

231 E South Whisman Road
Mountain View, CA 94041
(415) 965-1735



Skyles Electric Works

BASIC Programmer's, Toolkit™, Disk-O-Pro™, Command-O™

For CBM™ Owners Who Want More Fun And Fewer Errors with Their Programs

Here are nineteen commands you'll need, on a single chip you can install in two minutes without tools, on any CBM or CMB system. 4KB of ROM firmware on each chip with a collection of machine language programs available from the time you turn on your PET to the time you shut it off.

For CBM 8016 and 8032

BASIC Programmers Command-O™

**AUTO^{ed} DUMP^{ed} DELETE^{ed} FIND^{ed} (improved) HELP^{ed} KILL^{ed} OFF^{ed}
TRACE^{ed} (improved) RENUMBER^{ed} (improved) INITIALIZE^{BS} MERGE^{BS} MOVE^{BS}
EXECUTE^{BS} SCROLL^{ed} OUT^{ed} SET^{ed} SEND^{BS} PRINT USING^{BS} BEEP^{BS}**

```

Section A
100 GOSUB 180
105 PRINT USING CS, A, BS
130 INPUT "TIME": DS
131 INPUT "DAY": ES
160 IFB: C THEN 105
180 FOR X = 1 TO 9
183 PRINT Y(X):NEXT
184 RETURN
200 I = X/19
READY
RENUMBER 110, 10, 105-184
READY
LIST
100 GOSUB 150
110 PRINT USING CS, A, BS
120 INPUT "TIME": DS
130 INPUT "DAY": ES
140 IFB: C THEN 110
150 FOR X = 1 TO 9
160 PRINT Y(X):NEXT
170 RETURN
200 I = X/19
READY

```

```

Section B
MERGE D1 "BUY NOW"
SEARCHING FOR MEMCMP
LOADING
READY
RENUMBER 100, 10
READY
FIND BS
110 PRINT USING AS, SS, SS: CS - DS
200 SS: "NOW IS THE TIME"
READY

```

```

Section D
580 BA BA 1
590 RA 123*5X/92 - BA*10
600 IF BA: 143 THEN 580
610 RETURN
620 CS: "PROFIT $#,#### DAILY"
630 PRINT USING CS, PI
640 DS: "LOSS $#,#### DAILY"
650 PRINT USING DS, LI
RUN
PROFIT $1,238.61 DAILY
LOSS $ 0.00 DAILY
READY

```

```

Section C
180 FOR A = 4096 TO 8191: DOKEA, B: B: B: 1: PRIN
T B: IFB: 255 THEN B: B: 255: PRINT B
TRACE

```

PRICES:

BASIC Programmers Toolkit™ (chip only)	\$40.00
BASIC Programmers Disk-O-Pro™ (chip only)	\$75.00
BASIC Programmers Command-O™ (chip only)	\$75.00
Interface boards (needed sometimes)	\$20.00-\$50.00
Instruction Manual (with redeemable \$5.00 coupon)	\$5.00

Shipping and handling \$2.50 USA/Canada, \$10.00 Europe/Asia

California residents please add 6% or 6-1/2% sales tax as required

Reserve your Disk-O-Pro, Command-O today

Toolkit™ immediate delivery, Disk-O-Pro delivery in December, Command-O delivery in January

VISA, MASTERCHARGE ORDERS CALL (800) 538-3083 (except California residents)

CALIFORNIA ORDERS PLEASE CALL (408) 257-9140



Skyles Electric Works

231 E South Whisman Road
Mountain View, CA 94041
(415) 965-1735

DDJ



DR. DOBB'S JOURNAL of COMPUTER Calisthenics & Orthodontia

Running Light Without Overbyte

Twelve Times Per Year

\$21/1 Year — \$39/2 Years

Recent issues have included:

ZX65: Simulating a Micro

EXOS-6500 Software Development Tool Kit

6502 Assembler—Pet 8K-32K

A Note on 6502 Indirect Addressing

The C Programming Language

What you see is what you get.

To subscribe, send your name and address to *Dr. Dobb's Journal*,
Department V4, Post Office Box E, Menlo Park, CA 94025.
We'll bill you.



PG

MICRO

New Publications

Mike Rowe
New Publications
P.O. Box 6502
Chelmsford, MA 01824

This column lists new publications received for review and also reports on pertinent publication announcements received from book and periodical publishers. Some works mentioned here may be reviewed by MICRO at a later date.

Programming & Interfacing the 6502, With Experiments by Marvin L. DeJong. The Blackburn Continuing Education Series, Howard W. Sams & Co., Inc. (4300 West 62nd St., Indianapolis, Indiana 46168), 414 pages, paperbound.
ISBN: 0-672-21651-5 \$13.95

A book for both 6502 microcomputer novices as well as for knowledgeable 6502 users who want to know more about 6502-based systems available today.

CONTENTS: *Part I: Programming the 6502. Introduction to Microcomputers—Objectives; Introduction; What is a Microcomputer?; The 6502 Microprocessor; Introduction to Experiments; Experiments 1 through 3. Writing and Executing Simple Programs Using Data Transfer Instructions—Objectives; Introduction; Microcomputer Instructions; Addressing Modes; The Microcomputer Program; A Simple Program; Writing a Program; Loading and Executing a Program; The BRK Instruction; The Single-Step Mode; Introduction to the Experiments; Experiments 1 through 7. Simple Input/Output Techniques—Objectives; Introduction; Input/Output Ports; I/O Ports and Data Direction Registers; I/O Port Symbols; Input/Output Programming; JMP Instruction; INC and DEC Instructions; INX, INY, DEX, and DEY Instructions; Introduction to the Experiments; Experiments 1 through 8. Logical Operations—Objectives; Introduction; Logical Operations; AND, OR, and EOR Instructions; Using OR, AND, and EOR Instructions to Control Bit Values; Other Uses of Logical Operations; Introduction to the Experiments; Experiments 1 through 6. Arithmetic Operations—Objectives; Introduction; 6502 Processor Status Register; Flag Modification Instructions; ADC Instruction; Multibyte Addition; Decimal Addition; Twos Complement Arithmetic; Signed Number Arithmetic;*

Signed Arithmetic and Overflow Status Bit; Experiments 1 through 5. Branches and Loops—Objectives; Introduction; Branch Instructions; Modifying the Processor Status Register; Branching; Comparison Instructions; Bit Test Instruction; ASCII to Hexadecimal Conversion; Using Branch Instructions for Time Delays; Introduction to the Experiments; Experiments 1 through 6. Register-Shift Instructions—Objectives; Introduction; Getting Acquainted With Register-Shift Instructions; A 4-Bit Multiplication Program; Hex to ASCII; Decimal to Hexadecimal; Hexadecimal to Decimal; Experiments 1 through 8. Indexed Addressing—Objectives; Introduction; Absolute Indexed Addressing; Zero-Page Indexed Addressing; Data Tables; Code Conversion Programs; Multiple-Byte Arithmetic; Indirect Addressing; Indirect Indexed Addressing Mode; A Simple Monitor; Indexed Indirect Addressing; Introduction to the Experiments; Experiments 1 through 7. Subroutines, the Stack, and Interrupts—Objectives; Introduction; Subroutines; The Stack; Nested Subroutines; Use of the Stack for Storage; Interrupts; Experiments 1 through 7. Interval Timers—Objectives; Introduction; 6530 Interval Timer; 6532 Interval Timer; 6522 Interval Timers; using T2 Timer as a Counter; Using T1 Timer; Precision Timing Program; Using T1 Timer to Implement Frequency Counter; Making Music Using T1 Timer; Experiments 1 through 8. Part II: Interfacing the 6502. Address Decoding—Objectives; Introduction; Address Decoding; Address Decoding for R/W Memory; I/O Port Address Decoding; Address Decoding Circuit for 6522 Interface; 6502 Instructions and Device Select Pulses; Introduction to the Experiments; Experiments 1 through 5. Control Signals, Output Ports, and Applications—Objectives; Introduction; Clock Signals, Φ_0 [IN], Φ_1 [OUT], and Φ_2 [OUT]; R/W Control Signal; Using Control Signals for an Output Port; Memory-Mapped, Latched Hexadecimal Display; Memory-Mapped Digital-to-Analog Converter and an Application to Music Synthesis; Other Control Pins on 6502; Experiments 1 through 5. Data Bus, Buffering, and Applications—Objectives; Introduction; Why Buffer?; Memory-Mapped Analog-to-Digital Converter; An ASCII Keyboard Input Port; Experiments 1 through 5. Applications—Introduction; Digital-Analog and Analog-Digital Conversion Using the KIM-1; Employing the KIM-1 Microcomputer as a Timer and Data Logging Module; Employing the KIM-1 as a Precision Keyer and Automatic Message Sender; Catching Bugs With Lights: A Program Debugging Aid; Lunar Occultation of a Star. Appendix A: Decimal, Binary, and Hexadecimal Number Systems—Objectives; Introduction; Numbers; Decimal Numbers; Binary Numbers; Bits, Bytes, and Nibbles; Hexadecimal Numbers; Exercises; Exercise Answers. Appendix B: Instruction Set Summary. Appendix C: Microcomputer Technical Data. Appendix D: Pin Configuration of Frequently Used SN7400-Series Chips. Appendix E: Pin Configuration of 81LS97. Index.

Microprocessor Systems Engineering by R.C. Camp, T.A. Smay, and C.J. Triska. Matrix Publishers, Inc. (30 NW 23rd Place, Portland, OR 97210), 1979, viii, 642 pages, hardbound.
ISBN: 0-916460-26-6 \$29.95

An introduction to microprocessors for students of electrical engineering. Focuses on the AIM-65 microcomputer, based on the 6502 microprocessor.

CONTENTS: *Introduction to Microcomputer-based Design—Evolution of the Microcomputer; Microprocessor Applications; Engineering Design of Microcomputer-Based Products; Educational Demands Created by the Microprocessor; Objectives of this Book. General Aspects of Microprocessor-Based Systems—Microprocessors and Microcomputers; Classification of Computers and Computer Systems; General Features of Microcomputer-Based Systems; Information Flow in Microcomputers; Central Processor Hardware Elements; Addressing Modes; Microprocessor Instruction Sets; Microprocessor Word Length; Symbolism in Digital Computers; Arithmetic Operations in Microcomputers; Interrupts and Subroutines; Technological Factors in Microprocessors. The 6502 Microprocessor and Peripheral Parts—Introduction to 6502; Programming Model; Data Paths; Concept of Operation of 6502 Instructions; Complete Description of Operation Codes; 6502 Specifications; Peripheral Interface Chips; Example Problems. Software Aids—Introduction; The Software Design Process; Elements of Program Translation; Text Editors; Simulators; Special Program Debug Features; In-circuit Emulation; Logic State Analyzers; Prom Programmers. Microcomputer Interfacing and System Design—Introduction; Guidelines for System Design; Miscellaneous Advice on System Design; Interfacing Examples; Input; Output-TTL, Speed, Bits, Serial Parallel Conversions; Address Maps and Organization; Memory and I/O Selection; System Design Examples. Introduction to the 6502 Microprocessor—Introduction; Principal Characteristics; Some 6502 and 6800 Differences; 6800 Programming; Electrical Characteristics of the 6800; 6800 Microcomputer Example; Example Problems. Introduction to 8080 Microprocessor—Characteristics; 8080 Architecture and Programming Model; Data Paths; 8080 Instruction Set; 8080 Example Program; Electrical Characteristics of the 8080. A Case Study—The AIM 65—Introduction; Memory Interfacing; LED Display Interface; Keyboard Interfacing; Printer Interface; Teletype Interface; Interrupt Handling; User Port Interfacing; Monitor Subroutines. A: A 6502 Based Microprocessor—The AIM-65; B: The System 65—A 6502 Development System; C: 2's Complement Arithmetic in the 6502; Index.*

MICRO



VersaWriter

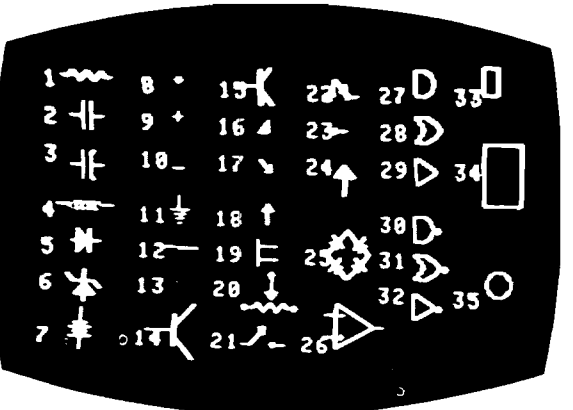
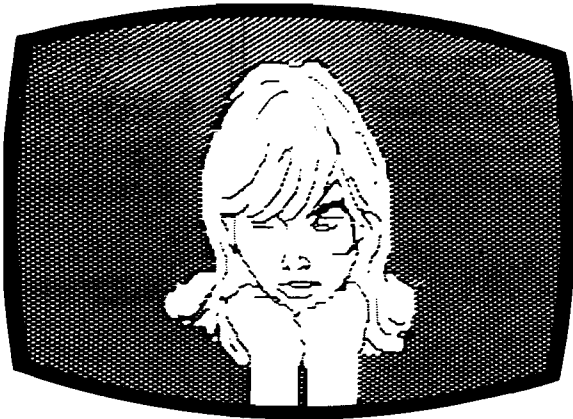

What is VersaWriter?

- VersaWriter is an inexpensive drawing tablet for the APPLE II that lets you trace a picture and have it appear on TV display.
- VersaWriter is a comprehensive software drawing package which lets you color in drawings with over **100** different colors.
- VersaWriter is a shape compiler that converts anything on the screen automatically into a standard shape table.
- VersaWriter is a text writer for labeling pictures with text in six colors and five sizes. Use English or Greek, upper or lower case letters.
- VersaWriter is much more! Draw with brush, create schematic drawings, compute area and distance, edit pictures, save, recall and more.

VersaWriter requires ROM APPLESOFT and 48K memory.
\$249 Suggested Retail

UNIQUE OFFER

Send us YOUR disk and \$1. We will promptly return the disk with a slide package of 10 color pictures drawn with VersaWriter.

Enclosed is \$1 and my disk. Send me the slide package.

Send more information including VersaWriter dealers in my area.

DEALER INQUIRIES INVITED.

NAME

ADDRESS

CITY STATE ZIP

Send To: Versa Computing, Inc. • 887 Conestoga Circle • Newbury Park, CA 91320 • (805) 498-1956

MICRO

Microprocessors in Medicine: The 6502

By Jerry W. Froelich, M.D.

The column this month and last month, written together with Jack W. Smith, M.D., informs readers on various uses of computers in medical education and provides examples of how the 6502 microprocessor is able to perform tasks in medical education nearly as well as large computer systems. (Dr. Smith is a Clinical Fellow in Pathology, Instructor in Allied Health, and Ph.D candidate in Computer Science at Ohio State University, Columbus, Ohio.)

Last month, we described various types of programs: computer-aided instruction [CAI], computer-assisted evaluation [CAE], and simulation. This month, we will cover "APPLE-ED," a program produced by Computer Methods Supplements [CMS, of Ann Arbor, Michigan] for educating physicians and technologists in nuclear cardiology.

Last month, no mention was made of problems with computers in medical education, and there are some disadvantages. Therefore, before we move on to the APPLE-ED, let's discuss the problems. The lack of uniformity in computer systems makes transfer of programs difficult. Lack of agreement of information content in programs increases the difficulty of transfer. At present, there is no formal production-distribution system to make available the programs which exist. Prior to the development of microprocessors, computer-aided instruction required large computer systems. Currently, there are three large medical institutions with large investments in computers for use in medical education. They are the Massachusetts General Hospital in Boston, Massachusetts, the University of Illinois at Urbana, and Ohio State University in Columbus, Ohio.

At all three institutions, the students interact with a CRT terminal which is connected to the host computer via telephone lines. Personnel not based at the institutions have limited access.

With the advent of microprocessors and languages such as BASIC and PILOT, the production-distribution

system for medical knowledge is potentially enhanced. However, consistently-updated, high-quality material is still not available.

One application which I would like to describe is called, APPLE-ED. This is a microprocessor-based system produced by Computer Methods Supplements. APPLE-ED is, as the name implies, written for an APPLE computer.

The programs are written in BASIC and are designed so that once the system has been "booted up," the program will sequence itself through the three floppy disks to a fourth disk which is a testing program. The APPLE-ED programs present a series of complete lectures on the use of computers in Nuclear Medicine and Nuclear Cardiology. (Perhaps at a future time we can give an in-depth description of computer applications in nuclear medicine.) The lecture content is based on the textbook entitled, *Computer Methods: The Fundamentals of Digital Nuclear Medicine*, published by C.V. Mosby Company and edited by David E. Liberman of CMS.

The three sections of the APPLE-ED programs are: "Basic Elements of Computers"; "Display and Processing of Nuclear Medicine Studied"; and "Nuclear Cardiology Techniques." The examination disk is structured so that the participant takes an examination. The results are recorded on the disk, and at some point the disk is returned to CMS for grading.

At Massachusetts General Hospital, the residents and visiting fellows use the system and have found it an excellent introduction to the field of computers in nuclear medicine.

Summary

We have reviewed the types of computer programs in medical education (CAI, CAE, etc.) and concluded with a description of APPLE-ED, a 6502 application. APPLE-ED requires no hardware more sophisticated than a microcomputer and a disk drive. The disk is only required to make the loading of the programs quicker. If you are willing to tolerate the speed of tape, then tape is a viable storage medium.

The programs are written in BASIC, which allows text to be printed and which queries the user on the content of the material presented. Based upon the participant's response, the program then branches. It either progresses further into the material or reinforces points, and reviews material that has already been covered.

To quote a user of APPLE-ED, "It sounds quite beneficial for us. We don't have a training program for technologists, but our residents could benefit from the continuing education, and it's a fraction of the cost of sending someone to a clinical seminar. Thanks for your help!" (APPLE-ED can be either purchased or leased from Computer Methods Supplements.)

Note to Readers

Thank you for the response to my first column. I will begin to incorporate suggestions into future columns. Anyone wishing to share his application, please drop me a line. I must apologize, but because of the number of letters, if you would like a response please include a stamped, self-addressed envelope. Please send all correspondence to me at: c/o Massachusetts General Hospital, Boston, MA 02114.

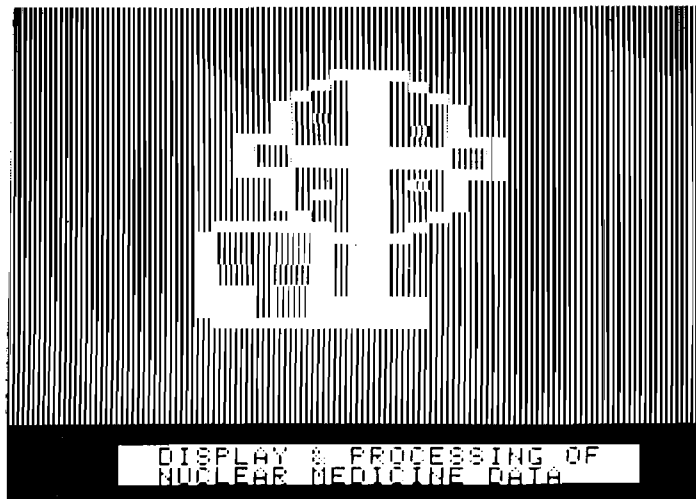



The Newest In

Apple Fun

We've taken five of our most popular programs and combined them into one tremendous package full of fun and excitement. This disk-based package now offers you these great games:

Mimic—How good is your memory? Here's a chance to find out! Your Apple will display a sequence of figures on a 3 x 3 grid. You must respond with the exact same sequence, within the time limit.

There are five different, increasingly difficult versions of the game, including one that will keep going indefinitely. Mimic is exciting, fast paced and challenging—fun for all!

Air Flight Simulation—Your mission: Take off and land your aircraft without crashing. You're flying blind—on instruments only.

A full tank of fuel gives you a maximum range of about 50 miles. The computer will constantly display updates of your air speed, compass heading and altitude. Your most important instrument is the Angle of Ascent/Bank Indicator. It tells if the plane is climbing or descending, whether banking into a right or left turn.

After you've acquired a few hours of flying time, you can try flying a course against a map or doing aerobic maneuvers. Get a little more flight time under your belt, the sky's the limit.

Colormaster—Test your powers of deduction as you try to guess the secret color code in this Mastermind-type game. There are two levels of difficulty, and three options of play to vary your games. Not only can you guess the computer's color code, but it will guess yours! It can also serve as referee in a game between two human opponents. Can you make and break the color code...?

Star Ship Attack—Your mission is to protect our orbiting food station satellites from destruction by an enemy star ship. You must capture, destroy or drive off the attacking ship. If you fail, our planet is doomed...

Trilogy—This contest has its origins in the simple game of tic-tac-toe. The object of the game is to place three of your colors, in a row, into the delta-like, multi-level display. The rows may be horizontal, vertical, diagonal and wrapped around, through the "third dimension". Your Apple will be trying to do the same. You can even have your Apple play against itself!

Minimum system requirements are an Apple II or Apple II Plus computer with 32K of memory and one minidisk drive. Mimic requires Applesoft in ROM, all others run in RAM or ROM Applesoft.

Order No. 0161AD \$19.95

Paddle Fun

This new Apple disk package requires a steady eye and a quick hand at the game paddles! It includes:

Invaders—You must destroy an invading fleet of 55 flying saucers while dodging the carpet of bombs they drop. Your bomb shelters will help you—for a while. Our version of a well known arcade game! Requires Applesoft in ROM.

Howitzer—This is a one or two person game in which you must fire upon another howitzer position. This program is written in HIGH-RESOLUTION graphics using different terrain and wind conditions each round to make this a demanding game. The difficulty level can be altered to suit the ability of the players. Requires Applesoft in ROM.

Space Wars—This program has three parts: (1) Two flying saucers meet in laser combat—for two players, (2) two saucers compete to see which can shoot out the most stars—for two players, and (3) one saucer shoots the stars in order to get a higher rank—for one player only. Requires Applesoft.

Golf—Whether you win or lose, you're bound to have fun on our 18 hole Apple golf course. Choose your club and your direction and hope to avoid the sandtraps. Losing too many strokes in the water hazards? You can always increase your handicap. Get off the tee and onto the green with Apple Golf. Requires Applesoft.

The minimum system requirement for this package is an Apple II or Apple II Plus computer with 32K of memory and one minidisk drive.

Order No. 0163AD \$19.95

Solar Energy For The Home

With the price of fossil fuels rising astronomically, solar space-heating systems are starting to become very attractive. But is solar heat cost-effective for you? This program can answer that question.

Just input this data for your home: location, size, interior details and amount of window space. It will then calculate your current heat loss and the amount of gain from any south facing windows. Then, enter the data for the contemplated solar heating installation. The program will compute the NET heating gain, the cost of conventional fuels vs. solar heat, and the calculated payback period—showing if the investment will save you money.

Solar Energy for the Home: It's a natural for architects, designers, contractors, homeowners... anyone who wants to tap the limitless energy of our sun.

Minimum system requirements are an Apple II or Apple II Plus with one disk drive and 28K of RAM. Includes AppleDOS 3.2.

Order No. 0235AD (disk-based version) \$34.95

Math Fun

The Math Fun package uses the techniques of immediate feedback and positive reinforcement so that students can improve their math skills while playing these games:

Hanging—A little man is walking up the steps of the hangman's noose. But YOU can save him by answering the decimal math problems posed by the computer. Correct answers will move the man down the steps and cheat the hangman.

Spellbinder—You are a magician battling a computerized wizard. In order to cast death clouds, fireballs and other magic spells on him, you must correctly answer problems involving fractions.

Whole Space—Pilot your space craft to attack the enemy planet. Each time you give a correct answer to the whole number problems, you can move your ship or fire. But for every wrong answer, the enemy gets a chance to fire at you.

Car Jump—Make your stunt car jump the ramps. Each correct answer will increase the number of buses your car must jump over. These problems involve calculating the areas of different geometric figures.

Robot Duel—Fire your laser at the computer's robot. If you give the correct answer to problems on calculating volumes, your robot can shoot at his opponent. If you give the wrong answer, your shield power will be depleted and the computer's robot can shoot at yours.

Sub Attack—Practice using percentages as you maneuver your sub into the harbor. A correct answer lets you move your sub and fire at the enemy fleet.

All of these programs run in Applesoft BASIC, except Whole Space, which requires Integer BASIC.

Order No. 0160AD \$19.95

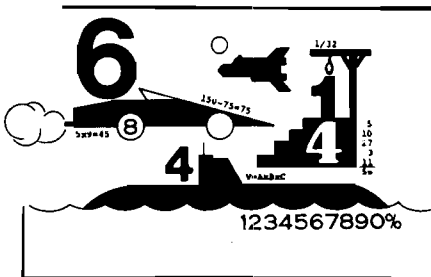

Skybombers

Two nations, separated by The Big Green Mountain, are in mortal combat! Because of the terrain, their's is an aerial war—a war of SKYBOMBERS!

In this two-player game, you and your opponent command opposing fleets of fighter-bombers armed with bombs and missiles. Your orders? Fly over the mountain and bomb the enemy blockhouse into dust!

Flying a bombing mission over that innocent looking mountain is no milk run. The opposition's aircraft can fire missiles at you or you may even be destroyed by the bombs as they drop. Desperate pilots may even ram your plane or plunge into your blockhouse, suicidally.

Flight personnel are sometimes forced to parachute from badly damaged aircraft. As they float helplessly to earth, they become targets for enemy missiles.

The greater the damage you deal to your enemy, the higher your score, which is constantly updated at the bottom of the display screen.

The sounds of battle, from exploding bombs to the pathetic screams from wounded parachutists, remind each micro-commander of his bounden duty. Press On, SKYBOMBERS—Press On!

Minimum system requirements: An Apple II or Apple II Plus, with 32K RAM, one disk drive and game paddles.

Order No. 0271AD (disk-based version) \$19.95



*A trademark of Apple Computer Inc.

PETERBOROUGH, N.H. 03458
603-924-7296

Instant Software™

Apple* Software

From Instant Software

Santa Paravia and Fiumaccio

Buon giorno, signore!

Welcome to the province of Santa Paravia. As your steward, I hope you will enjoy your reign here. I feel sure that you will find it, shall we say, profitable.

Perhaps I should acquaint you with our little domain. It is not a wealthy area, signore, but riches and glory are possible for one who is aware of political realities. These realities include your serfs. They constantly request more food from your grain reserves, grain that could be sold instead for gold florins. And should your justice become a trifle harsh, they will flee to other lands.

Yet another concern is the weather. If it is good, so is the harvest. But the rats may eat much of our surplus and we have had years of drought when famine threatened our population.

Certainly, the administration of a growing city-state will require tax revenues. And where better to gather such funds than the local marketplaces and mills? You may find it necessary to increase custom duties or tax the incomes of the merchants and nobles. Whatever you do, there will be far-reaching consequences... and, perhaps, an elevation of your noble title.

Your standing will surely be enhanced by building a new palace or a magnificent *cattedrale*. You will do well to increase your landholdings, if you also equip a few units of soldiers. There is, alas, no small need for soldiery here, for the unscrupulous Baron Peppone may invade you at any time.

To measure your progress, the official cartographer will draw you a *mappa*. From



it, you can see how much land you hold, how much of it is under the plow and how adequate your defenses are. We are unique in that here, the map IS the territory.

I trust that I have been of help, signore. I look forward to the day when I may address you as His Royal Highness, King of Santa Paravia. *Buona fortuna* or, as you say, "Good luck". For the Apple 48K.

Order No. 0174A \$9.95 (cassette version).

Order No. 0229AD \$19.95 (disk version).

TO ORDER SEE YOUR LOCAL INSTANT SOFTWARE DEALER OR USE THE ORDER FORM BELOW

For Fast Service

call now

Toll-Free

1-800-258-5473

Apple Cassettes

- 0018A Golf.....\$7.95
- 0025A Mimic.....\$7.95
- 0040A Bowling/Trilogy.....\$7.95
- 0073A Math Tutor I.....\$7.95
- 0079A Oil Tycoon.....\$9.95
- 0080A Sahara Warriors.....\$7.95
- 0088A Accounting Assistant.....\$7.95
- 0094A Mortgage w/Prepayment Option/
Financier.....\$7.95
- 0096A Space Wars.....\$7.95
- 0098A Math Tutor II.....\$7.95
- 0174A Santa Paravia and Fiumaccio.....\$9.95
- 0148A Air Flight Simulation.....\$9.95

We Guarantee It!

Instant Software Guarantee

OUR PROGRAMS ARE GUARANTEED TO BE QUALITY PRODUCTS. IF NOT COMPLETELY SATISFIED YOU MAY RETURN THE PROGRAM WITHIN 60 DAYS. A CREDIT OR REPLACEMENT WILL BE WILLINGLY GIVEN FOR ANY REASON.

109

Name _____

Address _____

City _____ State _____ Zip _____

Check Money Order VISA AMEX Master Charge

Card No. _____ Exp. Date _____

Signed _____ Date _____

Order your Instant Software today!

Quantity	Order No.	Program name	Unit cost	Total cost
Shipping and handling				\$1.00
Total order				

Instant Software Inc.

Peterborough, N.H. 03458

OUR UNIQUE DESIGN PHILOSOPHY

MORE is **MORE**

WE PACK MORE FEATURES ON EVERY BOARD

This multi-purpose expansion board provides memory expansion of up to 48K and includes an EPROM programmer, two versatile interface adapters, and a prototyping area. DRAM PLUS is fully compatible with AIM, SYM, KIM (ASK) microcomputers.

FEATURES

16 or 32K new generation dynamic RAM with all refresh handled on the board and completely transparent to ASK microcomputers. Memory addressable in independent 4K segments placed on 4K boundaries.

Provisions provided for four ROMs or EPROMs - up to 16K nonvolatile memory. EPROM Programmer for 2716/2516 2K EPROMs, and 2732/3532 4K EPROMs. EPROMs programmed under automatic voltage control.

2 Versatile interface adapters (VIAs) provide 40 I/O lines brought out to the edge connector, 4 timers, and 2 shift registers. Prototype area provides space and support for the addition of special circuits.

Requires only +5V at 1 amp and any voltage between +12 and +24 at 150 milliamps. -5V is generated on board.

—DRAM PLUS—

BENEFITS

ASK microcomputers can handle more complex software tasks and store significantly more data. Added memory may be contiguous with existing memory. Nonvolatile memory further expands the use and application of microcomputers.

DRAM PLUS provides users all the hardware and software required to produce EPROMs.

The VIAs enables users to interface keyboards, printers, and other devices to DRAM PLUS and/or the microcomputer.

The prototyping area enables users to add memory write protection, multiplex EPROM's, or control other application specific devices.

Your existing power supply is probably adequate to run DRAM PLUS.

DEALER AND OEM QUANTITY DISCOUNTS AVAILABLE

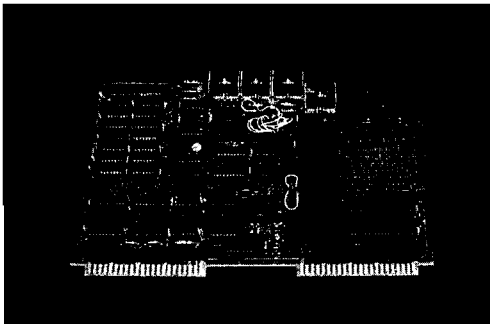

DRAM PLUS: 16K RAM-\$295, 32K RAM-\$395.



VIDEO PLUS II: Standard Board \$295, Options: 4K RAM-\$50, 6502 Stand-alone Processor-\$20, Communications Provision-\$35.

The most versatile and complete instant video expansion board for AIM, SYM, KIM (ASK) microcomputers. Includes many unique video features plus general purpose and communications interfaces, 2K EPROM and up to 7K RAM. With the 6502 microprocessor option, VIDEO PLUS II can function as a stand-alone terminal.

FEATURES

ASK VIDEO PLUS™ Software EPROM works with Monitors, BASIC, Editors and observes all standard programming conventions. Fast scrolling and flicker-free operation supports AIM keyboard, upper and lower case, or any ASCII keyboard. Software fully supports VIDEO PLUS II options.

EPROM character generators provide for 128 character set with 2716 EPROM, or 256 character set with user furnished 2532. Programmable Character Size. Selective character blank/unblank. Improved keyboard Interface. Reverse Video.

Optional System Features are: 2K display RAM, 2K program character generator, 6502 stand-alone processor, ACIA communications provision.

—VIDEO PLUS II—

BENEFITS

Instant video display capability. Simple cable connection provides for easy installation and immediate use: simply "plug in and go". Standard options are available to meet user's requirements for future major system improvements.

Display requirements may be tailored to meet actual application requirements on an individual basis. User may specify character set, height, width and spacing in accordance with specific application display and man/machine requirements. 2000-4000 characters or limited, high resolution graphic screen displays.

VIDEO PLUS II supports major system enhancements which can significantly extend user's product life cycle. Any combination of options may be specified. Additional capability may be added to meet changing application requirements or planned product line improvements.

All prices shown are US and Canadian only, and are exclusive of shipping charges and applicable taxes. Other improved products now available include: MOTHER PLUS II, PROTO PLUS II, POWER A PLUS II, and AIM PLUS II. For more information, contact:

THE COMPUTERIST®
34 Chelmsford St., Chelmsford, MA 01824
617/256-3649

ATARI BITS

128 colors on the screen at one time? Explore some of the many, extraordinary features ATARI provides, but doesn't always tell you about.

Len Lindsay
1929 Northport #6
Madison, WI 53704

Atari Safari

The ATARI 400 and 800 computers are quite amazing machines. The more I learn about them, the more amazing they seem. They offer 3 different text modes and 6 different graphic modes. But they don't tell you that you can mix and match different modes on the screen at the same time. BASIC allows you to use any 6 of the 128 possible colors at one time, but did you know that it is possible to have all 128 on the screen at one time?

I hope to share information and programming tips with you, to help you use your ATARI computer for amazing things. So let's get started. This month I will explain some quick little programming tricks and methods. Watch for a future article explaining the things I have mentioned. If you have any ATARI programming tips you would like to share please contact me:

Len Lindsay
c/o MICRO, P.O. Box 6502
Chelmsford, MA 01824

TV Screen Protect Feature

If you leave the same exact picture on your TV screen for an extensive period of time, it will "burn" an image into the screen. This can ruin your good color TV set. ATARI realized this

when they designed their computers, and built in a feature to protect your screen. If you don't hit a key on the keyboard for several minutes, the computer goes into attract mode, changing the color registers every several seconds. The screen image remains the same, just the colors change, dark to light, to medium, etc. Changing the colors helps to prevent the image from "burning" into your screen.

Memory location 77 is used by the ATARI as a sort of counter, and is reset to 0 each time the keyboard is accessed. Every few seconds it increments by one. When it reaches 128, the computer goes into attract mode. You may write a program that uses a joystick for input, or one that continually generates dynamic computer art. Thus several minutes will go by without any keyboard access, but you do not want the colors to begin changing. To prevent it, just add this one line in the appropriate place:

```
200 POKE 77,0 : REM RESET  
ATTRACT MODE COUNTER  
TO ZERO
```

When this line is executed, the computer thinks a key has been hit, and the counter is reset back to zero. Of course you can do the exact opposite and start attract mode at any time as well. Just use this line:

```
500 POKE 77,128 : REM START  
ATTRACT MODE
```

When executed, the computer will go into attract mode, changing the color registers every few seconds, providing you with an easy method to have your screen change colors.

Keyboard Buffer

The ATARI is always looking at its keyboard, even while doing other things under program control. It remembers the last key hit. For example, if you hit the "A" key while the computer is drawing something on the

screen, it will remember that you hit the key. ENTER THIS PROGRAM:

```
10 REM BUSY WORK  
PROGRAM  
20 FOR DELAY = 1 TO 999  
30 NEXT DELAY
```

Now RUN the program, and hit the "A" key while it is thinking. When the program is done, watch an A appear on the screen. The computer remembered that you hit the key. Try it again, but hit several keys. Only the last key you hit will be remembered. This feature has its uses, but can be annoying at times. For instance, an INPUT statement in your program will use the key in the keyboard buffer as the first character of the INPUT. Try the following program:

```
10 REM CHEATING ON THIS IS  
EASY  
15 PRINT "HIT A KEY WHEN I  
SAY GO"  
20 FOR DELAY = 1 TO  
RND(1)*500 + 500  
30 NEXT DELAY  
40 PRINT  
50 PRINT "GO"  
60 OPEN #1,4,0,"K:" :REM  
OPEN THE KEYBOARD FOR  
A GET COMMAND  
70 GET #1,KEY :REM WAIT TILL  
A KEY IS HIT  
80 CLOSE #1 :REM CLOSE FILE  
90 PRINT "THANK YOU"
```

RUN the program. Hit a key after it says GO, and it will respond THANK YOU. However, you can cheat very easily. Just hit a key immediately after you RUN the program.

There is an easy way to prevent cheating of this nature. Add this one line to your program and try to cheat:

```
65 POKE 764,255 : REM CLEAR  
KEYBOARD BUFFER
```

It is always a good idea to use this statement just before any INPUT in your program, for example:

```

100 PRINT "WHAT IS YOUR
AGE":
110 POKE 764,255
120 INPUT AGE

```

Clearing the buffer makes sure that you have a fresh start for your INPUT.

Dynamic Keyboard

You just saw how to clear the keyboard buffer. Now, what if you would like to add something to it? This may seem like a silly idea, but I will show that it is very practical. Your program can list an individual line of your program to disk with this command:

```

600 LIST "D:LIST",10 :REM
LIST LINE 10 TO DISK—
FILE NAME 'LIST'

```

Your program will continue executing after this command is executed. Line 10 can be a line of DATA or some other varying aspect of your program.

You also can ENTER new program lines from disk, *while the program is running*. The program can thus change itself as it RUNs. This line will ENTER a new line 10 into the program (if a line 10 was previously put to disk with the LIST command):

```

700 ENTER "D:LIST" : REM
ENTER NEW PROGRAM
LINES FROM DISK

```

However, after the program executes an ENTER command, it stops program execution, and waits for keyboard commands. To have the program continue executing you would then have to type in:

```
CONT
```

There is a way to have all this done automatically for you. All we have to do is trick the computer into thinking that you just typed in CONT (or a GOTO command) and hit RETURN. First, here is a program that will record line 99 in your program onto disk:

```

10 REM LIST LINE 99 TO DISK
20 PRINT "RECORDING LINE
99 TO DISK"
30 LIST "D:LINE99",99
40 PRINT "DONE —"
99 PRINT "THIS IS LINE 99"

```

RUN this program. It will save line 99 to DISKETTE. We will use it for input to the next program.

Now here is a program that will ENTER program lines from diskette,

thus altering itself while it is running. (Remember to type NEW first.)

```

10 REM ENTER PROGRAM
LINE FROM DISKETTE
20 PRINT "READING LINE
FROM DISK"
30 PRINT "[DOWN][DOWN]
GOTO 50[UP][UP]";
35 POKE 764,12 : REM TRICK
ATARI TO THINK YOU HIT
THE RETURN
40 ENTER "D:LINE99"
50 PRINT "DONE —"

```

Run this program with the diskette still in your drive. Surprise! It printed DONE and also THIS IS LINE 99. Try the program without line 35. It still will add line 99 from diskette, but quits executing at that point.

NOTE: the above program requires cursor movements to be programmed into line 30. [DOWN] means to program in one cursor down. Do not type it in literally. To program in a cursor down, simply hit the ESC key, then hit CONTROL CURSOR DOWN. The same applies to [UP], which means program in one cursor up.

ATARI High Resolution Text

The ATARI lets you enjoy every high resolution graphics mode—GRAPHICS 8. Normally, the screen can only plot points. However, this routine can be used to put text on the screen along with your graphic display. Here is the subroutine:

```

23000 ZL = PEEK(560) +
PEEK(561)*256
23020 ZM = PEEK(ZL + 4)
+ PEEK(ZL + 5)*256
23030 FOR ZW = 1 TO
LEN(ZA$)
23040 ZT = 57344 +
((ASC(ZA$(ZW,
ZW)-32)*8)
23050 ZC = ZM + ZY*40 +
ZX+(ZW-1)
23060 FOR ZR=0 TO 7
23070 POKE ZC+ZR*40,
PEEK(ZT+ZR)
23080 NEXT ZR
23085 ZY=ZY+ZZ
23090 NEXT ZW
23099 RETURN

```

Notice that all variables used begin with Z. That means that conflicts with variables in your main program will probably not occur, or you will be alerted to each Z variable you use.

ZA\$ is the text to be printed
ZX is the column to start printing (0–39)
ZY is the row to start printing (0–191)
ZZ is the slant of the printed line
ZL, ZT, ZC, ZW, ZR are temporary variables used

To utilize the routine, simply set ZA\$ to the text you want, set ZX and ZY to the starting coordinate and GOSUB 23000. If you want your text printed in a straight line, ZZ should equal 0. Try ZZ=1 and ZZ=-1. An example line to call the subroutine might be this:

```

500 ZA$="TESTING TEXT"
:ZX=5:ZY=40:ZZ=1
:GOSUB 23000

```

You might wish to fool with the subroutine to make it print wavy lines:

```
23085 ZY=ZY+ZZ:ZZ=-ZZ
```

You can also fool with the concepts in the routine to print the text in vertical lines as well as horizontal.

Upper, or Lower, or Graphics

Graphics mode 2 is the large TEXT mode. ALL PRINT#6 commands are printed to the screen in extra large size. For example:

```

10 GRAPHICS 2 : REM LARGE
TEXT MODE
20 PRINT#6;"TESTING"

```

The word TESTING is printed on the screen in large gold letters. Now try the same program, but change line 20 so that the word you print is in lower case letters. Example:

```

10 GRAPHICS 2 : REM LARGE
TEXT MODE
20 PRINT#6;"testing"

```

This time the word TESTING is printed on the screen in large light green letters. But the letters are all upper case. Next, try typing the word TESTING in reverse field. (Hit the ATARI symbol key just before typing the first letter in the word TESTING. After typing the word TESTING in reverse field, hit the ATARI symbol key again to be back to normal.) Try printing both UPPER and lower case letters in reverse field.

You now see that you can get 4 different colored UPPER case large letters on the screen by varying how you type them in the PRINT statement. But

what if you really want lower case letters on the screen? Simple, one POKE will do the trick:

```
POKE 756,226 : REM LOWER
CASE CHARACTER BASE
```

Type in that POKE statement after running your program. Surprise!

Everything Is Upside Down

With one simple command you can turn all of the characters on the screen upside down. And from that point on, all characters printed will also be upside down. Just enter this command:

```
POKE 755,4 : REM UPSIDE
DOWN CHARACTERS
```

Now type anything you want and watch it come out upside down. Hit the SYSTEM RESET button, and all will return to normal. Or enter this command:

```
POKE 755,2 : REM BACK TO
NORMAL
```

This can be used within a program for special effects. Try this quick example:

```
10 GRAPHICS 2 : REM LARGE
TEXT MODE
20 POSITION 9,9 : REM
STARTING POINT FOR
PRINTING WORD
30 PRINT#6;"TESTING"
40 X=2 : REM INITIALIZE
VARIABLE FOR POKES
100 POKE 755,X : REM UPSIDE
DOWN AND THEN BACK
AGAIN
110 FOR DELAY=1 TO 200 :
REM PAUSE A SECOND
120 NEXT DELAY
130 X=6-X : REM SWITCH
FROM 2 TO 4 AND THEN
BACK FROM 4 TO 2
140 GOTO 100 : REM DO IT
AGAIN
```

I think you will enjoy the example that was just mentioned. Hit the BREAK key while the word is upside down. Isn't it interesting that the message

```
STOPPED AT LINE 110
```

is often printed upside down?

MICRO

MICRO

Letterbox

Dear Editor:

In the April MICRO, (23:65) Mr. Earl Morris wrote an interesting article on OSI BASIC in ROM. I have a disk system, but I was interested in the same for my Disk BASIC, which, I might add, really lacks a memory map. So I started to use the program under the assumption the two BASICs were generally the same, and they are—right down to the AND, OR, GREATER, LESS, and EQUAL. The only difference being the area of memory occupied. The following is what is required to make Earl's program work for the Disk BASIC.

```
10 Q=1:D=644
20 FOR C=512 TO 612 STEP 2
115 D=776
120 FOR C=614 TO 641
STEP 3
```

Note: By changing Line 120 in the ROM version to:

```
FOR C=41062 TO 41089
STEP 3
```

you will find the missing AND, OR, GREATER, LESS, and EQUAL.

Les Cain
2606 Grand Ave.
Grand Junction, Colorado 81501

Dear Editor:

I appreciated Mr. Childress' article in the May issue (24:45) on entering lowercase and punctuation into Applesoft strings, but I would like to point out that it is possible to enter punctuation into INPUT strings without the use of special routines. If the string is enclosed in quotation marks [e.g., "HALL, C.W."] all characters between the quotation marks will be accepted as part of the string. The only character I have not been able to enter this way is the quotation mark ["], which delimits the string. However, if the string is not delimited with quotation marks, they may be entered anywhere in the string.

I discovered this use of the quotation marks in Applesoft when I needed to enter a list of names, last name first, and remembered how such strings were entered in BASIC on the DEC and CDC machines I programmed in college. I know this information will be a great help to all those Applesoft users who have been trying to enter commas and colons into their strings.

Charles W. Hall
3262 Olive Place
Fort Worth, Texas 76116

Dear Editor:

I thought your readers might be interested in a slightly more enhanced version of EDITPLUS. All of the original features are the same, plus the following: (1) 'ESC' 'H' will clear and home the screen, (2) 'ESC' 'P' performs a POKE 33,33 to change the screen width to 33 columns for easier editing of literals (string values inside quote marks) and (3) 'ESC' 'N' returns the screen width to a normal 40 columns. Listed below is a memory dump of the improved version, located at \$300. Just type it in and 'CALL 768'. It's set up for use with 48K of memory and 3.2 DOS. To revise it for other configurations, see the EDITPLUS article in the June issue of MICRO and the necessary revisions will be apparent.

It sure makes editing easier, and it works in Integer BASIC, Applesoft and in the Monitor. Also, the enhancements make it of value to the owners of APPLE II Plus computers.

```
0300— A9 13 85 38 A9 03 85 39
0308— A9 69 85 36 A9 03 85 37
0310— 4C 51 A8 20 1B FD C9 9B
0318— F0 0B 60 38 E9 C9 A8 B9
0320— 8C 03 20 2C FC A4 24 B1
0328— 28 48 29 3F 09 40 91 28
0330— 68 20 1B FD C9 C8 D0 02
0338— A9 C0 C9 D0 F0 18 C9 CE
0340— F0 10 B0 19 C9 C9 90 15
0348— C9 CC D0 CF 20 51 A8 4C
0350— 65 FF A9 28 D0 05 20 42
0358— FC A9 21 85 21 38 20 2C
0360— FC A4 24 8C 5B AA 4C 0C
0368— FD 84 35 C9 8D D0 18 AC
0370— 00 C0 10 13 C0 93 D0 0F
0378— 2C 10 C0 AC 00 C0 10 FB
0380— C0 83 F0 03 2C 10 C0 A4
0388— 35 4C F0 FD C4 C2 C1 FF
0390— C3
```

Craig Peterson
1743 Centinela Ave. #102
Santa Monica, California 90404

Continued on page 94

A JOURNAL FOR OSI USERS!!

The Aardvark Journal is a bimonthly tutorial for OSI users. It features programs customized for OSI and has run articles like these:

- 1) Using String Variables.
- 2) High Speed Basic On An OSI.
- 3) Hooking a Cheap Printer To An OSI.
- 4) An OSI Disk Primer.
- 5) A Word Processor For Disk Or Tape Machines.
- 6) Moving The Disk Directory Off Track 12.

Four back issues already available!
\$9.00 per year (6 issues)

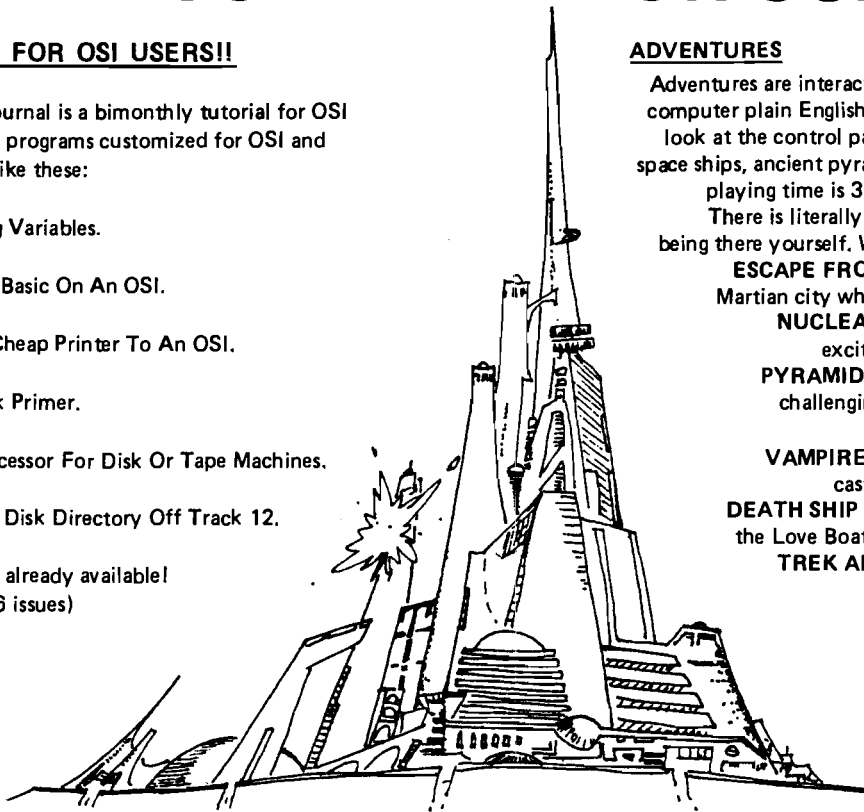
ADVENTURES

Adventures are interactive fantasies where you give the computer plain English commands (i.e. take the sword, look at the control panel.) as you explore alien cities, space ships, ancient pyramids and sunken subs. Average playing time is 30 to 40 hours in several sessions.

There is literally nothing else like them — except being there yourself. We have six adventures available.

ESCAPE FROM MARS — Explore an ancient Martian city while you prepare for your escape.

NUCLEAR SUBMARINE — Fast moving excitement at the bottom of the sea.

PYRAMID — Our most advanced and most challenging adventure. Takes place in our own special ancient pyramid.

VAMPIRE CASTLE — A day in old Drac's castle. But it's getting dark outside.

DEATH SHIP — It's a cruise ship — but it ain't the Love Boat and survival is far from certain.

TREK ADVENTURE — Takes place on a familiar starship. Almost as good as being there.

\$14.95 each

NEW SUPPORT ROMS FOR BASIC
IN ROM MACHINES

C1S — for the C1P only, this ROM adds full screen edit functions (insert, delete, change characters in a basic line.), Software selectable scroll windows, two instant screen clears (scroll window only and full screen.), software choice of OSI or standard keyboard format, Bell support, 600 Baud cassette support, and a few other features. It plugs in in place of the OSI ROM. NOTE: this ROM also supports video conversions for 24, 32, 48, or 64 characters per line. All that and it sells for a mesly \$39.95.

C1E/C2E for C1/C2/C4/C8 Basic in ROM machines.

This ROM adds full screen editing, software selectable scroll windows, keyboard correction (software selectable), and contains both an extended machine code monitor and a fix for the string handling bug in OSI Basic!! It has breakpoint utilities, machine code load and save, block memory move and hex dump utilities. A must for the machine code programmer replaces OSI support ROM. Specify system! \$59.95

STRING BUG FIX (replaces basic ROM chip number 3)

All this chip does is to replace the third basic ROM and correct the errors that were put into the ROM mask. \$19.95

DATA SHEETSOS65D LISTING

Commented with source code, 83 pages. \$24.95

THE (REAL) FIRST BOOK OF OSI

65 packed pages on how OSI basic works. Our best selling data sheet. \$15.95

OSI BASIC IN ROM

Ed Carlson's book of how to program in basic. Now available from Aardvark. \$8.95

P.C. BOARDS

MEMORY BOARDSII — for the C1P. — and they contain parallel ports!

Aardvark's new memory board supports 8K of 2114's and has provision for a PIA to give a parallel port! It sells as a bare board for \$29.95. When assembled, the board plugs into the expansion connector on the 600 board. Available now!

REAL SOUND FOR THE C1P — and it's cheap!

This bare board uses the TI sound chip to give real arcade type sound. The board goes together in a couple of hours with about \$20.00 in parts. Bare board, plans, and sample program — \$15.95

ARCADE AND VIDEO GAMES

ALIEN INVADERS with machine code moves — for fast action. This is our best invaders yet. The disk version is so fast that we had to add selectable speeds to make it playable.

Tape — \$10.95 — Disk — \$12.95

TIME TREK (8K) — real time Startrek action. See your torpedoes move across the screen! Real graphics — no more scrolling displays. \$9.95

STARFIGHTER — a real time space war where you face cruisers, battleships and fighters using a variety of weapons. Your screen contains working instrumentation and a real time display of the alien ships. \$6.95 in black and white - \$7.95 in color and sound.

SEAWOLFE — this one looks like it just stepped out of the arcades. It features multiple torpedoes, several target ships, floating mines and real time time-to-go and score displays. — \$6.95 in black and white \$7.95 in color and sound.

SCREEN EDITORS

These programs all allow the editing of basic lines. All assume that you are using the standard OSI video display and polled keyboard.

C1P CURSOR CONTROL — A program that uses no RAM normally available to the system. (We hid it in unused space on page 2). It provides real backspace, insert, delete and replace functions and an optional instant screen clear. \$11.95

C2/4 CURSOR. This one uses 366 BYTES of RAM to provide a full screen editor. Edit and change lines on any part of the screen. (Basic in ROM systems only.)

FOR DISK SYSTEMS — (65D, polled keyboard and standard video only.)

SUPERDISK. Contains a basic text editor with functions similar to the above programs and also contains a renumberer, variable table maker, search and new BEXEC* programs. The BEXEC* provides a directory, create, delete, and change utilities on one track and is worth having by itself. — \$24.95 on 5" disk - \$26.95 on 8".

DISK UTILITIES

SUPER COPY — Single Disk Copier

This copy program makes multiple copies, copies track zero, and copies all the tracks that your memory can hold at one time — up to 12 tracks at a pass. It's almost as fast as dual disk copying. — \$15.95

DISK CATALOGER

This utility reads the directory of your disks and makes up an alphabetic list off all your programs and what disks they are on. \$14.95

MACHINE CODE RENUMBERER

(C2/4-MF only)

Renumbers all or part of a program at machine code speeds. — \$15.95



This is only a partial listing of what we have to offer. We now offer over 100 programs, data sheets, ROMS, and boards for OSI systems. Our \$1.00 catalog lists it all and contains free program listings and programming hints to boot.



Aardvark Technical Services • 1690 Bolton • Walled Lake, MI 48088

(313) 669-3110 or (313) 624-6316

Relocating OSI ROM BASIC Programs

This BASIC program relocater will help users of Ohio Scientific computers with BASIC in ROM to better understand how their Microsoft BASIC and monitor are used.

William L. Taylor
246 Flora Road
Leavittsburg, OH 44430

Two articles recently published in MICRO inspired this article. The article entitled "Some Useful Memory Locations and Subroutines for OSI BASIC in ROM" by S.R. Murphy, that appeared in the November 1979 MICRO (18:9), gave a list of zero page locations used by the Ohio Scientific Challenger computers as a scratch pad memory. This memory map along with the article "Relocating PET BASIC Programs" by Michael Tulloch, that appeared in the December 1979 MICRO (19:25), inspired me to try a BASIC program relocater for Ohio Scientific computers.

To begin with, since Microsoft wrote the BASIC that is used in Ohio Scientific Challengers and Commodore PET computers, it would seem there would be similarities. This is true. Both versions of BASIC use low memory in the same manner as a scratch pad. Zero page, for example, is used as a scratch pad to store BASIC's parameters. A list or memory map for the Challengers and PET is listed in table 1. From the table it can be seen that both the Challengers and PET use the same pointers. There are differences between the version for the PET and the one for the Challengers and how they use some locations in zero page; but both versions use identical pointers for memory allocation, for the beginning of BASIC work space, etc. One difference between the versions is that Ohio Scientific uses page 3

of the system memory as a part of BASIC program memory workspace.

Ohio Scientific computers with BASIC in ROM perform the same tests on memory as do PETs. That is, hex 24 is loaded into memory locations from 0301 hex upwards, depending on the memory size. When Ohio Scientific's BASIC in ROM machines are brought up under cold start, the user may define memory size or allow BASIC to utilize all the available memory in the system from hex 0301 upward.

After BASIC tests memory for available space and determines the upward limit, this available size is stored in a zero page location called the memory size pointer. On initialization, there are several other parameters set up in the scratch pad memory in zero page under ROM BASIC. These parameters are called pointers. We have already used this term and have defined two of these pointers. Ohio Scientific ROM BASIC always sets its pointers to begin at 0301 hex or 769 decimal for a starting point.

**Table 1:
Relocating Ohio Scientific BASIC Programs**

Similarities in PET and Ohio Scientific Scratch Pad

The Commodore PET has BASIC program work space set to begin at 0401 hex. Ohio Scientific has the BASIC work space set to begin at 0301 hex.

	Scratch Pad Area			
	PET		OSI	
<i>BASIC START</i>	122 dec.	7A hex	121 dec.	79 hex
	123 "	7B "	122 "	7A "
<i>Single Variable</i>	124 "	7C "	123 "	7B "
	125 "	7D "	124 "	7C "
<i>Array Variable</i>	126 "	7E "	125 "	7D "
	127 "	7F "	126 "	7E "
<i>Array Space Available</i>	128 "	80 "	127 "	7F "
	129 "	81 "	128 "	80 "
<i>String Bottom</i>	130 "	82 "	129 "	81 "
	131 "	83 "	130 "	82 "
<i>String Top</i>	132 "	84 "	131 "	83 "
	133 "	85 "	132 "	84 "
<i>Memory Size</i>	134 "	86 "	133 "	85 "
	135 "	87 "	134 "	86 "
<i>Present BASIC Line</i>	136 "	88 "	135 "	87 "
	137 "	89 "	136 "	88 "
<i>Line # at BREAK</i>	138 "	8A "	137 "	89 "
	139 "	8B "	138 "	8A "
<i>Pointer For CONT.</i>	140 "	8C "	139 "	8B "
	141 "	8D "	140 "	8C "

As was noted by Mr. Tulloch in his article on relocating PET BASIC programs, there are several pointers in the scratch pad memory that must be changed to initiate a relocation of BASIC programs. These pointers are: the beginning of BASIC program; the beginning of the single variable; the beginning of array variables; the available space for DIM array variable; and, finally, the top of strings and the bottom of strings. All of these pointers must be changed to point to the location for a BASIC program, if a new starting area is to be used. As stated before, the listing in table 1 will show the location in the scratch pad where the pointers are located. In addition, I will describe how to use these pointers to allow you to relocate your Ohio Scientific BASIC programs.

The Ohio Scientific Microsoft BASIC in ROM uses addresses hex 79 and 7A or decimal 121 and 122 as the BASIC start pointer locations. On a BASIC cold start, these locations contain a pointer that points to hex 0301 or decimal 769. The data stored in these locations must be in the 6502 format, that is, low byte followed by the high byte (for example, 0079 01 007A 03). All the pointer locations are two bytes wide and must have their data in this format. As an example, if you wished to have your BASIC program start at, say, hex 0400, then this address would have to be stored in 0079 and 007A as 00,04. To relocate your programs to start at 0400 hex, you would have to change all the pointers in the same manner. The seven pointers that must be changed are listed in table 1.

As an example, let's reinitialize the pointers in zero page for a BASIC program start address to begin at 0800 hex. To have the program begin at 0800 hex, we will need to change the high byte of the pointers for BASIC program start, simple variable start, array variable start, available space, and string top and string bottom. To make this change, bring up BASIC in cold start. Reset the computer. Bring up Monitor Mode by typing "M" on the keyboard. Once in Monitor Mode, you can call up the pointer addresses and change the data, to point to the new BASIC program starting point. In address mode, call up 007A hex. Enter Data Mode by typing a slash (/) on the keyboard. Now load the required data at this address, in this case hex 08. Enter hex 08 at locations 007C, 007E, and 0080. Return to Address Mode. Call up 0800 hex. Examine the data stored at 0800. If this data is not 00, then change this data to read hex 00. Reset the computer. Call

up BASIC in warm start with "W" on the keyboard. Now type NEW followed by RETURN. If all went well the computer should respond with OK. Your BASIC work space has now been changed to begin at page 8 and your BASIC programs will be written upward from this point.

The last example is only one method of re-initializing the pointers. A different approach to this task is demonstrated in program listing 1. This program provides a BASIC and machine language program that can be saved on cassette tape and can be loaded into the CIP or other Ohio Scientific system when the need arises. Refer to listing 1 for the following description.

The BASIC portion of the program is used as an executive in connection with the machine language routine that actually does the work in initializing the scratch pad area pointers. The machine code program is stored in the memory area between 0200 hex and 0300 hex. This area in memory is little used and rarely mentioned in most articles. The memory area between 0222 and 02FF hex is not used by BASIC or the Ohio Scientific monitor and is free for machine language routines or any other machine coded programs that can fit into this area. This is a perfect location for our machine code routine used in this program. Once the machine code routine is stored in this area, it can be called at any time the need

BASIC Program Relocator

```

5 REM OSI ROM BASIC PROGRAM RELOCATOR
7 PRINT" ROM BASIC PROGRAM RELOCATOR"
10 FOR Q=546 TO 573
20 READ P: POKE Q,P
30 NEXT Q
50 INPUT" START";A
60 POKE 547,A
70 POKE 570,A
80 POKE 11,34:POKE 12,2
90 X=USR(X)
100 DATA 169,0,133,122,133,124,133,126
110 DATA 133,128,133,144,133,173,133,165
120 DATA 133,167,133,196,169,0,141,0,0
130 DATA 76,0,0

```

Disassembled Object Code Located at 0222 through 023D.

0222	A9 00	LDA	#\$00
0224	85 7A	STA	\$007A
0226	85 7C	STA	\$007C
0228	85 7E	STA	\$007E
022A	85 80	STA	\$0080
022C	85 90	STA	\$0090
022E	85 AD	STA	\$00AD
0230	85 A5	STA	\$00A5
0232	85 A7	STA	\$00A7
0234	85 C4	STA	\$00C4
0236	A9 00	LDA	#\$00
0238	8D 00 00	STA	\$0000
023B	4C 00 00	JMP	\$0000

arises to re-initialize the BASIC start pointers. The BASIC program in listing 1 contains the parameters needed to store the machine code in user memory and provides for user input in changing the BASIC pointers.

At line 10 through 30, the machine code program is stored in user memory beginning at hex 0222 or decimal 546. The machine code is stored in the BASIC program in DATA statements at lines 100 through 130. These data are READ and POKEd into memory with the FOR... NEXT loop at lines 10 through 30. The remainder of the BASIC program simply obtains the operator's input for a new BASIC start address. This start address is obtained at line 50 and stored in the "A" variable. At line 60 and 70, this new ad-

dress data is stored or POKEd into the machine code areas at 0223 or 547 decimal and 023A or 570 decimal. The USR vector is set at line 80 to point to the machine code routine beginning at 0222 hex or 546 decimal. Line 90 is a statement using the USR function of BASIC. This statement causes a jump through the USR vector to 0222 hex and executes the machine code routine.

When the program is run, the pointers will be changed to reflect the new start address. When the machine code program has reset the pointers, it jumps to BASIC warm start at hex 0000 or decimal 0. The C1P responds with OK. To set up the new BASIC work space, simply type NEW and a carriage return.

Once the BASIC program in listing 1 has been keyed into the C1P or other Ohio Scientific computer, you should SAVE the program on cassette tape for later use. This cassette program can be loaded into any relocated BASIC program space, as can any SAVED BASIC program. The Ohio Scientific SAVE and LOAD cassette commands can be used regardless of where you have relocated your BASIC program workspace.

In conclusion, I believe this information will help owners and users of Ohio Scientific computers with BASIC in ROM to better understand how the Ohio Scientific Microsoft BASIC and the OSI monitor are used. Good luck.

MICRO



American Data

*The world's largest distributor of
Ohio Scientific Microcomputers*

ANNOUNCES

The availability of the new Ohio C2-D and C3-D (10 MB 8" hard disk units) and the C1P Series 2 converted by American Data for European power.

American Data is the exclusive distributor of OSI microcomputers to Europe. Dealer inquiries invited: Contact Barbara Hall 352-23-172 Luxembourg or David O'Brien (301) 840-9540 Telex: 64405 (USA).

OHIO SCIENTIFIC USERS

SOFTWARE - GAME AND UTILITY PROGRAMS FOR AS LOW AS \$1.00. ALL WITH LISTINGS AND COMPLETE DOCUMENTATION.

KITS - UPDATE YOUR COMPUTER TO PLAY MUSIC, INCREASE OPERATING SPEED, HIGH RESOLUTION GRAPHICS AND MUCH MORE. KITS INCLUDE PARTS AND COMPLETE ASSEMBLY INSTRUCTIONS. LOW AS \$3.00.

OUR \$1.00 CATALOG INCLUDES OSI PROGRAMMING TIPS PLUS DESCRIPTIONS OF AVAILABLE PROGRAMS AND KITS.

MITTENDORF ENGINEERING 905 VILLA NUEVA DR. LITCHFIELD PARK, AZ 85340



OUR UNIQUE MARKETING PHILOSOPHY

MORE for **LESS**

WE PROVIDE PRODUCTS FOR COST-EFFECTIVE SOLUTIONS

A fully featured mother board with a standardized bus, full buffering, address decoding for adding up to 5 expansion boards to AIM, SYM, KIM (ASK) microcomputers. MOTHER PLUS II is also a microcomputer support board providing connections for power, TTY, audio cassettes, and cassette control relays.

FEATURES

—MOTHER PLUS II—

BENEFITS

All address lines, data lines and control lines are buffered. Address control manager resolves host/peripheral address contention.

Address decoding and full buffering provides the necessary interface to easily add boards to increase microcomputer capabilities. No microcomputer hardware changes are required when boards are added via MOTHER PLUS II.

System I/O is supported with connectors for TTY and audio cassettes; relays to control two cassette recorders; Port A and Port B socket; LED audio input monitor, and more.

Simple switch settings prevent bus contention between the microcomputer and expansion boards.

Standard 44 pin edge connectors provide interconnection for 5 expansion boards.

The standard bus eliminates cables and permits more compact and efficient packaging.

Large terminal strip provides GND, +5V, +12V, 1 user defined voltage, and TTY I/O.

The terminal strip simplifies connections and supports special user requirements.

DEALER AND OEM QUANTITY DISCOUNTS AVAILABLE

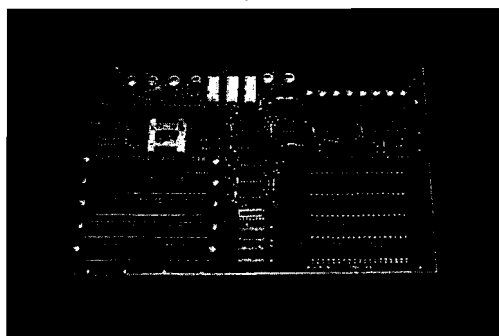

MOTHER PLUS II: \$100.



PROTO PLUS II: Unassembled-\$45, Assembled-\$60.

This expansion board product provides for the efficient design, development, checkout, and interface of digital design logic to AIM, SYM, KIM (ASK) microcomputers.

FEATURES

—PROTO PLUS II—

BENEFITS

Full Size board with plated through holes and gold-plated fingers. Triple pad geometry permits solder connectors as well as wire wrap. Universal .1 grid pattern with GND and +5V conveniently bussed throughout the board. Additional patterns to permit quick insertion of a wide range of discrete components, voltage regulators, 25 pin "D" subminiature plug (RS 232), common transistors, switches, etcetera.

Product development times are improved.

Standard interface has circuits for address buffers, bi-directional tri-state buffers, 8K bank address decoding, and control signal buffers.

The PROTO PLUS II board is designed to facilitate construction and assembly.

Engineers can now concentrate their efforts on new design work as standard interface circuitry and components are available as standard options. Time previously lost due to long and sometimes costly order and delivery cycles is avoided.

All prices shown are US and Canadian only, and are exclusive of shipping charges and applicable taxes. Other improved products now available include: DRAM PLUS, VIDEO PLUS II, POWER A PLUS II, and AIM PLUS II. For more information, contact:

 **THE
COMPUTERIST®**
34 Chelmsford St., Chelmsford, MA 01824
617/256-3649

Cassette I/O for SYM BASIC

Expand the capabilities of SYM BASIC with this cassette I/O handler. Access your cassette as a data file—not just as a place to save programs.

Nicholas J. Vrtis
5863 Pinetree S.E.
Kentwood, MI 49508

CASSETTE I/O FOR SYM BASIC

One of the features I missed when I started working with BASIC on the SYM was the lack of any program input or output capability to the cassette. It seemed a shame to use up a lot of memory with DATA statements which were only used once to initialize an array. They use up a lot of memory fast, since they don't get compressed much. For any type of inquiry program, even a lot of memory isn't enough. Ten minutes of cassette will hold around 90,000 characters, more than the total 6502 address space.

One Method

I considered two methods of getting the data to and from the cassette. The first was to take the data directly from BASIC's variable area. It wasn't hard to snoop around BASIC enough to find out how and where it kept variables. The usage in BASIC would have been via two USR functions; one to read, and one to write. The only argument would have been a string containing the variable name. The assembler routine to write to tape would have been almost trivial after the variable data area was located. The SYM monitor routines

only need a starting and ending address. This method also had the advantage of being able to save a large array in one write to the cassette, with no data conversion. It would, however, have been a very inefficient way to handle a non-dimensioned variable (at the rate of four bytes at a time), since you do need some SYNC bytes and leader for motor startup each time you write to the tape. There are many problems that come up, moreover, when you want to read the stuff back in. The SYM routines need to know both the starting and ending address, if you want to read data back into a different area from whence it came. Due to the way BASIC dynamically allocates variables, it wouldn't be a safe bet to count on everything being in the same place as it was when written. Finding the beginning address to go back to wouldn't be too hard, since the input to the read routine would be the variable to read into, and we can find that. The ending address could again be calculated from the BASIC data, but it has to be the same length as before. For numeric data, that is easy to control with a DIM statement. Strings complicate the process even further, since their length is determined by use, not a DIM statement. Of course, one could always rewrite the SYM routines to accept starting address and length as a parameter list. I decided that there had to be an easier way.

Another Method

The second method is a little harder to use in BASIC, but turns out to have a couple of extra uses I hadn't planned on. The idea was to make the cassette respond similarly to the paper tape reader/punch on an ASR Teletype. For those unfamiliar with the beast, there are four control characters used to turn the paper

tape on and off (usually called DC1 through DC4) from a remote terminal or computer. The plan was to intercept all the terminal I/O via the INVEC and OUTVEC system RAM vectors, and look for these characters to control data to or from a cassette buffer. This would mean that INPUT and PRINT statements could be used to get at the cassette. After experimenting with this for a while, I decided to make a separate routine which took care of turning cassette input and output mode on and off. This made the routines transparent to any character. (But beware, INCHR does some things after a character is obtained.) It also simplified making the output from a BASIC program suitable as input to BASIC.

The Routines Described

Since the routines intercept data via INVEC and OUTVEC, they are usable with any software written for the standard SYM, such as TINY BASIC or assembler programs. Except for the first and last buffers, filling and emptying is taken care of automatically, so you don't have to worry about how much data will fit in one buffer. In fact, data can extend from one buffer to the next and your program would never know the difference. It even turns out that the routines can be used for a "free" merge for BASIC programs. Simply LIST the programs to the cassette, and then read them back in. BASIC will think you are entering the lines from the terminal and sort the line numbers, etc.

There are four separate "entry points" in these routines. INITIT takes care of initialization and setup; CTURN handles turning cassette mode on and off, and forcing first and last buffer handling; CHRIN replaces INTCHR as the vector address for

SYM input; and finally, CHROUT handles character output in place of TOUT. INITIT and CTURN are the only two called directly by the user. The other two are used indirectly by normal input and output.

INITIT Starts the Process

INITIT really has two purposes in life. The first and foremost is to put the address of CHRIN and CHROUT into INVEC and OUTVEC in system RAM. This could have been done with a couple of SD monitor commands, but these are messy to do when you are in BASIC. The second purpose is to initialize the current FILEID to zero. Additionally, the routine also saves the current OUTVEC address in three spare system RAM locations. This is because I have a separate routine to drive my Quick Printer II, and I want to be able to use both routines. Normally, INITIT would only be called once, but it still checks to make sure it doesn't have its own address already in OUTVEC. If it saved this as the terminal output address, things could get circular.

Do's and Don'ts

For INITIT, don't have trace on while it is executing. Trace will try to use OUTVEC after it gets half changed. The program assumes that CHRIN and CHROUT start on the same page (\$OF currently). If you end up relocating it to someplace where this isn't true, you will have to add some code to put in the correct starting page for one of the routines. INVEC is not saved anywhere. If you have a custom input routine, you will have to add code to save it, and change the JSR INTCHR at \$F2B to use it. If you decide not to save OUTVEC, you will have to change the JSR NUVEC at \$F41 and \$F87 to a JSR TOUT (@ \$8AA0). INITIT doesn't require any parameters, and it doesn't attempt to save or restore any registers. BASIC takes care of that for itself. You will have to watch it if you are using the routines from assembler. Obviously, it must be called before any data will go to the buffer. It may be called more than once, but any previous data in the buffer may be lost (see the discussion of input parameter value 3 for CTURN).

CTURN Controls I/O Routine

The routine CTURN is used as a common entry point for controlling the status of the I/O routines. I chose to use a single entry point for two reasons.

Listing 1

CASSETTE I/O ROUTINES FOR SYM-1 BASIC

SYM-1 MONITOR CALLS

1000	INTCHR	*	\$8A58	TERMINAL INPUT ROUTINE
1000	LODCAS	*	\$85F3	LOAD FROM CASSETTE
1000	SAVCAS	*	\$87EA	WRITE TO CASSETTE
1000	GETKEY	*	\$88AF	GET KEY FROM HEX PAD
1000	ERMSG	*	\$8171	OUTPUT "ER XX" MESSAGE
1000	ACCESS	*	\$8B86	UNPROTECT SYSTEM RAM

SYM-1 MONITOR VARIABLES

1000	INVEC	*	\$A661	RAM INPUT VECTOR
1000	OUTVEC	*	\$A664	RAM OUTPUT VECTOR
1000	NUVEC	*	\$A646	UNUSED BYTES IN SYS RAM
1000	TECHO	*	\$A653	TERMINAL ECHO CONTROL
1000	TAPDEL	*	\$A630	TAPE LEADER TIMER
1000	P3L	*	\$A64A	TAPE PARAMETER 3
1000	P3H	*	\$A64B	
1000	P2L	*	\$A64C	PARAMETER 2
1000	P2H	*	\$A64D	
1000	P1L	*	\$A64E	PARAMETER 1
1000	P1H	*	\$A64F	

0E00			ORG	\$0E00	
------	--	--	-----	--------	--

0E00	PZBIDX	*	\$00FA	BUFFER INDEX POINTER
0E00	PZCURR	*	\$00FB	CURRENT BUFFER ID #
0E00	BUFLen	*	\$00FA	BUFFER LENGTH CONSTANT

BUFFER AREA - FIRST BYTE IS MAX INDEX VALUE

0E00 00	BUFFER	=	\$00	
---------	--------	---	------	--

0EFA			ORG	\$0EFA	BUFFER IS 250 BYTES
------	--	--	-----	--------	---------------------

TURN ON/TURN OFF ROUTINES

0EFA 20 86 8B	CTURN	JSR	ACCESS	UNPROTECT SYS RAM
0EFD 98		TYA		MOVE OVER & CHECK SIGN
0EFE F0 18		BEQ	NEWBF	TO FORCE NEW BUFFER
0F00 30 0D		BMI	CTOFF	TO TURN TAPE OFF
0F02 0D 53 A6		ORA	TECHO	OTHERWISE TURN IT ON
0F05 C0 03		CPY	#\$03	CHECK FOR BUFFER RESET
0F07 D0 0B		BNE	TURNF	NO - STORE NEW VALUE
0F09 20 C2 0F		JSR	NWRITE	YES - SET UP POINTERS
0F0C C6 FA	ADJUST	DEC	PZBIDX	ADJUST POINTER TO START
0F0E 60		RTS		
0F0F 88	CTOFF	DEY		CHANGE -1 TO FE, -2 TO FD
0F10 98		TYA		PUT IN A REGISTER
0F11 2D 53 A6		AND	TECHO	TURN OFF ECHO BIT
0F14 8D 53 A6	TURNF	STA	TECHO	STORE NEW VALUE
0F17 60		RTS		DONE
0F18 AD 53 A6	NEWBF	LDA	TECHO	READ OR WRITE?
0F1B 29 01		AND	#\$01	TRY FOR READ
0F1D F0 6C		BEQ	BUFULL	NO - MUST BE A WRITE
0F1F 20 45 0F		JSR	DOREAD	YES - READ BUFFER
0F22 D0 E8		BNE	ADJUST	FIRST NOT USED YET

INPUT ROUTINE - INPUT RETURNED IN A REGISTER

```

OF24 AD 53 A6 CHRIN LDA TECHO READ FROM CASSETTE?
OF27 29 01 AND #$01
OF29 D0 04 BNE FRMBUF INPUT FROM BUFFER
** CHANGE THE FOLLOWING IF OLD INVEC WAS SAVED
OF2B 20 58 8A JSR INTCHR TERMINAL I/O
OF2E 60 RTS WILL RETURN TO $8A21

OF2F 20 CB 0F FRMBUF JSR NXTBUF GET NEXT BUFFER ADDR.
OF32 D0 05 BNE GETIT OK IF NOT AT END
OF34 20 45 0F JSR DOREAD ELSE READ IN FIRST
OF37 B0 EB BCS CHRIN READ ABORTED
OF39 BD 00 0E GETIT LDA BUFFER,X GET BYTE FROM BUFFER
OF3C 2C 53 A6 BIT TECHO CHECK IF ECHO WANTED
OF3F 10 03 BPL GETITR

** CHANGE THE FOLLOWING IF OLD OUTVEC NOT SAVED
OF41 20 46 A6 JSR NUVEC ECHO TO TERMINAL
OF44 60 GETITR RTS WILL RETURN TO $8A21

READ NEXT BUFFER FROM CASSETTE

```

```

OF45 E6 FB DOREAD INC PZCURR BUMP TO NEXT RECORD ID
OF47 A5 FB REREAD LDA PZCURR GET NEXT ID VALUE
OF49 C9 FF CMP #$FF CHECK FOR INVALID ID
OF4B D0 04 BNE DOREAX OK
OF4D A9 01 LDA #$01 ELSE RESET TO 01
OF4F 85 FB STA PZCURR
OF51 8D 4A A6 DOREAX STA P3L PUT IN PARAMETER 3
OF54 20 F3 85 JSR LODCAS LOAD FROM CASSETTE
OF57 90 6E BCC ZERIDX CONTINUE IF LOAD OK
OF59 20 71 81 JSR ERMSG ELSE PRINT ERROR CODE
OF5C C9 8C CMP #$8C MANUAL ABORT? (V1.1 ONLY)
OF5E F0 07 BEQ SETOFF YES - TURN OFF CASSETTE
OF60 20 AF 88 JSR GETKEY WAS FOR KEY FROM HEX PAD
OF63 C9 0D CMP #$0D WAS IT A RETURN?
OF65 D0 E0 BNE REREAD READ AGAIN IF NOT
OF67 38 SETOFF SEC SET THE ERROR FLAG
OF68 A0 FF LDY #$FF Y=-1 TO TURN OFF TAPE
OF6A D0 8E BNE CTURN GO TURN IT OFF

```

OUTPUT ROUTINE - OUTPUT CHARACTER IN A REGISTER

```

OF6C 48 CHRROUT PHA SAVE CHARACTER
OF6D AD 53 A6 LDA TECHO CASSETTE OUTPUT?
OF70 29 02 AND #$02
OF72 F0 12 BEQ DOECHO BRANCH IF NOT CASSETTE
OF74 20 CB 0F JSR NXTBUF GET CASSETTE BUFFER INDEX
OF77 D0 03 BNE STOCHR SKIP IF BUFFER NOT FULL
OF79 20 8B 0F JSR BUFULL EMPTY BUFFER FIRST
OF7C 68 STOCHR PLA RESTORE CHARACTER
OF7D 9D 00 0E STA BUFFER,X PUT INTO BUFFER
OF80 2C 53 A6 BIT TECHO ECHO?
OF83 10 05 BPL NOECHO NO
OF85 48 PHA PUT BACK ON STACK
OF86 68 DOECHO PLA RESTORE CHARACTER
** CHANGE THE FOLLOWING IF OLD OUTVEC NOT SAVED
OF87 20 46 A6 JSR NUVEC OUTPUT VIA OLD OUTVEC
OF8A 60 NOECHO RTS WILL RETURN TO $8A52

```

WRITE OUTPUT BUFFER TO CASSETTE

```

OF8B A9 00 BUFULL LDA #$00
OF8D 8D 4C A6 STA P2L START OF BUFFER IN P2
OF90 A2 0E LDX #$0E
OF92 8E 4D A6 STX P2H
OF95 8E 4B A6 STX P3H AS ENDING PAGE ALSO
OF98 A2 F9 LDX #BUFLN-1 END ADDRESS OF BUFFER

```

First, it is easier to remember a single address instead of half a dozen, and secondly, BASIC requires at least one parameter so it can distinguish a function, so I figured I might as well use it to pass on useful information. Note that the low order of the BASIC calling parameter is passed on the Y register by BASIC. There are six input parameter values to CTURN; 0, 1, -1, 2, -2, and 3.

Four of the input values are rather trivial, and merely involve turning a bit on or off in TECHO. These bits are used to indicate that cassette input or output is active. Bit zero is used to control input mode. If it is on, input characters will be obtained from the cassette [via the buffer]. Off means that input is from the terminal as normal. Bit one of TECHO performs the same function for cassette output mode. Having both bits on at the same time could cause some strange results, since there is only one buffer, and one routine would be putting characters in while the other was taking them out. The input values 1 and 2 correspond to the bit values needed to turn the appropriate mode. I decided for user simplicity to use the negative of the turn-on value to indicate a turn-off request. Note that -1 is \$FF in hex, and by subtracting one we get \$FE, which coincidentally has a zero in just the bit we want to turn off. (Amazing—these computers, aren't they?) The same thing happens to -2 when we subtract one from it.

The other two parameter values of zero and three require some detailed explanation, since they have different meanings depending upon whether you are in the read or the write mode. Normally, the buffer gets filled (or emptied) automatically as it gets used up. PZBIDX is an incrementing pointer that indexes to the last character used in the buffer. The first byte of the buffer area is used to hold the number of bytes in the buffer, including itself. The buffer is considered "used up" when PZBIDX equals this value. Normally, this value would be the number of bytes in the buffer. The problem occurs because a buffer is not necessarily a "logical record."

A buffer is written only when all the characters are used up normally. If my program has done all the writing I want it to do, but hasn't used up an even number of buffers, what do I do with the odd piece of data left in the buffer? Calling CTURN in output mode with a zero value will force a write of this short buffer. When we get around to reading this short buffer back in, there

has to be some way to keep track of how many bytes were used in each buffer. The short buffer may not be the last record on the tape if you decide to add data in a subsequent run of the program. This is why BUFULL transfers the current value of PZBIDX to the start of the buffer before it gets written out. That way, when it gets read back in, the maximum length is set automatically.

In the read mode, we don't have to worry about the last record being short. The write routines took care of that already. There is no end-of-file record or indicator maintained. It is up to the calling program to do that. The problem in the read mode occurs for the read of the first buffer. There are no logical grounds for counting on PZBIDX to point to the end of a buffer the first time I need to get a character. As a matter of fact, it stands a better chance of being zero, since INITIT leaves it that way. Since read is the opposite of write, it makes as little sense to have zero for the read mode indicate the first buffer instead of the last as it does for the write mode. Calling CTURN with an input value of zero in read mode will force a read of the first buffer from the cassette. From then on, read buffers will take care of themselves.

The final input parameter value for CTURN is three. The actual code sets PZBIDX to zero, and sets the maximum buffer value to the length of a buffer. The "logical" meaning of this depends on what you are going to do next. It was originally designed to be used before the first write to the buffer, since the above setting indicates to the write operation that the buffer has nothing in it. In the read mode, the same setting would mean that the buffer was just read in and characters could be removed.

At first, I couldn't think of why anybody would want to set the buffer full for a read without actually doing one, but then... If you write a small amount of data to the buffer [less than one full buffer], you could LOAD another program in and read the data back in by setting PZBIDX back to zero. This would be a way of getting around the fact that a LOAD clears all variables and would allow "passing" data between programs.

CHRIN Handles Character Input

All character input is handled by CHRIN. It never gets called directly by the calling program. The user still calls

0F9A 8E 4A A6	STX	P3L		
0F9D A5 FA	LDA	PZBIDX	GET LAST CHARACTER USED	
0F9F F0 21	BEQ	NWRITE	NO WRITE IF NONE USED	
0FA1 8D 00 0E	STA	BUFFER	PUT AS MAX INDEX	
0FA4 A6 FB	LDX	PZCURR	GET LAST RECORD ID	
0FA6 E8	INX		INCREMENT FOR THIS RECORD	
0FA7 E0 FF	CPX	#\$FF	BE SURE IT IS VALID	
0FA9 D0 02	BNE	BUFULX		
0FAB A9 01	LDA	#\$01	ELSE RESET	
0FAD 86 FB	BUFULX STX	PZCURR		
0FAF 8D 4E A6	STA	P1L	USE FOR AN ID ALSO	
0FB2 AD 30 A6	LDA	TAPDEL	SHORTEN TAPE LEADER	
0FB5 48	PHA		BUT SAVE OLD VALUE	
0FB6 A9 02	LDA	#\$02	NEED SOME TIME TO SPEED UP	
0FB8 8D 30 A6	STA	TAPDEL		
0FBB 20 EA 87	JSR	SAVCAS	MONITOR WRITES CASSETTE	
0FBE 68	PLA		RESTORE LEADER TIME	
0FBF 8D 30 A6	STA	TAPDEL		
0FC2 A9 FA	NWRITE LDA	#\$BUFLEN		
0FC4 8D 00 0E	STA	BUFFER		
0FC7 A2 00	ZERIDX LDX	#\$00	RESET TO BUFFER START	
0FC9 86 FA	STX	PZBIDX	FALL THROUGH TO NXTBUF	
			GET CURRENT BUFFER INDEX AND BUMP FOR NEXT TIME	
0FCB E6 FA	NXTBUF INC	PZBIDX	INCREMENT ID	
0FCD A6 FA	LDX	PZBIDX	USE AS INDEX	
0FCF EC 00 0E	CPX	BUFFER	CHECK IF AT END	
0FD2 60	RTS			
			ROUTINE INITIALIZATION - SET UP ADDRESSES	
0FD3 20 86 8B	INITIT JSR	ACCESS	UNPROTECT SYSTEM RAM	
0FD6 A2 02	LDX	#\$02	SAVE CURRENT OUTVEC	
0FD8 BD 63 A6	ITRANS LDA	OUTVEC-1,X		
0FDB C9 0F	CMP	#\$0F	PAGE ADDRESS OF ROUTINES	
0FDD F0 06	BEQ	NOSAV	ALREADY SAVED, SO SKIP	
0FDF 9D 46 A6	STA	NUVEC,X		
0FE2 CA	DEX			
0FE3 10 F3	BPL	ITRANS		
0FE5 A9 00	NOSAV LDA	#\$00	RESET CURRENT ID TO ZERO	
0FE7 85 FB	STA	PZCURR		
0FE9 A9 0F	LDA	#\$0F	PAGE ADDRESS OF ROUTINES	
0FEB 8D 62 A6	STA	INVEC+01		
0FEE 8D 65 A6	STA	OUTVEC+01		
0FF1 A9 24	LDA	#\$24	ADDRESS OF CHRIN	
0FF3 8D 61 A6	STA	INVEC		
0FF6 A9 6C	LDA	#\$6C	ADDRESS OF CHROUT	
0FF8 8D 64 A6	STA	OUTVEC		
0FFB D0 C5	BNE	NWRITE	SET UP INDECES	
0FFD FF	=	\$\$\$	PATCH AREA	
0FFE FF	=	\$\$\$		
0FFF FF	ZZZEND =	\$\$\$	LAST BYTE OF PROGRAM	

INCHR whenever he wants an input character. INCHR saves the caller's registers and gets to CHRIN via INVEC. Since INCHR has already saved the registers, CHRIN doesn't bother doing it. The first thing that it does do is check the low bit in TECHO to see if cassette input mode is on. If we aren't in cassette mode, the process is to get a character from the terminal by using

INTCHR, and use an RTS to get back to the last part of INCHR, and from there back to the calling program.

When cassette input mode is on, a character has to be obtained from the buffer. PZBIDX is incremented and compared to the end of buffer value by a call to NXTBUF. If there is a character available, it is obtained from the buffer.

In order to provide the capability to echo input as INTCHR would, the ECHO bit (bit 7 of TECHO) is checked. If it is on, the input is echoed to the terminal by way of the old OUTVEC that was saved by INITTT. Either way, return is to INCHR by an RTS, the same as above.

At some point, the buffer has to run out of characters. At this point, we have physically to read another buffer from the cassette. It is really a simple matter of passing the desired FILEID to the SYM monitor and letting it do the work. The FILEID is kept in PZCURR. This value is set to zero by INITTT, and is incremented just prior to each physical read and write. A check is made to make sure it doesn't reach \$FF, since the monitor treats that as a special ID. Zero is also avoided for the same reason. The FILEID is needed in case there is a problem reading the tape and we want to backup and retry the read. After the call to the SYM monitor, the carry is checked to see if the read was successful. If the carry is clear, the read worked, PZBIDX is set to one, a character is obtained, and return is to INCHR, the same as before.

When there is an error (the carry is set), ERMSG is called to let the monitor display the standard ERxx message. Now the problem is to determine what to do about the error. If the error code was \$8C, the load was aborted by the CR key during sync search. This obviously means that the user has given up, so we might as well too. This is done by branching to CTURN with \$FF in the Y register to turn off cassette mode. From then on, characters are obtained from the terminal. For other load errors, the program waits for any character to be entered on the keypad (via a call to GETKEY). At this point, the cassette remote control still is off, but you get a chance to stop it manually before trying again. If you hit any key other than CR, the program loops back and tries to read the same FILEID again. Don't forget to rewind the tape a little before putting it back in play mode. The program will continue to try reading a tape until it gets it right, or you give up.

Caution: aborting the cassette input mode does not stop your BASIC program. In order to stop your BASIC program after aborting the cassette input mode, enter an @ to delete the characters already received from the buffer, and then enter a carriage return. Otherwise, your program will take what it has and probably loop back and turn the cassette input mode back on. Keep cassette input mode on as little as

possible in your program, and double check for syntax errors. Otherwise you may end up feeding data from the buffer to BASIC instead of to your program.

Also note that since these routines are normally called via INCHR, you won't be able to read anything you couldn't enter from the terminal. These routines will handle any bit combination, but INCHR strips parity, and upper cases everything. If you want to be able to write object code or upper and lower case and don't want to reassemble these routines, I would suggest patching out the input character echo (starting at \$F3C), and replacing it with:

```
TAX      Save the input
          character for now
PLA      Discard normal
          return from stack
PLA
TXA      Return input to A
          as expected
JMP $8A3C Go compare to CR
          & return
```

This will bypass the editing normally done by INCHR.

CHROUT Handles Character Output

The basic flow for CHROUT is the same as for CHRIN. Bit two in TECHO is checked instead of bit one, and characters are put into the buffer instead of removed, but the process is mostly the same. BUFULL is called when there is no room to put the current character into the buffer. It can also be called from CTURN to write the last buffer, so it checks to make sure there are actually some used characters in the buffer, since there is no need to write a buffer with nothing in it. A full buffer is always written, but the current value in PZBIDX is moved to the first byte of BUFFER so CHRIN will use it as the maximum buffer length when it gets read in later. The current value of PZCURR is incremented, and that is used as the FILEID for the call to the SYM monitor. Here again the values of \$FF and \$00 are avoided because they would pose problems reading them back in.

Note that the character is output to the terminal via the old OUTVEC value which was saved by INITTT whenever cassette output is not in effect. The amount of tape leader time is changed from the current value to two before the write, and restored after. This is an attempt to save some sync leader time. Depending on how fast your recorder starts and stops, you may want to change this. Zero will never

work, since sync search on a read requires at least ten SYNC's before admitting that things are in sync. I found that a value of one did not allow enough time for my recorder to get up to speed. The value of two is marginally enough, but I am tempted to trade time for safety, and change it to three.

The maximum buffer size is 255 bytes (not 256), of which 254 are for data, and one is reserved for maximum valid buffer length. I chose 250 bytes because it made the end of the program come out about right. The page zero addresses used for PZBIDX and PZCURR are those used by the monitor as RAM input pointers for the EXECUTE command, so don't expect to use it and pick up where you left off. Change the addresses if it bothers you to use monitor locations. I chose to start the buffer at \$E00 for two reasons. First, I don't use the TRIG routines much, especially in the inquiry type programs I planned for these routines. Second, the TRIG routines are self-relocating, so they will fit in front of these easily. Relocate these routines with a little bit of caution. There are a couple of places where parts of addresses are used in load immediate instructions. These have been indicated in the listing. There is no requirement that the programs in buffer occupy adjacent areas. They could be widely separated if that turns out to be convenient.

Reading and Writing Tricks

There are a couple of tricks to writing things out and reading them back into a BASIC program. The main thing is to make your output look as it would if you keyed it in. Don't forget to put commas between items, and remember that strings need quotes around them if they have commas. Probably the hardest part is remembering that BASIC only has a 72-character input buffer. If you create an output line bigger than that and then try to read it back in, you will get beeped and "EXTRA IGNORED". Setting the output line length to 72 or less doesn't help, since all that does is put a carriage return where you don't want it. In case you are interested, the line feeds which BASIC puts out after the carriage return are conveniently ignored by BASIC upon input.

Finally, the 16-bit checksum from \$EFA to \$FFF is \$7C66. This will give you something to check against when you enter the program.

MICRO

EXCERT, INCORPORATED

*** AIM 65 ***

P/N		QTY 1-9
A65-1	AIM-65 w/1K RAM	\$375
A65-4	AIM-65 w/4K RAM	\$420
A65-A	Assembler ROM	\$ 85
A65-B	BASIC ROM	\$100
A65PL	PL/65 ROMS	\$125

ACCESSORIES

P/N		QTY 1-9
Power Supplies (Fully AIM-65 Compatible, Industrial Quality Open Frame)		
2PRS3	+ 5V at 3A, + 24V at 1A w/mtg hardware, cord, etc.	\$ 65
PRS4	+ 5V at 2A, + 24V at .5A w/mtg hardware, cord, etc.	\$ 50
PRS5	+ 5V at 2A, + 24V ± 15% at .5A ± 12V to ± 15V at 4A.	\$ 75

From The Enclosure Group

ENC1	AIM-65 case	\$ 45
ENC1A	AIM-65 case w/space for one expansion board	\$ 49

Cases with Power Supplies

ENC3	ENC1 w/PRS3 mounted inside	\$115
ENC3A	ENC1A w/PRS3 mounted inside	\$119
ENC4	ENC1 w/PRS4 mounted inside	\$100
ENC4A	ENC1A w/PRS4 mounted inside	\$104
ENC5	ENC1 w/PRS5 mounted inside	\$125
ENC5A	ENC1A w/PRS5 mounted inside	\$129

From The Computerist, Inc.

MCP1	Mother Plus™ Dual 44 pin mother card & card cage takes MEB4 VIB1, PTC1, fully buffered, 5 expansion slots underneath the AIM	\$100
MEB4	DRAM Plus™ 16K RAM, 16K Prom sockets, 2-6522 I/O chip and programmer for 5V EPROMS	18K RAM \$295 32K RAM \$395
PTC1	Proto Plus™ Prototype card same size as KIM-1, MEB4, VIB1	\$45
VIB1	Video Plus™ board with 128 char, 128 user char, up to 4K display RAM, light pen and ASCII keyboard interface	\$245
CABLE	For MEB4, VIB1, PTC1	\$ 15

From Optimal Technology

ADC1	A/D eight channels, D/A 2 channels. Requires ± 12V to ± 15V at 100 MA & 2-I/O Ports from AIM-6522	\$115
Cable		\$ 25

P/N		QTY 1-9
SPECIALS		
A65-4AB	AIM-65 w/4K RAM Assembler and BASIC	\$595
A65-4B	AIM-65 w/4K RAM, BASIC	\$510
S/A65-1	AIM-65 w/1K RAM, w/o PRINTER, Display Keybd, User 6522	\$199

From Seawell Marketing, Inc.

MCP2	Little Buffered Mother™ Single 44 pin (KIM-4 style) mother card takes MEB2, PGR2, PTC2 and P102. Has on board 5V regulator for AIM-65, 4 expansion slots. Routes A&E signals to duplicates on sides with 4K RAM	\$199
MEB2	SEA 16™ 16K static RAM board takes 2114L with regulators and address switches	\$280
PGR2	Programmer for 5V EPROMS with ROM firmware, regulators, low force sockets, up to 8 EPROMs simultaneously, can execute after programming	\$299
P102	Parallel I/O board with 4-6522's	\$260
PTC2	Proto/Blank™ Prototype card that fits MCP2	\$ 49
PTC2A	Proto/Pop™ with regulator, decoders, switches	\$ 99

From MTU

DAC3	8 bit DAC Board	\$49
FDC3	Floppy disk controller bd. & DOS, up to four 5 1/4" or 8" drives, double sided, double density	\$595
MCP3	Card file w/4 slot expansion mother bd. w/keybd. brackets	\$ 65
MEB3A	16K DRAM Board, low power	\$298
PI03	24K PROM, 4-8 bit I/O ports w/RS-232 port to 4800 bps. PROM Programmer	\$295
VIB3	8K DRAM Bd. low power w/composite video out in 200 lines 320 dot/line format	\$240

All MTU Software Available for these Products.

Miscellaneous

TPT2	Approved Thermal Paper Tape	\$ 10
	5/165' rolls	\$ 45
MEM6	6/2114 RAM Chips	\$ 40
CAS1	Audio Cassette Recorder	\$ 20
2716	16K5V EPROM	\$ 75
A65-P	Printer	\$ 30
A65-DM	Display Module	\$ 30

All AIM-65 Spare Parts Are Available.

ASSEMBLED & TESTED SYSTEMS

We specialize in assembled and tested systems made from the above items. Normally, the price will be the total of the items, plus \$5 for handling, shipping is extra on all C.O.D.'s or invoiced orders. Please call or write for exact prices or if questions arise. Six month warranty on all systems.

Higher quantities quoted upon request. COD's accepted, shipping will be added. Add \$5 for shipping, insurance and handling on prepaid orders. Minnesota residents add 4% sales tax. Prices subject to change without notice

Mail Check or Money Order To:
EXCERT, INC.
Educational Computer Division
 P.O. BOX 8600
 WHITE BEAR LAKE, MN. 55110
612-426-4114

Multiplying on the 6502

The 6502 processor may not provide for fast multiplication—but here are five routines to speed up multiplication on any 6502 system.

Brooke W. Boering
Vagabond Enterprises
1300 E. Algonquin 3G
Schaumburg, IL 60195

The search for the ultimate multiply routine seems never-ending. For those APPLE owners who have been using the monitor 'MUL' routine in order to get assembly language efficiency, and for others just looking for some fast 6502 multiply code, the following should be of interest.

Fast multiplication has always been very desirable. Over the years, processors have often provided this as a hardware command. Not so, however, on our favorite 6502. The new 16-biters and some hybrid 8-biters now provide it, and execution speed is on the order of 10 to 30 microseconds.

Taking the APPLE 'MUL' routine as a starting point [fig. 1], we can calculate execution speeds based on the number of bits 'on' in the multiplier as follows:

Multi. bits 'on'	Speed
16 (maxi.)	1511 μ s.
8 (aver.)	1223 μ s.
0 (min.)	935 μ s.

In addition to execution time, we must add the overhead of pre-loading or zeroing working bytes and/or registers, and the entry instruction (JSR). This is significant only when such overhead is materially different when comparing alternate techniques. In the case of the

Machine Language Subroutines

MULTIPLYING ON THE 6502
BY BROOKE W. BOERING

ORG \$1000

WORKING BYTES FOR ALL ROUTINES

```
ACL      *      $0050
ACH      *      ACL+01
XTNDL    *      $0052
XTNDH    *      XTNDL+01
AUXL     *      $0054
AUXH     *      AUXL+01
AUX2L    *      AUXL+02
AUX2H    *      AUXH+02
```

Figure 1

APPLE "MUL" ROUTINE

16X16 MULTIPLY

ON ENTRY: MULTIPLICAND IN AUXL, AUXH
MULTIPLIER IN ACL, ACH
XTNDL, XTNDH MUST BE ZERO

A, X, Y NOT SAVED

ON EXIT: 32-BIT RESULT IN XTNDH, XTNDL,
ACH, ACL

```
1000 A0 10      MUL      LDY      #$10      INDEX FOR 16 BITS
1002 A5 50      MUL2     LDA      ACL      ACL * AUX + XTND
1004 4A         LSR      A          TO AC, XTND
1005 90 0C      BCC     MUL4     IF NO CARRY,
1007 18         CLC                     NO PARTIAL PRODUCT
1008 A2 FE      LDX      #$FE
100A B5 54      MUL3     LDA      AUXL,X  ADD MULTIPLICAND
100C 75 56      ADC     AUX2L,X  TO PARTIAL PRODUCT
100E 95 54      STA     AUXL,X
1010 E8         INX
1011 D0 F7      BNE     MUL3
1013 A2 03      MUL4     LDX      #$03
1015 76 50      MUL5     ROR     ACL,X
1017 CA         DEX
1018 10 FB      BPL     MUL5
101A 88         DEY
101B D0 E5      BNE     MUL2
101D 60         RTS
```

(continued)

'MUL' routine, this amounts to an additional 39 microseconds due primarily to the requirements of working byte pre-loading.

An examination of the actual code used in 'MUL' reveals that a very bad tradeoff was taken, which increased execution time by a whopping 70-75%! It did save 2 bytes of code, however. By replacing both internal loops with 'in line' code, this flaw is remedied (fig. 2).

The revised routine cannot be 'stuffed into' the ROM monitor and, therefore, must be executed somewhere in our own code. Once this negative factor is accepted, it is feasible to examine other possible improvements in both speed and convenience.

Fig. 3 shows a repackaging of the revised 'MUL' routine. It has allowed us to incorporate two improvements. First is the removal of some pre-entry overhead by having the caller simply load 2 registers, and completing the storing internally in this new 'MUL16X' routine. Secondly, we have 'frontended' MUL16X to test for a multiplier of 8 bits or less.

The technique of loading registers with arguments rather than requiring the caller to perform the STORE code does not improve overall execution time. Its primary virtues are reduced code in the caller's pre-entry sequences and improved flexibility within the service routine.

The idea of testing for an 8-bit (or less) multiplier is to be able to effect some improvement in execution speed whenever that condition is true. Such a test performed at the start of MUL16X allows for dynamic variation in multiplier length. There are other times, however, when the programmer knows for certain that the multiplier is limited to 8 bits or less. To cover both cases and continue to provide exit conditions common to 'MUL', a new routine, MUL816 is shown in fig. 4.

(continued)

Figure 2

REVISED "MUL" ROUTINE
16X16 MULTIPLY

NOTE: ENTRY & EXIT CONDITIONS SAME AS "MUL"

101E A0 10	RMUL	LDY	#\$10	16-BIT MULTIPLIER
1020 A5 50	RMUL2	LDA	ACL	AC * AUX + XTND
1022 4A		LSR	A	TO AC, XTND
1023 90 0D		BCC	RMUL4	IF NO CARRY
1025 A5 52		LDA	XTNDL	ADD MULTIPLICAND
1027 18		CLC		TO PARTIAL PRODUCT
1028 65 54		ADC	AUXL	
102A 85 52		STA	XTNDL	
102C A5 53		LDA	XTNDH	
102E 65 55		ADC	AUXH	
1030 85 53		STA	XTNDH	
1032 66 53	RMUL4	ROR	XTNDH	SHIFT INTERIM RESULT
1034 66 52		ROR	XTNDL	
1036 66 50		ROR	ACL	
1038 88		DEY		DECREMENT LOOP COUNTER
1039 D0 E5		BNE	RMUL2	
103B 60		RTS		EXIT

MUL 6 X
16X16 MULTIPLY

Figure 3

ON ENTRY: MULTIPLIER IN ACL, ACH
MULTIPLICAND LOW IN Y
MULTIPLICAND HIGH IN X REG.

ON EXIT: 32-BIT RESULT IN XTNDH, XTNDL,
ACH, ACL

103C A5 51	MUL16X	LDA	ACH	8-BIT MULTIPLIER?
103E F0 2F		BEQ	MUL5X	YES, GOTO COMMON
1040 A9 10		LDA	#\$10	SET 16-BIT MULTIPLY
				(FALL THROUGH TO COMMON CODE)
1042 84 54	MULTI	STY	AUXL	SAVE MULTIPLICAND LO
1044 86 55		STX	AUXH	SAVE MULTIPLICAND HI
1046 A8		TAY		MULTIPLIER COUNT TO Y
1047 A9 00		LDA	#\$00	
1049 85 52		STA	XTNDL	ZERO PARTIALS
104B 85 53		STA	XTNDH	
104D A5 50	MUL3X	LDA	ACL	ACL * AUX + XTND
104F 4A		LSR	A	TO AC, XTND
1050 A5 52		LDA	XTNDL	ADD MULTIPLICAND
1052 18		CLC		TO PARTIAL PRODUCT
1053 65 54		ADC	AUXL	
1055 85 52		STA	XTNDL	
1057 A5 53		LDA	XTNDH	
1059 65 55		ADC	AUXH	
105B 85 53		STA	XTNDH	
105D 66 53	MUL4X	ROR	XTNDH	SHIFT INTERIM RESULT
105F 66 52		ROR	XTNDL	
1061 66 51		ROR	ACH	
1063 66 50		ROR	ACL	
1065 88		DEY		DECREMENT COUNT
1066 D0 E5		BNE	MUL3X	LOOP TIL DONE
1068 60		RTS		

Figure 4

M U L 8 1 6
8X16 MULTIPLY

ON ENTRY: MULTIPLICAND LOW IN Y,
MULTIPLICAND HIGH IN X,
MULTIPLIER (8 BITS) IN A REG.

ON EXIT: 24-BIT RESULT IN Y, A, X, AND
XTNDL, ACH, ACL (XTNDH=0)

```

1069 85 50  MUL816 STA  ACL   SAVE MULTIPLIER LO
106B A9 00          LDA  #$00
106D 85 51          STA  ACH   ZERO MULTIPLIER HI
106F A9 08  MUL5X  LDA  #$08   SET 8-BIT MULTIPLY
1071 20 42 10      JSR  MULTI  DO COMMON CODE
    
```

TRANSFER ANSWER FROM HIGH THREE BYTES TO
LOW THREE BYTES AND LOAD EXIT REGISTERS

```

1074 A4 53          LDY  XTNDH
1076 A9 00          LDA  #$00
1078 85 53          STA  XTNDH
107A A5 52          LDA  XTNDL
107C 84 52          STY  XTNDL
107E A6 51          LDX  ACH
1080 85 51          STA  ACH
1082 86 50          STX  ACL
1084 60          RTS
    
```

M U L 8 H I
SPECIAL 8X16 MULTIPLY
8-BIT MULTIPLIER IS HIGH BYTE, NOT LOW

ON ENTRY: MULTIPLICAND LOW IN Y,
MULTIPLICAND HIGH IN X,
8-BIT MULTIPLIER-HIGH IN ACC.

ON EXIT: 24-BIT RESULT IN XTNDH, XTNDL,
ACH, (ACL=0)

```

1085 85 50  MUL8HI STA  ACL   ZERO MULTIPLIER
1087 A9 00          LDA  #$00
1089 85 51          STA  ACH   ZERO MULTIPLIER HIGH
108B A9 08          LDA  #$08   SET 8-BIT MULTIPLIER
108D 4C 42 10      JMP  MULTI  DO COMMON CODE
    
```

(RTS)

M U L 8 X 8
8X8 MULTIPLY

ON ENTRY: MULTIPLICAND IN Y,
MULTIPLIER IN A REG.

ON EXIT: RESULT HIGH IN Y,
RESULT LOW IN A REG.

TIMING: 212 MICROSECONDS MAXIMUM
180 MICROSECONDS MINIMUM
192 MICROSECONDS AVERAGE

MUL816 is entered when the multiplier is known to be 8 bits or less. It provides an execution time improvement on the order of about 37% over the use of the revised 'MUL' routine.

Shown along with MUL816 is a special 'MUL8HI' routine, which is actually an alternate entrance to MUL816 whenever the 8-bit multiplier is known to be the HI order byte of a normally 16-bit multiplication. Its primary virtue lies in combining the efficiency of an 8X16 operation with the same exit protocols of MUL16X, since both must supply 32-bit answers.

By this time it should be obvious that we can improve things even more if we address ourselves to the 8-bit by 8-bit multiply as a separate matter. Note that we are building a 'family' of routines which we can count on to execute at top speed with ease of use.

Fig. 5 shows this last member of our family, MUL8X8. Its features are several. There is no pre-storing to working bytes. Both the preload by caller and the result are register-oriented, since the multiplier and multiplicand are both 8-bit, while the answer is limited to 16 bits. It requires only 25 bytes of code.

The use of MUL8X8, whenever both the values are 8-bit limited, results in a further improvement in execution time of about 50%, when compared to using MUL816. Compared to 'RMUL', the speed increases by some 69% while a whopping 82% improvement is seen over APPLE's 'MUL' routine in its ROM version!

For those interested, the execution times quoted here are based on average 'bits on in the multiplier' of 8 for 16-bit executions and 3 for 8-bit guys. Both maximum and minimum calculations were also performed and changed the percentages only 2% or 3% for comparable multipliers.

Here is a rough breakdown of average execution times:

Routine	16-Bit	8-Bit
'MUL'	1262 μ s	1082 μ s
RMUL	726 μ s	631 μ s
MUL16X	725 μ s	391 μ s
MUL816		393 μ s
MUL8X8		192 μ s

(continued)

(continued)

Figure 5

1090	ANSLO	*	\$0050		
1090	PLIER	*	\$0051		
1090	CAND	*	\$0052		
1090 85 51	MUL8X8	STA	PLIER	SAVE (MULTI)PLIER	
1092 84 52		STY	CAND	SAVE (MULTIPLI)CAND	
1094 A9 00		LDA	#\$00	RA=RESULT HIGH	
1096 A0 08		LDY	#\$08	SET 8-BIT COUNTER	
1098 46 51	MUL1Y	LSR	PLIER	TEST NEXT BIT	
109A 90 03		BCC	MUL2Y	IF OFF, GO ROUND	
109C 18		CLC			
109D 65 52		ADC	CAND	IF ON, ADD	
109F 6A	MUL2Y	ROR	A	SHIFT ANSWER 1 BIT	
10A0 66 50		ROR	ANSLO	*	
10A2 88		DEY		DECREMENT POS. COUNTER	
10A3 D0 F3		BNE	MUL1Y	LOOP UNTIL DONE 8 BITS	
10A5 A8		TAY		Y=RESULT HIGH BYTE	
10A6 A5 50		LDA	ANSLO	A=RESULT LOW BYTE	
10A8 60		RTS			

Summary

Note that although these routines are presented as improvements on the APPLE ROM routine, they are usable on all 6502 systems as they are free-standing.

While 192 microseconds for an 8X8 multiply may not be spectacular compared to 15 or 20 for a hardware command, it should be close to the fastest available on our 1-MHz 6502. For those who don't see any need for this speed, there is at least one chip maker that thinks super fast multiplication will be in high demand. Advanced Micro Devices has a new chip, the AM25S558 [the 'RABBIT'] which attacks an 8X8 multiply in, get this, 45 nsec! Furthermore, the latched version supports cascading 4 of these chips to do 16X16 operations in 100 nsec.

MICRO



MYSTERY HOUSE HI-RES ADVENTURE #1

Your APPLE computer becomes your eyes and ears as you enter a spooky old mansion in search of treasure. You are in complete control as you open cabinets, smash walls etc. Danger is ever present as you find your co-adventurers being murdered one by one. Can you find the killer before the killer finds you?

- OVER A HUNDRED HI-RES PICTURES
- YOUR GAME MAY BE SAVED FOR LATER CONTINUANCE
- RUNS ON BOTH 48K APPLE II AND APPLE II PLUS

Hi-Res Adventure #1 is available now at your local computer store and requires a disk drive. To order directly send \$24.95 to:

On-Line Systems
 36575 Mudge Ranch Road
 Coursegold, CA 93614
 209-683-6858
 VISA, MST CHG, COD, CHECK ACCEPTED

Look for Hi-Res Football coming soon

Find Your Way Around The New Apple® DOS With The Dakin5® Programming Aids 3.3®



Dakin5 Corporation, a Colorado software house, is making available to the public 12 utility programs on one 16 sector diskette, utilizing the new Apple DOS 3.3, which provides 23% more storage.

All of the Dakin5 Programming Aids 3.3 programs are also compatible with the Corvus Disk Drive system.

Features

- Remove REM statements, unreferenced (dead) code, and compress code to increase program speed and save memory and disk space.
- Copy any file or program from one diskette to another. Only the name is needed.
- Print or display a line cross reference and variable name cross reference.
- Print or display all or selected records from a text file.
- Display any sector of a given file or program, and then update any data within that sector, or specify the sector you wish to update, such as directory sectors and sectors occupied by DOS.

- Create, print and modify your own text and Exec files.
- Perform 20-digit arithmetic.
- Copy a diskette without DOS; initialize without DOS; verify source diskette; verify copied data is the same as the original.
- Use a powerful data entry routine that handles both string and numeric data.

Plus Many More Utility Programs for Sophisticated Programmers

Many of these utility programs have been developed and tested for in-house use while producing The Controller™ business package for Apple Computer Inc.

Each programming aids package includes a program diskette and very complete documentation, all attractively packaged in a padded, blue print vinyl 3-hole notebook with silver lettering. An identifying tab separates each program for convenient reference.

See your Apple dealer or contact Dakin5 Corporation, P.O. Box 21187, Denver, Colo. 80221. Telephone: 800-525-0463. VISA or MC welcome.

Apple is a registered trademark of Apple Computer Inc. The Controller is a registered trademark of Dakin5 Corporation.

DAKIN5
CORPORATION

MICRO Club Circuit

Mike Rowe
Club Circuit
P.O. Box 6502
Chelmsford, MA 01824

The following club announcements are presented in zip code order.

PET User Group

New England Computer Society

Meets every third Wednesday at the Mitre Corp. Cafeteria [Rte. 62 at Rte 3, Burlington, MA.]. William C. Ekle is President for approximately 30 members. Address any correspondence to:

19 Winchester Drive
Merrimack, NH 03054

Purpose: "To further the knowledge of the PET and to share information."

New York City Area User's Group

Meets the first Thursday of each month at 7:00 p.m. David Gillette is the president, and the club now has 40 members. For more information, please contact:

Mike Bassman
39-65 52nd St.
Woodside, NY 11377

To enlighten OSI users as to what can be done on an OSI.

APPLE Power Users Group

Meets the second or third Wednesday of every month (7:00 p.m.) at: Syosset High School, Syosset, Long Island, New York. To contact the club concerning membership, library program exchanges, newsletter exchanges, etc., please write to:

Apple Power, c/o M. Lack
8 Division Street
Holtsville, Long Island,
New York 11742

Jim Lyons is the president of our club. Membership is now at 110 and is rapidly expanding. We have a bi-monthly newsletter, "The Pits," which has been a big success. Yearly dues are only \$20 and include a free subscription to our newsletter, computer hardware and software discounts, feature demonstrations and presentations at all meetings and an extensive program library. We now offer 4 different library paks. We welcome new members and encourage information, program and newsletter exchanges with all other Apple users groups.

UAUG

Upstate Apple User Group

Meets on the third Thursday of the month at 7:30 p.m. at the Upstate Computer Shop [629 French Road, Campus Plaza, New Hartford, N.Y.]. Bill Etter is President for this group of 20. Contact Tony Violente, Public Relations at:

629 French Road
Campus Plaza
New Hartford, N.Y. 13413

"Aim to offer support to new Apple owners and support local school projects. Aid in software and hardware problem solution."

Delmarva Computer Club

Meets for a business meeting on the 1st Wednesday of each month and an informal meeting on the 3rd Wednesday of each month, both at 7:30 p.m. Address correspondence to Jean Trafford, Secretary, at:

P.O. Box 36
Wallops Island, VA 23337

"Primary objectives: Aiding the handicapped, bringing computer awareness to the community, providing the opportunity to the community to use and program computers. Non-profit organization — marketing a manual alphabet tutorial program for the PET computer, with all proceeds going to fund club projects."

OSI — MUG

Ohio Scientific Michigan User's Group

This is a recently formed group with a membership of approximately 130 people. They would like to have their presence known to other user groups and to people interested in becoming members. Contact:

Ralph V. Johnson, Sec.
OSI — MUG
3247 Lakewood Avenue
Ann Arbor, MI 48105

SLACC

St. Louis Area Computer Club

Meets on the first Thursday of every month at 7:00 p.m. Membership numbers around 120. Dennis W. Jolly is spokesperson and President. Meetings are held at the Thornhill Branch of the St. Louis County Public Library at Willowick and Fee Fee Road. Contact:

SLACC
P.O. Box 28924
St. Louis, MO 63132

"Promotes the understanding and growth of microcomputing through group activities. We are a processor non-specific club. We are a non-profit registered organization with a monthly newsletter. Meetings are open to the public and membership is not required in order to attend."

OKC Apple User Group

Meets on the first and the third Tuesday of each month at 7:00 p.m. at various computer stores in Oklahoma City area. Andy Gin is the President. Contact:

OKC Apple User Group
Secretary
Greenbriar Digital Resources
P.O. Box 1857
Edmond, OK 73034

"For the benefit of Apple users, owners, and anyone having an interest in personal computing. Member of IAC. Exchange information and ideas, publish 'OKC Apple Times' newsletter, club library, etc."

The APPLE CORPS of Dallas, Texas

The Apple Business and Personal Applications group of the APPLE CORPS meets on the second Saturday of each month at 10:00 a.m. For information on the meeting and place contact:

Bob Matzinger
P.O. Box 13446
Arlington, TX 76013

To develop, review and discuss applications of, and software for the Apple Computer related to business and personal data processing. We are NOT a software exchange group!

APPLE B.U.G. (Bakersfield Users Group)

Meets the first Friday of each month, at 7:30 p.m. For location of meetings, please check with the Computer Warehouse. President is Gary F. Atchison, and membership stands at 25. For more information please contact:

Bob Geisler
20333 Old Town Road
Star Rt. #2
Tehachapi, CA 93561

To enjoy our Apple Computers.

ATARI Computer Enthusiasts (ACE)

Meets every second Wednesday of each month at different members' homes. Stacy Goff is the president and membership totals 20. Address correspondence to:

M.R. Dunn
c/o ACE
3662 Vine Maple
Eugene, OR 97405

To publish newsletter, teach about the ATARI, develop and exchange programs, help in fund-raising for non-profit organizations, aid handicapped members.

MICRO offers a free one year subscription to all clubs registered with us. For registration form write to:

MICRO Club Circuit
Box 6502
Chelmsford, MA 01824

MICRO

Microbes and Updates

Mike Rowe
Microbes & Updates
P.O. Box 6502
Chelmsford, MA 01824

Edward F. Kurtz, Jr. from Northampton, Massachusetts tells us: I have been using the information in the article "Applesoft Floating Point Routines" by R.M. Mottola, MICRO August 1980 [27:53]. In the process I discovered that the subroutine FPDIV2 at \$EA60 does not seem to pay any attention to the sign of the numerator or denominator! I am therefore using only the subroutine FPDIV at \$EA66 for all division operations, and it seems to work properly.

Earl Morris of Midland, Michigan sent this update: I have converted Tiny Pilot (MICRO 16:41) to run on my OSI system. The additions to Tiny Pilot by Bob Applegate (MICRO 27:21) make this an interesting interpreter. However, Applegate's random number function will occasionally return invalid numbers. This is caused by illegal BCD numbers being stored in the seed locations. The 6502 CPU when in the decimal mode cannot handle all combinations of illegal BCD numbers. Consider the decimal addition problem OF + 05. The correct answer [decimal] is 20. However the 6502 cannot carry a "2" into the tens column. The best answer it can give is 1A. This is a correct answer, but not correct BCD format. This answer returned to PILOT will give an invalid number.

Below is the correction to the random function. The "1" is added last instead of first.

Old Code	New Code
SED	SED
SEC	CLC
LDA \$D5	LDA \$D5
ADC \$D8	ADC \$D8
ADC \$D9	ADC \$D9
STA \$D4	ADC #\$01
	STA \$D4

Adding the "1" last gives the CPU opportunity to convert the result into proper BCD format.

C.R. MacCluer of East Lansing, Michigan has some updates to his article, "Satellite Tracking with the AIM 65" which appeared in the August 1980 MICRO (27:13).

The text in the third column of page 13 should read:

```
100 A=7281: E=0: P=103:
      K=99: W=0
300 FOR T=0 TO P
```

And in the listing:

Line No.	Was	Should Be
110	E = 67627	E = .67627
340	- M1):01 -	- M1)(01 -
350	102 - 8	10 - 8
460	THEN 470	THEN 480
	NEXT T	
470		NEXT T
4020	108 - 8	10 - 8

From Shankill, County Dublin, Ireland, Charles H. Putney writes: I read with interest the article in August 1980 MICRO [27:17] by Frank Chipchase on RENUMBER. I prefer a cruder approach of making RENUMBER easier to use. The program listed below creates a text file which when EXEC'ed saves the current program, runs RENUMBER, and restores the program being worked on. Be sure to put RENO on the same diskette as RENUMBER. During a session when RENUMBER is needed just EXEC RENO.

```
PROGRAM: CREATE RENO
10 D$ = " ":REM CNTL D
20 PRINT D$; "OPEN RENO"
30 PRINT D$; "WRITE RENO"
40 PRINT "SAVE RENOFIL"
50 PRINT "NEW"
60 PRINT "RUN RENUMBER"
70 PRINT "N" :REM ANSWER
   TO INSTRUCTIONS
   NEEDED?
80 PRINT "LOAD RENOFIL"
90 PRINT "DELETE
   RENOFIL"
100 PRINT "PRINT"
   ;CHR$(34);"RENUMBER
   LOADED";CHR$(34)
110 PRINT D$;"CLOSE"
120 END
```

Gary M. Ganger of New Carlisle, Ohio caught this error: I would like to point out an error on page 5 of #27. In the description of the front cover the Space War Game was first on the DEC PDP-15, not on a PDP-1. [There never was a PDP-1.]

Pete Cook of Mesa, Arizona writes: A few Microbes have become apparent in the article "Creating Shape Tables, Improved!" [28:7].

1. In figure 3, the zero should have one more dot placed in its center. The dots are so close together that you can't tell the difference on the screen, but the missing dot becomes very noticeable if you plot the character display on a printer. Three bytes in the shape table must be changed. Run the program, end it, then type the following:

```
POKE 20044, 44
POKE 20045, 12
POKE 20046, 4
BSAVE SHAPEFILE NUMERALS,
A20000, L188
```

2. Some applications require the use of a blank shape, such as using the space bar within a different alphabet set. To allow this, change line 3100 to 3102 and add new line 3100:

```
3100 IF PEEK (ADDR - 1) = 0
      THEN POKE ADDR, 0:
      ADDR = ADDR + 1:
      GOTO 3170
```

To make a blank shape, simply type "Q". The program will place a zero in the shape table, followed by a zero end-of-record mark.

3. Line 2460 should read "GOTO 2520" rather than "GOTO 2570". This caused the cursor from the last shape to appear in the next shape, and caused some dots to appear in the upper right corner of the screen.

4. Line 4510 should read "XDRAW" instead of "DRAW". This one requires some explanation. The article states it is possible to erase a plotted point by plotting another point over the top of it. This only works if you use "XDRAW" to draw the shape. As the shape is drawn, the point will be plotted in white the first time and in black the second time, thus erasing it.

Don't forget to save the program again after all the changes have been entered.

MICRO

"COMPUTERS 'R' US"

A CONSUMER COMPUTERS SUBSIDIARY

UNBEATABLE MAIL ORDER DISCOUNTS



apple computer
Authorized Dealer

NEW!
CALL FOR AVAILABILITY AND PRICES.



\$925
FOR 16K

48K
FOR ONLY
\$1049

APPLE II OR APPLE II PLUS

APPLE COMPUTER PERIPHERALS

DISK II DRIVE & CONTROLLER CARD With DOS 3.3. List \$645	629
DISK II DRIVE & CONTROLLER card	485
DISK II DRIVE ONLY	425
GRAPHICS TABLET	665
SILENTYPE PRINTER w/int. card	515
SSM AIO SERIAL/PARALLEL kit	155
SSM AIO assembled & tested	190
SYMTEC LIGHT PEN SYSTEM	215
SYMTEC SUPER SOUND GENERATOR	225
SVA 8 INCH DISK CONTROLLER CARD	335
VERSA WRITER DIGITIZER SYSTEM	215
VIDEX WIDETERM 80 COLUMN CARD	315
VIDEX WIDETERM w/graphics ROM	335
LOBO DISK DRIVE ONLY	385
LOBO DRIVE w/controller card	465
DC HAYES MICROMODEM II	315
DAN PAYMAR lower case kit	55

APPLE COMPUTER INTERFACE CARDS

PARALLEL PRINTER int. card	145
COMMUNICATION CARD w/conn. cable	185
HI-SPEED SERIAL int. card	145
LANGUAGE SYSTEM with PASCAL	425
CENTRONICS PRINTER int. card	185
APPLESOFT II FIRMWARE card	145
INTEGER BASIC FIRMWARE card	145

MOUNTAIN HARDWARE ACCESSORIES

A Division Of Mountain Computer

APPLE CLOCK/CALENDAR card	225
SUPERTALKER 80200 SPEECH SYNTHESIZER SYSTEM	245
ROMPLUS w/keyboard filter	185
INTROUX-10 8BR REMOTE CONTROL SYSTEM	245
INTROUX-10 controller card only	165
ROMWRITER SYSTEM	155
MUSIC SYSTEM (16 voices/stereo)	485
A/D-D/A 18 CHANNELS	319
EXPANSION CHASSIS (8 total)	555

APPLE ADD-ONS

CORVUS 10 MEGABYTE HARD DISK DRIVE SYSTEM w/pwr supply	4395
CORVUS CONSTELLATION	595
16K MEMORY UPGRADE KIT (TRS-80, APPLE II, SORCERER)	80
ABT NUMERIC INPUT KEYPAD (specify old or new kybrd)	115
ALF MUSIC SYNTHESIZER	235
BRIGHTPEN LIGHTPEN	32
GP1B IEEE-488 (1978) int.	259
ARITHMETIC PROCESSOR card	335
SPEECHLINK 2000 (84 Word Vocab.)	215
MAR SUP-R-MOD TV MODULATOR	30
MICROSOFT 2.80 SOFTCARD SYSTEM w/CP/M & MICROSOFT BASIC	299
MICROWORKS-DS-85 DIGISECTOR	339
LAZER lower case adaptor	50
M&R SUPER TERMINAL 80 column card	335

APPLE II or APPLE II PLUS SOFTWARE

PASCAL with LANGUAGE SYSTEM	425
FORTRAN for use with LANGUAGE SYSTEM	185
CP/M for use with MICROSOFT 2.80 SOFTCARD (incl.)	299
DOS 3.3	49
THE CONTROLLER General Business System	519
THE CASHIER Retail Management & Inventory System	199
APPLEWRITER Word Processor	65
APPLEPOST MAILING Ret system	45
APPLEPLOT Graph & Plot System	80
DOW JONES PORTFOLIO EVALUATOR	45
APPLE CONTRIBUTED VOLUMES 1 thru 8 w/manuals	30
VISI-CALC by PERSONAL SOFTWARE	120
DESKTOP/PLAN by DESKTOP COMPUTERS	85
CCA DATA MANAGEMENT SYSTEM by PERSONAL SOFTWARE	85
APPLEBUG ASSEMBLER/DISASSEMBLER	75
APPLE DOS TOOL KIT	65

VIDEO MONITORS

LEEDEX VIDEO 100	129
SANYO 9" B&W	165
SANYO 15" B&W	245
PANACOLOR 10" COLOR	329
NEC 12" HI-RES COLOR	875
NEC 12" LO-RES COLOR	399
NEC 12" GREEN PHOSPHOR(P31)	239

\$129
LEEDEX VIDEO 100

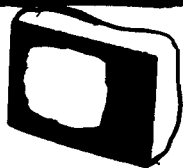
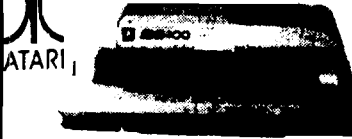
ATARI
16K FOR **\$799**

ATARI 800 PERSONAL COMPUTER SYSTEM

ATARI ACCESSORIES

400 COMPUTER	479
820 PRINTER (40 col)	459
810 DISK DRIVE	559
410 Program Recorder	59
815 DUAL DISK DRIVE	1199
822 THERMAL PRINTER (40 col)	369
825 PRINTER (80 col. imp.)	795
850 INTERFACE MODULE	175
ATARI 16K RAM MODULE	155
LIGHT PEN	65
ACOUSTIC MODEM (CAT)	169
COMPUTER CHESS	35
SPACE INVADERS	19
STAR RAIDERS	49
SUPER BREAKOUT	35
3-D TIC-TAC-TOE	35
VIDEO EASEL	35
MUSIC COMPOSER	49

PRINTERS

ANADEX DP-8000	775
ANADEX DP-9500	1350
BASE 2	599
CENTRONICS 737	825
MPI 88-T	699
PAPER TIGER IDS-440 w/graphics	895
NEC SPINWRITER	2550
TRENDCOM 200	519
SILENTYPE w/int.	515
EPSON TX-80 w/graphics	729
EPSON MX-80 132 col	620



EPSON TX-80



OHIO SCIENTIFIC

\$699
C4P

8K ROM BASIC
8K RAM EXPANDABLE TO 96K
32x64 UPPER & LOWER CASE
256x512 GRAPHICS POINTS
PROGRAMMABLE TONES
ANALOG INPUTS
C4PME (1 DISK DRIVE).....1599

NEW!

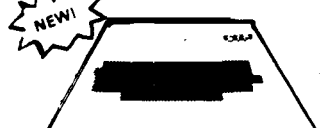

\$429

CIP MOD II
8K ROM BASIC
8K RAM EXPANDABLE TO 32K
COLOR EXPANSION
48 LINE DISPLAY EXPANSION

SOFTWARE

	Cassette	Disk
SPACE INVADERS	19	29
SARGON II	30	35
FORTH	N/A	69
OS 85-D V3.3	N/A	79
MDMS PLANNER	N/A	100
GRAPHICS I	N/A	35
DAC I	N/A	45
ASSEMBLER/EDITOR	40	N/A
EXTENDED MONITOR	20	N/A
PASCAL & FORTRAN (4P & 8P only)		450

When ordering please specify system.

PLOTTERS

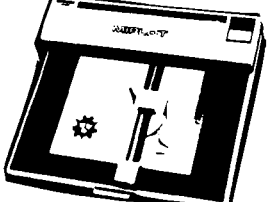

\$1095
only

WATANABE MIPLLOT

for more info please call or write

- FAST DELIVERY
- LOW PRICES
- COURTEOUS SERVICE
- KNOWLEDGEABLE STAFF
- LARGE VARIETY

IN CALIFORNIA, OR FOR BACKORDER OR TECHNICAL INFO CALL:
(714) 698-8088

TOLL FREE ORDER LINE: **1-800-854-6654**

CREDIT CARD USERS PLEASE READ TERMS OF SALE IN ORDERING INFORMATION

ORDERING INFORMATION: Phone Orders Invited using VISA, MASTERCARD, AMERICAN EXPRESS, or bank wire transfers. VISA & MC credit card service charge of 2%. AE credit card service charge of 5%. Mail orders may send charge card number (include expiration date), cashier's check, money order or personal check (allow 10 business days to clear.) Please include a telephone number with all orders. Foreign orders (excluding Military PO's) add 10% for shipping and all funds must be in US dollars. Shipping, handling and insurance in U.S. add 3%. California residents add 6% sales tax. Our low margins prohibit us to send COD or on account. All equipment subject to price change and availability. Equipment is new and complete with manufacturer warranty. We ship most orders within 2 days. Order desk hours are Monday thru Saturday 9-5 PST. Send for FREE 1981 Catalog. WE ARE A MEMBER OF THE BETTER BUSINESS BUREAU AND THE CHAMBER OF COMMERCE. RETAIL STORE PRICES MAY DIFFER FROM MAIL ORDER PRICES. PLEASE SEND ORDERS TO: CONSUMER COMPUTERS MAIL ORDER CRU Division 8314 PARKWAY DRIVE, GROSSMONT SHOPPING CENTER NORTH, LA MESA, CALIFORNIA 92041

SPACE WAR

You're in command in **SPACE WAR!** Destroy your opponent's ship by forcing him to collide with the sun or to explode upon re-entry from hyperspace... or challenge him face-to-face with missile fire. You're in command of the speed and direction of your ship. You control the timing of your missiles. You select the game mode from five options, including Reverse Gravity, and the battle begins. Accelerate to place your shots, and escape into hyperspace before your opponent comes within range. But be wary: he'll shift may circle out of sight and reappear on the opposite side of the galaxy! (This is the classic MIT game re-designed especially for the Apple.)



and SUPER INVASION

- **Super Invasion** is the original invasion game, with the original moon creatures and faster action than any other invasion game.
- Features superb high resolution graphics, nail-biting tension and hilarious antics by the moon creatures!
- Self-running "attract mode" of operation for easy learning and demonstrating of the game.
- As good in every way as the famous Invaders arcade game.
- High speed action! • Sound effects!
- Runs on the Apple II and the Apple II Plus

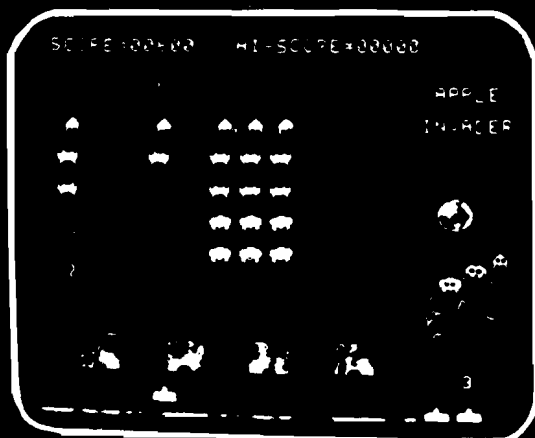

Fifty-five aliens advance and shower you with lethal writhing electric worms. As you pick off the aliens, one-by-one, they quicken their descent. They whiz across the screen wearing away your parapets, your only defense, coming closer and closer to your level. **Super Invasion** is the original invasion game with the original moon creatures and faster action than any other invasion game on the market.

Super Invasion is available for only \$19.95 on cassette (CS-4006) for a 32K Apple II. **Space War** is \$14.95 on cassette (CS-4009) for a 16K Apple II. **Space War** and **Super Invasion** are on one disk (CS-4508) for a 48K Apple II for only \$29.95.

Send payment plus \$1.00 shipping and handling to Creative Computing Software, P.O. Box 789-M, Morristown, NJ 07960. NJ residents add \$1.00 sales tax. Bankcard orders may be called in toll free to 800/631-8112. In NJ call 201/540-0445.

sensational software

creative computing software

MICRO

Software Catalog: XXVII

Name: **Rental Manager**
System: APPLE II or APPLE II+ or Language System
Memory: 48 K
Language: Applesoft
Hardware: APPLE II, Disk II w/2 drives, Printer

Description: A total system for rental property management. It handles accounts receivable, accounts payable and the general ledger. Maintains the chart of accounts and buildings, listings for present and future tenants, and will print reports and notices for "problem tenants." Automatically posts entries between systems and creates back-up copies of information entered. Includes a separate instructional version and full user documentation.

Price: \$695.00
Author: **Bill Tesnow** (a property manager)
Available: **Blue Lakes Computing**
438 N. Frances
Madison, WI 53703

Name: **R & G DATABASE**
System: APPLE II and APPLE II Plus
Language: Applesoft
Hardware: APPLE II with Disk, Optional Line Printer

Description: A keyed random access filing system, providing rapid access to items on file under full user control. The suite of more than five programs is run by explicit questions and simple keyboard responses. This allows even the non-programmer to set up a professional filing system. The report generator works with screen or line printer. Reports are selective and result fields can be generated, as can new headers. Print and screen format are under full control of the user. It prompts the user when he is likely to make a mistake. An unusual feature is the easy to use comprehensive data validation specified by the user and then used by the system for all further file inputs. State Configuration. (No. of Drives etc.)

Price: \$85.00 plus shipping
Includes: Manual and Disc
Author: **John Robinson**
Available: **R & G MICRO's**,
550 Midgeland Rd,
Blackpool, Lancashire,
England

Name: **Restaurant Evaluation**
System: Apple II, Apple Plus
Memory: 16K
Language: Applesoft II
Hardware: Optional: Disk II, printer
Description: Evaluates potential restaurant/nite club sites and thereby reduces the margin of risk involved in purchasing a new or existing business. All the necessary percentages and formulas are programmed to evaluate whether a potential site will be profitable or not. The program is also structured for use by present restaurateurs to evaluate whether or not their present business is operating at cost and profit efficiency. Calculates monthly gross, computes monthly loan notes (or mortgages), and reports weekly, monthly and annual net profit/loss in dollar amounts and percentages. All rights reserved.

Price: \$19.95 + \$2.00 (P&H)
First Class Mail, Check or Money Order.
Available: **Mind Machine, Inc.**
31 Woodhollow Lane
Huntington, N.Y. 11743

Name: **Wind Energy Calculations**
System: Apple II or Apple II Plus
Memory: 16K
Language: Applesoft II
Hardware: Printer optional
Description: This program allows the prospective wind-charger buyer, builder, or experimenter to familiarize himself with the theory behind obtaining power from the wind. Simply input values for various parameters and choose how they are to be incremented for the calculations. Learn what propeller parameters are compatible with any size generator, what effect an increase or decrease in height has on power output, and what to expect from any combination of system size, efficiency, and wind velocity. Parameters that can be calculated include size, RPM, and tip-speed-ratio of propellers, useful watts available, kilowatt-hours per day output, and more.

Price: \$9.50 postpaid on cassette
Available: **Charles O'Neill**
3-C Liberty Lane
Elk City, Okla. 73644

Name: **Hi-Res Shape Encode**
System: Apple II
Memory: 16K
Language: Integer BASIC
Description: This is a 16K Integer BASIC program that uses standard 40X40 graphics to encode several shapes into a Shape Table for display in graphics. The program displays both plot and non-plot moves. After encoding, non-plot moves may be erased. The bytes of each shape are stored in a Shape Table for writing on cassette tape. Shapes are changed by tracing forward or backward along a shape's moves. Text and graphic displays allow moves to be erased, changed, or inserted. The program has options to delete, copy, move, replace, or swap entire shapes in a Shape Table. Documentation includes features, cassette operation, new shapes, reading and writing Shape Tables, modifying shapes and tables, examples, and program structure.

Price: \$7.50, check or money order
Includes: Program and shape table on cassette, documentation
Author: **Harry L. Pruetz**
Available: **MICROSPAN Software**
709 Caldwell St.
Yoakum, TX 77995

Name: **The Aliveness Life Dynamic**
System: Apple II
Memory: 48K
Language: Applesoft, Machine
Hardware: Apple II, Disk II
Description: Adds up to a long and intense look at, and "workshop" on, all the major barriers to *aliveness*. Deals with life-awareness, and increasing the understanding of the interrelationships between feelings, aliveness, rational vs. irrational, neurosis and awareness. Most of the disk centers on three unique games (in Hi-Res with shape tables): *The Primal Oil Fields*, *The Keys to Awareness*, and *Rationality!* You'll love them as games, learn from them as enlightening experiences.

Price: \$15.95
Includes: Disk, game card
Available: **Avant-Garde Creations**
P.O. Box 30161 MCC
Eugene, OR 97403

Name: **Empire of the Stars**
 System: OSI C1P
 Memory: 8K
 Language: 8K Basic-in-ROM
 Hardware: C1P or Superboard
 Description: Grand scale strategic simulation of the rise to power of 1 to 4 interstellar empires. Players wield fleets of up to thousands of ships in an attempt to rule the galaxy. Captured and colonized worlds produce new ships.
 Price: \$9.95
 Author: **Gorple the Rigellian**
 Available: **Horizon Computing**
 P.O. Box 479
 Mendham, NJ 07945

Name: **Diskolog**
 System: APPLE II
 Memory: 48K
 Language: Applesoft
 Hardware: APPLE II, Disk II
 Description: A utility program that will alphabetically catalog a large number of programs. Features include: FIND A DISK —locates disk name by inputting program name or characters in name; CATALOG A DISK —lists all programs on a disk; LIST ALL PROGRAMS —lists all programs on file and indicates disk name; ADD A DISK —adds a new disk to file (using screen read feature); DELETE A DISK —deletes a disk from file; LIST BY TYPE —lists all programs by type (A, B, I, T); RENAME A DISK —changes name of disk in file; and LIST ALL DISKS —lists disks in file and indicates number of sectors remaining.
 Price: \$14.95
 Includes: Disk, Instructions
 Available: **CompuTek**
 28278 Enderly Street
 Canyon Country, CA
 91351

Name: **DATA HANDLER**
 System: APPLE II, APPLE II Plus, PET
 Memory: 7K
 Language: Applesoft, PET BASIC
 Hardware: Floppy disk drive
 Description: A disk oriented data manager software package. Easy data file creation and powerful record handling. User can sort, merge, add, delete, update, view, print, write data files and more. Special features include mass updating and sorting by fields. Code is easily modified. Excellent for office use!
 Price: \$25.00 postpaid
 Includes: Software on floppy disk, documentation, and example applications.
 Author: **Rick Keck**
 Available: **Business Computer Services Co.**
 9020 Eby
 Overland Park, KS 66212

Name: **OPTIMIZED EP-2A SOFTWARE**
 System: Any 6502
 Memory: 1.25K
 Language: Assembly
 Hardware: Standard EP-2A
 Description: Turns the EP-2A into a professional quality EPROM programmer. Five commands are available: ERASE verify, PROGRAM, PROGRAM verify, COPY PROM to RAM, EXIT. Full address prompting is performed; appropriate messages are printed (e.g., PROGRAMMING...). Extensive error checking is performed. Cassettes available for AIM, KIM, and SYM systems; others may load object (or source) from listing provided. Loads at \$0200. Specify system!!!
 Price: \$19.95 Listing and instructions
 \$2.00 Cassette (ASK FAMILY ONLY), \$ 2.00 Custom Assembly
 Author: **Jeff Holtzman**
 Available: **Jeff Holtzman**
 6820 Delmar—203
 St. Louis, MO 63130

Name: **C RAE**
 System: Apple II or Apple Plus
 Memory: 48K
 Language: Applesoft on ROM
 Hardware: 3.2 DOS & Disk
 Description: Co-resident Applesoft Editor for Applesoft programs. Perform global change/finds to most anything in your Applesoft program, quote a range of lines, a stop-list that produces a fault optimized listing, dump, a very fast renumber, APPEND, AUTOLINE Numbering. All commands invoked with one key command and needs to be loaded only once while you are developing and running your program.
 Price: \$14.95 on disk
 Available: **Highlands Computer Services**
 14422 SE 132nd
 Renton, WA 98055

These listings are free. In order to obtain a free listing, however, software producers or distributors must follow the format used here. The description part of the listing may NOT exceed 12 typeset lines.

Listings are published in the order in which they are received. However, only one entry per company is accepted for publication in any single month. When more than one entry is submitted, the company submitting the entry must establish the relative priorities. If the software product or its price change after an entry is submitted, it is the responsibility of the company to notify MICRO prior to publication.

Name: **BrownPak I Diskette**
 System: APPLE II
 Memory: 16K-48K
 Language: Applesoft in ROM
 Hardware: Disk II is preferable
 Description: A diskette of utility routines. Machine language routines include print using, sort, packing and unpacking, data, and a special input command. Applesoft BASIC Routines include auto diskette menu, disk-free utility, Hi-Res shape utilities and a general input routine.
 Price: \$39.95
 Author: **Donald Brown**
 Available: **The Computer Emporium**
 3711 Douglas
 Des Moines, IA 50310

Name: **APARTMENT MANAGER**
 System: APPLE II or APPLE II Plus
 Memory: 48K [Firmware Card if APPLE II]
 Language: Applesoft II and Assembly
 Hardware: 2 Disk Drives, 132 column printer
 Description: Maintains financial and managerial data for up to 6 separate complexes; each complex can contain a maximum of 120 units (user determined). Maintains MTS, YTD rental income for all tenants on file. Calculates security deposit interest. Generates operating statements, and rental totals as well as much more.
 Price: \$325 includes manual
 Author: **Gary E. Haffer**
 Available: **Software Technology for Computers**
 P.O. Box 428
 Belmont, MA 02178

Name: **Video Games 1**
 System: OSI, C2, C4, C8 BASIC-in-ROM
 Memory: 8K
 Language: BASIC
 Hardware: None special
 Description: Video Games 1 consists of three games; Head-On, Tank Battle, Trap! Head-On is an arcade-style game for one. You must try to avoid a head-on crash by changing lanes. Tank Battle is a tank game for two to four players. Trap! is a blockade-style game, with enhancements for one or two. Color and sound for machines so equipped.
 Copies: Just released
 Price: \$15 on cassette tape, ppd.
 Author: **Mike Bassman**
 Available: **Orion Software Associates**
 147 Main Street
 Ossining, N.Y. 10562

OHIO SCIENTIFIC

SUPERBOARD II \$ 279.00
 610 BOARD 8K \$ 279.00
 620 BOARD \$ 99.00
 (OSI BUS FOR 610)
 630 BOARD \$ 225.00
 (ADDS COLOR ETC.)
 C4P series 2 \$ 859.00
 C8P-DF-32K \$2939.00
 AC20 COLOR MONITOR
 10 in.-NOT A TV-\$399.00

VISA, MASTERCARGE-O.K. -

SHIPPING AND INS. CHARGE
ADDED TO CREDIT ORDERS.
CHECKS MUST CLEAR BANK
BEFORE SHIPMENT:NO COD.

E&I TECHNICAL SERVICE
 5300 PARIS GRAVEL RD
 HANNIBAL, MO. 63401
 314-248-0084

OHIO SCIENTIFIC

C2OEM- The Best Buy In 8" Disk Systems

FREE
ATV
MICROVERTER
with

Challenger 1P

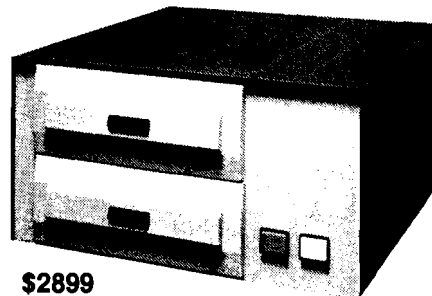

\$2899

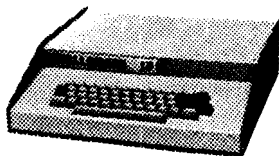

The C2-OEM cabinet can be table top, rack mounted or incorporated in a matching desk which will accommodate a CRT terminal and printer. Industry standard parts provide very reliable operation and easy service. And best of all, the C2-OEM can make use of most of the business application software and accessories for the popular, premium performance Ohio Scientific Challenger III.

COMPUTERSHOP

Boston Union N H Cambridge
 590 Comm. Ave Rte. 16B 288 Norfolk St.
 (across from B.U.) 603-473-2323 (near M.I.T.)
 247-0700 661-2670

SPECIAL INTRODUCTORY OFFER

Programmable Character Generator Board \$89.95

You can use OSI's characters or you can make your own. Imagine you can now do true high resolution graphics 512 x 256 dots in the 64 x 32 screen format. And all under your control!

Other mods available — send for catalog.

SOFTWARE (with Documentation)

PC Chess V1.9 \$14.95

Play Chess against your computer!

Helicopter Pilot: (64 CHR Video Only) \$ 8.95

An Excellent Graphics Program!

Golf Challenger \$14.95

From 1 to 4 players. Play a round of golf on your 18 hole golf course. One of the best programs I have ever seen! You can even design your own course. Comes with full documentation (14 pages).

Two Very Intricate Simulations!

Wild Weasel II: You operate a Sam Missile base during a Nuclear War. Not as easy as you think! You must operate in a three dimensional environment.

Fallsafe II: The shoe is on the other foot! Here you are in the attacking bomber and you must penetrate deep into enemy territory. Can you survive? An extremely complex electronic warfare simulation! SPECIAL: both for 19.95

Hardware: C1P Video Mod: Makes your 600 Video every bit as good as the 4P and 8P. Gives 32/64 CHR/Line with guardbands 1 and 2 Mhz. CPU clock with 300, 600 and 1200 baud for Serial Port. Complete Plans \$19.95

KIT(Hardware and Software) \$39.95

Installed: 32CHR — \$79.95, 64CHR-\$89.95

Extra K of Video RAM for 64CHR not included!

C1P Sound Effects Board: Completely programmable! For the discriminating hobbyist, the best board on the market for creating sound and music. Can be interrupt driven so that you can use it for gaming purposes. Has on board audio amp, 16 bit interval timer, 128 Bytes of RAM and two 8 bit parallel I/O Ports.

Assembled and tested \$89.95 Bare Board \$39.95
 Both Include Prog. Manual and Sample Software.

C1P HI Speed Cassette Kit: Gives a reliable 300, 600, and 1200 Baud. No symmetry adjustments — the ideal fix for OSI's cassette interface. Easily implemented in 30 minutes. Will save you time and money even the first night you use it! \$12.95

Many, many more. Send for Catalog with free program (Hard Copy) and BASIC Memory Map. \$1.00. Two locations to serve you:

Progressive Computing
 3336 Avondale Court, Windsor, Ontario
 Canada, N9E 1X6
 (519) 969-2500

or

3281 Countryside Circle, Pontiac TWP, MI 48057
 (313) 373-0468

VISA

MASTER CHARGE

OHIO SCIENTIFIC'S

In the December issue of the Ohio Scientific Small Systems Journal we are presenting a brief description of the new Vocalizer software and three, user contributed, game programs.

If you are interested in contributing software or other articles to the Small Systems Journal contact:

Small Systems Journal
c/o Ohio Scientific, Inc.
1333 S. Chillicothe Rd.
Aurora, Ohio 44202

Ohio Scientific manufactures two products which support speech synthesis, the CA-14A and CA-15V. The CA-15V is the Universal Telephone Interface which was described in the Small Systems Journal of the June 1980 MICRO. The CA-14A contains virtually the same speech output circuitry but has a non-populated voice input area designed for experimental use.

Both the CA-14A and the CA-15V generate artificial speech with a VOTRAX® speech synthesis module. The VOTRAX speaks words on a phoneme-by-phoneme basis so it is possible to reproduce nearly every word of the English language.

Phonemes can be considered as the basic building blocks of the spoken word. A few of the phonetic codes used by the VOTRAX are:

Phoneme	Typical Usage
TH	three
UH	but
EH	ten
ER	her
U	two
O	note

GREAT PYRAMID

```

10 PRINT:PRINT:PRINT
15 GOTO3010
20 PRINTTAB(16)"HOW MANY LEVELS IN THE PYRAMID":
25 INPUTA:PRINT:PRINT
30 IFA<13THEN50
40 PRINT"THE NUMBER OF LEVELS SPECIFIED EXCEEDS THE DISPLAY"
41 PRINT"CAPABILITIES OF THE VIDEO MONITOR, SORRY.":PRINT
45 GOTO20
50 FORX=1TO32:PRINT:NEXT
55 POKE9770,0
60 DIMA(A,3)
70 FORX=1TOA:A(X,2)=X:NEXT
75 FORX=1TOA:W=W+X:NEXT:GOTO2000
80 REM
90 PRINT"-----WHICH SITE DO YOU WISH TO MOVE A LEVEL FROM?"
100 POKEB,128:C=PEEK(B):IFC<16THEN100
105 IFC=16THEN90
110 IFC=128THENF=1
120 IFC=64THENF=2
130 IFC=32THENF=3
135 FF=PEEK(F)
140 FORX=1TO5:POKEF(F),161:FORY=1TO20:NEXTY:POKEF(F),FF
141 FORY=1TO20:NEXTY,X
142 PRINTSPC(63):PRINT
150 PRINT"-----WHICH SITE DO YOU WISH TO MOVE A LEVEL TO?"
160 POKEB,128:C=PEEK(B):IFC<16THEN160
165 IFC=16THEN90
170 IFC=128THENF=1
180 IFC=64THENF=2
190 IFC=32THENF=3
194 FF=PEEK(F)
195 FORX=1TO5:POKEF(T),161:FORY=1TO20:NEXTY:POKEF(T),FF
196 FORY=1TO20:NEXTY,X
200 IFF=TTHEN1000
210 FORX=1TOA:IFA(X,F)<>0THENF1=X:GOTO230
220 NEXTX:GOTO1000
230 FORX=1TOA:IFA(X,T)<>0THENF1=X:GOTO260
240 T1=X:NEXT
245 REM
250 A(T1,T)=A(F1,F):A(F1,F)=0:GOSUB400:GOSUB300:GOTO80
260 IFA(F1,F)>A(T1,T)THEN1000
270 IFT1-1=0THEN1000
280 T1=T1-1:GOTO245
300 FORX=1TOA:A1=A1+A(X,1):A2=A2+A(X,3):NEXT
310 IFA1<>WANDA2<>WTHENA1=0:A2=0:RETURN
340 POKE9770,64:FORX=1TO16:PRINT:NEXT:PRINTTAB(27)"GAME OVER."
350 FORX=27TO35:PRINTTAB(X)CHR$(135):NEXT
360 PRINT:PRINT:PRINT
370 PRINTTAB(5)"MINIMUM SCORE"TAB(28)". . . . . "TAB(55)INT(2+A-1)
380 PRINT
390 PRINTTAB(5)"YOUR SCORE"TAB(28)". . . . . "TAB(55)0
391 FORX=1TO11:PRINT:NEXT
392 INPUT"DO YOU WANT TO PLAY AGAIN":A$
393 ILEFT$(A$,1)="Y"THENRUN
394 FORX=1TO16:PRINT:NEXT
395 PRINTTAB(26)"OK BYE NOW"
396 FORX=1TO11:PRINT:NEXT
399 RUN"BXEC*
400 E=F(F)-128-64*A:FORX=1TOA:IFPEEK(E)<>32THEN420
410 E=E+64:NEXT
420 E=E-10:FORX=ETOE+20:POKEX,32:NEXT
430 E=F(T)-128-64*A
440 FORX=1TOA:IFPEEK(E)=164THEN460
450 E=E+64:NEXTX
460 E=E-64-A(T1,T)
470 FORX=ETOE+2*A(T1,T):POKEX,164:NEXTX
475 G=0+1
480 RETURN
1000 PRINT"----- ILLEGAL MOVE WISE GUY !!!"
1010 FORX=1TO150:NEXT:PRINTSPC(63):A$:
1020 PRINT:GOTO90
2000 REM
2010 F(1)=54286:F(2)=55007:F(3)=54320
2015 POKEF(1),49:POKEF(2),50:POKEF(3),51
2020 J=F(2)-128
2030 FORX=AT01STEP-1
2040 LL=J-A(X,2)
2050 FORY=LLTOLL+A(X,2)*2:POKEY,164
2051 NEXTY
2060 J=J-64:NEXTX
2070 POKE2073,96
2080 B=57008:POKEB,128
    
```

SMALL SYSTEMS JOURNAL

```

3000 GOT060
3010 PRINTTAB(23)"THE GREAT PYRAMID"
3020 FORX=23T039:PRINTTAB(X)CHR$(135):NEXTX:PRINT:PRINT
3030 FORX=1T023
3040 READA$:B=32-INT(LEN(A$)/2):PRINTTAB(B)A$
3050 NEXT:PRINT
3060 GOT020
4000 DATATHE YEAR IS 1000 B. C.
4010 DATA"YOU ARE IN CHARGE OF OVER 100000 MEN, YOUR JOB"
4020 DATA WAS TO BUILD THE GREAT PYRAMID OF EGYPT.
4030 DATAUNFORTUNATELY YOU BUILT IT ON THE WRONG SITE AND NOW HAVE
4040 DATAONLY ONE YEAR TO MOVE IT TO ONE OF TWO ALTERNATIVE
4050 DATA" SITES. SOUNDS SIMPLE, WELL IT WOULD BE EXCEPT FOR"
4060 DATA" A FEW CATCHES. . .
4070 DATA" FIRST THE PYRAMID HAS BEEN BUILT IN A SERIES OF LEVELS
4080 DATA" EACH OF WHICH MUST BE MOVED AS A SINGLE UNIT. . .
4090 DATA" SECOND EACH LEVEL IS A DIFFERENT SIZE AND BECAUSE OF
5000 DATA" EGYPTIAN LAW A LARGE SECTION OF A PYRAMID MAY NOT
5010 DATA" BE PLACED ON TOP OF A SMALL SECTION. . .
5020 DATA" FINALLY, WHEN MOVING THE PYRAMID ANY LEVELS REMOVED
5030 DATA" CAN ONLY BE SET DOWN ON THE SACRED GROUND OF THE
5040 DATA" THREE SACRED SITES. THAT IS ONE OF THE TWO
5050 DATA" ALTERNATIVE SITES OR THE SITE THE PYRAMID IS PRESENTLY
5060 DATA" ON. LUCKILY YOU GET TO CHOOSE THE NUMBER OF
5070 DATA" LEVELS THAT HAVE BEEN COMPLETED.
5080 DATA" ALSO, THE MAXIMUM HEIGHT FOR A PYRAMID IS 12 LEVELS

```

ROAD RACE

```

5 FORX=1T032:PRINT:NEXT:GOTO1000
10 FORX=1T032:PRINT:NEXT
20 PRINT"CAR #1:"TAB(27)"ROAD RACE"TAB(54)"CAR #2:"
30 PRINT" WINS:"TAB(56)"WINS:"
40 PRINT:PRINT:PRINT
50 PRINT"
60 PRINT"
70 FORX=6T057:PRINTTAB(X)".":NEXT:PRINT" "
80 FORX=5T059:PRINTTAB(X)".":NEXT:PRINT:Y=Y+1:IFY<4THEN80
85 A=7:B=56
90 FORX=AT0B:PRINTTAB(X)".":NEXT:PRINT" "
100 A=A+2:B=B-2:Z=Z+1:IFZ<3THEN90
110 FORX=1T010:PRINT:NEXT
111 FORX=54424T054439:POKEX,32:NEXTX
112 POKEX,32:POKE54374,32:FORX=54365T054370:POKEX,32:NEXTX
113 POKEX,32:POKE54303,32:POKE54304,32
120 P=20*64:FORX=8T018:FORY=0T063
130 C=53248+X*64+Y
140 IFPEEK(C)=32THENPOKEC,161:POKEC+P,161:GOTO160
150 POKEC,32:POKEP+C,32
160 NEXTY:P=P-128:NEXTX
161 FORX=54566T054931STEP64:POKEX,185:NEXT
170 A=54900:B=22:D=54772:E=254:POKEA,B:POKED,E
180 G=57088:POKE2073,96
190 FORX=1T08:READH(X):NEXTX:DATA-64,-63,1,65,64,63,-1,-65
192 FORX=1T010
193 C=INT(RND(WS)*1300+100)+53700:IFPEEK(C)<>32THEN193
195 POKEC,227:POKEC+1,228
196 NEXTX
200 POKEG,B
210 IFPEEK(G)=128THENB=B-1:IFB<16THENB=23
220 IFPEEK(G)=64THENB=B+1:IFB>23THENB=16
230 POKEA,B
240 POKEG,4
250 IFPEEK(G)=4THENE=E-1:IFE<248THENE=255
260 IFPEEK(G)=2THENE=E+1:IFE>255THENE=248
265 IFPEEK(A+H(B-15))=185ANDR=1THEN298
270 POKED,E
275 R=0
280 A=A+H(B-15):IFPEEK(A)=185THENPOKEA-H(B-15),32:GOTO400
290 IFPEEK(A)<>32THENA=A-H(B-15):GOTO298
295 POKEA-H(B-15),32:POKEA,B
298 IFPEEK(D+H(E-247))=185ANDS=1THEN200
299 S=0
300 D=D+H(E-247):IFPEEK(D)=185THENPOKED-H(E-247),32:GOTO500
310 IFPEEK(D)<>32THEND=D-H(E-247):GOTO200
320 POKED-H(E-247),32:POKED,E
360 GOT0200
400 C1=C1+1:A$=STR$(C1):A1=LEN(A$)
405 Q=H(B-15):IFQ=10RQ=65ORQ=-63THENC1=C1-1:R=1:A=A-Q:GOTO200
410 FORX=1T0A1:POKE53510+X.ASC(MID$(A$,X,1)):NEXT
415 A=A+2*(H(B-15))
420 POKEA-Q,32:IFPEEK(A)<>32THENA=A-Q
425 POKEA,B

```

As you would expect, building words with phonetic codes is very versatile. However, it can also be tedious and time consuming. For example, consider the word "did". Its phonetic construction with the VOTRAX is D,I,D. That was pretty simple, but look at the construction of another short word "has"—H,AE,I3,Z. This is a little more difficult to code but still sort of obvious. As the words become longer, the coding becomes much less obvious—"average" AE1,I3,V,R,I2,D,J.

Ohio Scientific has developed two new software packages to help minimize the difficulties associated with phonetic coding. These are Vocalizer I and Vocalizer II.

Both Vocalizer I and Vocalizer II operate by automatic translation of English text into phonetic code. This is accomplished by examining each individual word as it is encountered, dividing the word into utterable phonemes, and finally, speaking each phoneme through the VOTRAX.

The actual division of words is done by a set of 327 different rules. The bulk of these rules is based on the *Naval Algorithm* developed at the U.S. Naval Research Laboratory in Washington, D.C. by Honey S. Elovitz et. al. in 1975. This algorithm results in the correct pronunciation of approximately 90 percent of all words (97 percent of all phonemes) in an average sample of English text. The remaining words typically have single errors which are easily corrected by the listener.

An example of one of the translation rules is that the letter "E", when used as the final letter of a word, is not pronounced if it is preceded by zero or more consonants and one or more vowels. The words "hoe", "parade", "picture", and "bee" illustrate this rule.

OHIO SCIENTIFIC'S

Although the *Naval Algorithm* is obviously quite complex, Ohio Scientific's implementation of it is relatively compact. It requires approximately 4K bytes of memory to store and interpret the rules. The algorithm is also quite fast, translating in less than "real time". This means that a new phoneme is ready before the VOTRAX has finished pronouncing the previous one. This is true even with "older" Ohio Scientific systems operating with a one megahertz CPU clock.

The Vocalizer software can be used either as a phonetic code development tool, or as an actual output "device".

In developmental applications, words or phrases can be presented as input to the system, which responds by outputting the proper phonetic codes in a written form. These phonemes can then be modified or optimized at a later time.

The more common use of the Vocalizer is as an additional standard output for Ohio Scientific BASIC. When used in this fashion, all of BASIC's normal output is translated to phonetic code and spoken by the VOTRAX.

For example, this means that instead of having prompts printed at the terminal, they may instead be spoken. In practice, the normal BASIC line

```
100 PRINT "ENTER THE X
COORDINATE";
```

is changed to

```
100 PRINT #6, CHR$(1),
ENTER THE X
COORDINATE";
```

and the VOTRAX verbally requests the entry of coordinate data.

```
430 IFC1=WSTHEN700
440 GOT0200
500 C2=C2+1: D$=STR$(C2): D1=LEN(D$)
501 Q=H(E-247)
502 IFQ=10RQ=650RQ=-63THENC2=C2-1: S=1: D=D-0: GOT0200
505 FORX=1T0D1: POKE53564+X, ASC(MID$(D$, X, 1)): NEXT
510 D=D+2*(H(E-247))
520 POKED-Q, 32: IFPEEK(D)<>32THEND=D-Q
525 POKED, E
530 IFC2=WSTHEN710
540 GOT0200
700 W$="CAR #1 WINS": GOT0720
710 W$="CAR #2 WINS"
720 FORX=1T011: POKE54169+X, ASC(MID$(W$, X, 1)): NEXT
730 W$="TYPE <1> TO CONTINUE <2> TO STOP"
740 FORX=1T034: POKE54221, ASC(MID$(W$, X, X)): NEXT
745 POKE57088, 128
750 G=PEEK(57088): IFG=128THEN900
760 IFG=64THENRUN"BEXEC"
770 GOT0750
800 FORX=1T018: PRINT: NEXT: PRINTTAB(27)"Road Race"
805 FORX=27T035: PRINTTAB(X)CHR$(145): NEXT: PRINT: PRINT
810 PRINT "THE OBJECT OF THE GAME IS TO COMPLETE N NUMBER OF"
815 PRINT "LAPS OF THE TRACK BEFORE YOUR OPPONENT."
916 PRINT "N IS SPECIFIED BY THE USER."
820 PRINT: PRINT "THE PLAYER ON THE LEFT CONTROLS THIS: ";
821 POKE55105+POS(0), 22: PRINT
825 PRINT "THE PLAYER ON THE LEFT CONTROLS THIS: ";
826 POKE55105+POS(0), 254: PRINT
830 PRINT: PRINT: PRINT
835 PRINT "TO CONTROL THE "; POKE55105+POS(0), 22: PRINT
840 PRINT "***** <S> ----- TO TURN COUNTER CLOCKWISE"
845 PRINT "***** <D> ----- TO TURN CLOCKWISE"
850 PRINT: PRINT
855 PRINT "TO CONTROL THE "; POKE55105+POS(0), 254: PRINT
860 PRINT "***** <N> ----- TO TURN COUNTER CLOCKWISE"
865 PRINT "***** <,> ----- TO TURN CLOCKWISE"
870 FORX=1T05: PRINT: NEXT
875 WS=INT(W$)
880 INPUT "HOW MANY LAPS ARE REQUIRED TO WIN THE RACE": WS
885 WS=INT(WS+ .5)
890 GOT010
900 IFC1>C2THENW1=W1+1: GOT0910
905 W2=W2+1
910 REM
915 A$=RIGHT$(STR$(W1), 1): D$=RIGHT$(STR$(W2), 1)
920 C1=ASC(A$): C2=ASC(D$)
925 POKE53576, C1: POKE53630, C2
930 C1=0: C2=0: RESTORE, POKEA, 32: POKED, 32
935 FORX=54169T054181: POKE54181, 32: NEXT
936 FORX=1T03: POKE53564+X, 32: POKE53510+X, 32: NEXT
940 FORX=54221T054256: POKE54256, 32: NEXT: IFW1=50R2=5THEN950
945 GOT0170
950 FORX=1T032: PRINT: NEXT
955 PRINT "CAR #1 SCORED "W1" WINS "
960 PRINT "CAR #2 SCORED "W2" WINS "
965 FORX=1T012: PRINT: NEXT
970 PRINT "HIT <1> TO PLAY AGAIN OR <2> TO STOP"
980 PRINT "FOLLOW YOUR ANSWER WITH A <RETURN>": INPUTA$
990 IFA$="1"THENRUN
995 RUN"BEXEC"
1000 INPUT "DO YOU NEED THE INSTRUCTIONS (Y/N)": A$
1005 IFLEFT$(A$, 1)="Y"THEN800
1010 GOT0970
```

CONCENTRATION 2

```
1 DIMPL$(2): FORX=1T032: PRINT: NEXT
2 FORX=1T02: PRINT "PLAYER # "X" ENTER NAME FOLLOWED BY <RETURN>";
3 INPUTA$: A$=LEFT$(A$, 6): PL$(X)=A$
4 NEXTX: FORX=1T05: PRINT: NEXT
7 DIMA(7), C(8, 8), F(2), L(2), O(2), P(8, 8), R(2), S(7), T(4), U(9), W(2), D$(3)
10 B$=CHR$(161)+CHR$(161)+CHR$(161)+" " : A=48: POKE2073, 96
20 FORX=1T04: C$=C$+B$: NEXTX: FORX=1T03: PRINT " " +C$: NEXTY
50 FORY=1T03: PRINT " " +C$: NEXTY: NEXTX
60 PRINT: PRINT
65 FORT=1T09: READU(1): NEXTT: DATA1, -63, -64, -65, -1, 65, 64, 63, 8
66 FORX=1T07: READS(X): NEXTX: DATA120, 64, 32, 16, 8, 4, 2
70 FORX=53379T053402: POKE53402, 187: POKE53402, 187: NEXT
82 G=53666: FORY=1T010: READA$
84 FORX=1T0LEN(A$): POKE53402, ASC(MID$(A$, X, 1)): NEXTX: G=G+64: NEXTY
```

SMALL SYSTEMS JOURNAL

```
90 DATA THE OBJECT OF GAME IS TO GET THE MOST PAIRS
91 DATA THIS IS DONE BY CHOOSING TWO CARDS. IF THEY
92 DATA MATCH THEN YOU GET 1 POINT AND ANOTHER GUESS
93 DATA GUESS THE NUMBER FIRST , THEN GUESS THE LETTER
94 DATA GAME ENDS WHEN ALL PAIRS HAVE BEEN FOUND.
100 FORX=53378T055006STEP64: POKEK, 187: POKEK+25, 187: NEXTX
130 FORX=53505T054913STEP192: A=A+1: POKEK, A: NEXT
140 FORX=55044T055067STEP3: POKEK, A+9: A=A+1: NEXT
160 FORX=1T08: READQ: FORY=1T08: P(X, Y)=Q: Q=Q+3: NEXTY: Q=0: NEXTX
180 FORX=1T08: FORY=1T08STEP2
190 Q=INT(RND(5)*255+1): C(X, Y)=Q: C(X, Y+1)=Q: NEXTY: NEXTX
220 FORX=1T075: FORA=1T04: A(A)=INT(RND(9)*8+1): NEXTA
230 A=C(A(1), A(2)): B=C(A(3), A(4)): C(A(1), A(2))=B: C(A(3), A(4))=A
241 NEXTX: G=54306
242 FORJ=GT054331: POKEJ, 145: POKEJ+128, 144: POKEJ+320, 144: NEXTJ
243 FORJ=GT054626STEP64: POKEJ, 147: POKEJ+8, 149: POKEJ+25, 146: NEXTJ
244 POKE54373, 78: POKE54374, 65: POKE54375, 77: POKE54376, 69
245 FORX=GT054626STEP64: POKEK+17, 149: NEXTX: GOT0700
260 H=57088
270 FORI=1T02
300 FORM=1T02: A=0: B=0
301 POKE9770, 0
302 PRINT"-----"PL$(I)" CHOOSE NUMBER FOR CARD #"M
310 POKEH, 128
320 FORO=1T07: IFPEEK(H)=S(O) THENA=0: GOT0340
325 NEXTO
330 POKEH, 64: IFPEEK(H)=128 THENA=8: GOT0340
335 GOT0310
340 PRINT"-----"PL$(I)" CHOOSE LETTER FOR CARD #"M
341 POKEH, 2: IFPEEK(H)=64 THENB=1: GOT0380
345 POKEH, 8: IFPEEK(H)=64 THENB=4: GOT0380
350 IFPEEK(H)=32 THENB=6: GOT0380
355 IFPEEK(H)=16 THENB=7: GOT0380
360 IFPEEK(H)=8 THENB=8: GOT0380
361 POKEH, 4: IFPEEK(H)=64 THENB=3: GOT0380
362 IFPEEK(H)=16 THENB=2: GOT0380
365 POKEH, 16: IFPEEK(H)=64 THENB=5: GOT0380
370 GOT0341
380 FORX=54050T054079: POKEK, 32: NEXT
400 F(M)=PEEK(P(A, B))
410 IFPEEK(P(A, B))=187 THEN750
500 FORX=1T09: POKEP(A, B)+U(X), C(A, B): NEXTX
505 L(M)=C(A, B)
510 IFA=A1ANDB=81 THEN750
515 FORK=1T01000: NEXTK
523 A1=A: B1=B
525 R(M)=P(A, B)
526 A=0: B=0
527 PRINTSPC(60): PRINT
528 FORX=1T0100: NEXTX
530 NEXTM
532 PRINTSPC(60): PRINT
534 A1=0: B1=0
539 IFL(1)=L(2) THEN600
565 FORX=1T02: FORY=1T09
570 POKEX(X)+U(Y), F(X)
575 NEXTY: NEXTX
590 NEXTI
595 GOT0270
600 S(B)=S(B)+1
610 FORX=1T02: FORY=1T09: POKEX(X)+U(Y), 187: NEXTY: NEXTX
620 P=P+1
625 O(I)=O(I)+1
627 G=54572
630 FORX=1T02: A$=STR$(O(X)): FORY=1T0LEN(A$)
635 POKEG+Y, ASC(MID$(A$, Y, 1))
640 NEXTY: G=G+9: NEXTX
650 IFF(32 THEN300
660 POKE9770, 64
690 RUN"BEEXEC"
700 G=54379: FORX=1T02: FORY=1T0LEN(PL$(X))
701 POKEG+Y, ASC(MID$(PL$(X), Y, 1)): NEXTY: G=G+9: NEXTX
705 G=54564: D$="SCORE": FORY=1T05: POKEG+Y, ASC(MID$(D$, Y, 1)): NEXTY
720 G=53666: FORY=1T010: FORX=1T027: POKEG+X, 32: NEXTX: G=G+64: NEXTY
730 GOT0260
750 FORX=1T032: PRINT"-": FORY=1T020: NEXTY, X
752 PRINT" ILLEGAL CHOICE --* TRY AGAIN
755 FORX=1T02000: NEXTX
756 FORX=1T060: PRINT" ": FORY=1T025: NEXTY, X: PRINTZ$:
757 PRINT
760 GOT0302
1000 DATA53508, 53700, 53892, 54084, 54276, 54468, 54660, 54852
```

Obviously, since the PRINT statement is used, information and data may be used for speaking results as well as prompting for input.

Vocalizer II software has an additional feature: it can search files for vocabulary matches, as well as generating speech via the *Naval Algorithm*. Also, the user may add special words and abbreviations to the disk-based dictionary.

An example of this is the BASIC reserved word REM. When REM is encountered by Vocalizer II, it is automatically pronounced as "remark". Clearly, this could not be done if only translation by the rules were employed.

The Vocalizer software systems are an extremely important addition to the Ohio Scientific software catalog. For computers that require speech output facilities, the Vocalizer is nearly indispensable.

Vocalizer I is available under OS-65D V3.2 and OS-65U Level I. Vocalizer II is available for both LEVEL I and LEVEL III OS-65U.

BASIC Games

BASIC game programs have always been popular in the Small Systems Journal. This month we are including three contributed games:

Great Pyramid
Road Race
Concentration 2

All of the games include their own instructions.

Two of the three games are two-player games. Great Pyramid is a single player game similar to the classic Towers of Hanoi puzzle.

All of the games operate under OS-65D V3 on 4P and 8P disk-based systems.

For use--



HI-RES GRAPHICS FOR THE APPLE II

PADDLE-GRAPHICS/TABLET GRAPHICS

The most powerful graphic development system available. Upper/lower case text may be drawn in any size, direction or color. Pictures may be sketched and filled in with any of 21 HI-RES colors (must be seen to believe!!) A shape may be constructed automatically from any object appearing on the HI-RES screen.

Paddle-graphics is for use with the standard game paddles distributed with your APPLE and TABLET-GRAPHICS is for use with APPLES' GRAPHICS TABLET.

Paddle and Tablet-Graphics are available now at your local computer store and require 48K Applesoft in rom and a disk drive. To order directly send \$39.95 for Paddle-Graphics or \$49.95 for Tablet-Graphics to:

On-Line Systems
36575 Mudge Ranch Road
Coarsegold, CA 93614
209-683-6858
VISA, MST CIG, COD, CHECK ACCEPTED

Look for Hi-Res Football coming soon

SOFTWARE FOR OS!

Video Games 1.....\$15.
Three games. Head-On is like the popular arcade game. Tank Battle is a tank game for two to four. Trap! is an enhanced blockade style game.

Video Games 2.....\$15.
Three games. Gremlin Hunt is an arcade-style game for one to three. Gunfight is a duel of mobile artillery. Indy is a race game for one or two.

Adventure: Marooned in Space.....\$12.
An adventure that runs in 8K! Save your ship and yourself from destruction.

Dungeon Chase.....\$10.
A real-time video game where you explore a twenty level dungeon.

Board Games 1.....\$15.
Two games. Mini-gomoku is a machine language version of five stones gomoku. Cubic is a 3-D tic-tac-toe game. Both with graphics.

Disassembler.....\$12.
Use this to look at the ROMs in your machine to see what makes BASIC tick. Reconstruct the assembler source code of machine language programs to understand how they work. OUR disassembler outputs unique suffixes which identify the addressing mode being used, no other program has this!

Super! Biorhythms.....\$15.
A sophisticated biorhythm program with many unique features.

C1 Sherhand.....\$12.
Use only two keys to enter any one of the BASIC commands or keywords. Saves much typing when entering programs. Written in machine language.

For all BASIC-in-ROM systems. Selected programs available on disk. Color and sound on video games.

Send for free catalog listing many more programs.

Orlon Software Associates
147 Main Street
Ossining, NY 10562

BAP\$ SOFTWARE 8K Programs for OSI C2/4

1980 INCOME TAX ESTIMATES (1040). Tax tables written into program. Just input the figures and program displays taxes due or refund. Even computes carry-forward cap. gains or losses. Excellent year-round spot-check tax program. **\$19 95**

STOCK CHARTING. Let your computer draw your charts. Displays daily highs, lows, closes and volume. **\$15 95**

PERSONAL FINANCE PACKAGE. 4 programs — tax info. file, budgeting, mileage and current income/payables. **\$17 95**

UNDERSTANDING FINANCIAL STATEMENTS. Four 8-K programs. Great tutorial for intro. to financial statements. **\$24 95**

Add \$1.50 for shipping. Add \$4 for disk.

BAP\$ SOFTWARE

6221 Richmond Ave; Suite 220
Houston, Tx. 77057

WP-6502

a very fine word processor

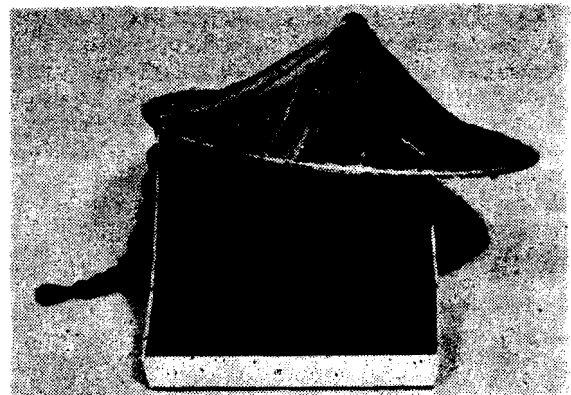

for **OHIO SCIENTIFIC**

Tape (C1,C2,C4)\$75
5" Disk (C1,C2,C4) ...\$75
8" Disk for 650\$75

8" 650 & 65U \$125
Descriptive
Brochure **FREE**



Dwo Quong Fok Lok Sow
23 East 20th Street
New York City, New York 10003
(212)685-2188



MICRO

Up from the Basements

By Jeffery Beamsley

One of the unique features of Ohio Scientific 6502-based computers is the bus (or mother board) used to interface the various boards that make up the system. Many of my customers and dealers have asked me from time to time why they don't see more independent vendors providing compatible hardware for Ohio Scientific systems. The bus, its history, and its features may give us the answer to those and other interesting questions.

The 48-pin Ohio Scientific bus is really a model of efficiency. It is made up of four 12-pin Molex-type connectors. Of these 48 pins, only 42 are defined, leaving 6 available for future expansion. The defined pins on the bus include 20 address lines, 6 power lines, 8 data lines, and 8 control lines. The bus supports distributed, fully-regulated DC power. The placement of the power lines causes dead shorts on the bus for any board improperly inserted. The Ohio Scientific bus was one of the first microprocessor busses to support bi-directional data lines. It is passively terminated and probably has a bandwidth of 5 MHz. It is very inexpensive as far as bus structures are concerned and is classed by Ohio Scientific as proprietary.

The bus arrived very early in Ohio Scientific's growth, about four years ago. It was probably laid out by Mike Cheiky, vice president and motive force behind Ohio Scientific, and it is indicative of much of his thinking at that time. Molex connectors are cheap and don't use gold. They also make both the mother board and system boards somewhat easier to manufacture. There may have even been some thought about compatibility with Southwest Tech, which at that time, with its 6800-based micro, was a real contender for dominance in the microcomputer marketplace. The actual placement of signals on the bus

may have been originally intended to facilitate the construction of the 420 memory board that Ohio Scientific was making at the same time. There is no other logical reason for why the address lines are so jumbled on the bus.

In a classic case of shortsightedness, the 420 memory board was designed to be as single-sided as possible and use no sockets as a cost-saving factor. This meant that the signal paths to the 2102 memories used on the board all had to occur on the foil side of the board, to permit easy desoldering of the IC's. This understandably put some rather severe restrictions on the layout of the address lines. So, if you can't design the memory board to fit the bus, why not design the bus to fit the memory board? I've always felt that foresight is a function of circumstance much more than good planning, anyway.

The circumstance Ohio Scientific found itself in, with the wane of Southwest Tech, was that it was the only "non-standard" manufacturer in an S-100 world. Rather than fold against the competition, Ohio Scientific made the sort of marketing decisions that has made it the force in the marketplace that it is today. The company decided to sell completely assembled and tested systems at a price competitive with what a hobbyist would have to pay to assemble one from various S-100 kit vendors.

As the first company to enter the microcomputer system market, Ohio Scientific turned its lack of S-100 compatibility into a marketing advantage by creating a captive market of system users completely reliant on Ohio Scientific for products. This choice, though, forced Ohio Scientific into a position where it was required to provide this market of users and dealers—in order to retain their interest—with at least the same variety of machines and accessories that were available to the S-100 user. One of the results, four years later, is a company—the only company—that covers the entire spectrum of microcomputers, from the very low-cost personal machines through the multi-user, hard disk-based computers.

Ohio Scientific is understandably protective of the captive, profitable market it has created. Because the bus is not copyrighted, second source vendors have made attempts to market Ohio Scientific compatible products. Those efforts, though, have met with

considerable resistance from the "factory." It is certainly within a manufacturer's rights to be concerned about the effect of "foreign" boards in its systems. Ohio Scientific, however, seems to take its concern well beyond that of well-intentioned warnings to its users.

If nothing else, the S-100 world, with all of its shady vendors, has certainly proven the ability of the marketplace to sort out the quality manufacturers. Ohio Scientific has taken the contrary position of being the sole "authorized" source for bus-compatible products for its systems. This sort of position puts considerable pressure on Ohio Scientific to compete at least functionally with the rest of the microcomputer marketplace. The results of such pressure in some cases are features that compare favorably in print, but not in action. This is also why some Ohio Scientific products are not available for up to six months after they are announced in advertisements. It is very difficult for any single company to compete successfully in all facets and at all levels of the microcomputer market.

This brings us to the conclusion: Ohio Scientific is a market-oriented company. It will do whatever is necessary to sell its product and maximize its profit. That isn't necessarily bad. Ohio Scientific has consistently exhibited a remarkable ability to respond to what the marketplace demands. Unfortunately, that same attitude also leads the company to attempt to protect its captive market with whatever means are at its disposal.

Although this may be a shortsighted attitude and second-source vendors may, in the long run, take some of the pressures off Ohio Scientific to remain competitive in all areas of microcomputing, there are no indications that Ohio Scientific is going to change its attitude towards those vendors. Partially as a result of that attitude, there is currently a lack of strong second sources for Ohio Scientific hardware. With the increased visibility and vitality of the Ohio Scientific user community, I don't think this weakness in the marketplace will continue for long.

MICRO

HI-RES FOOTBALL

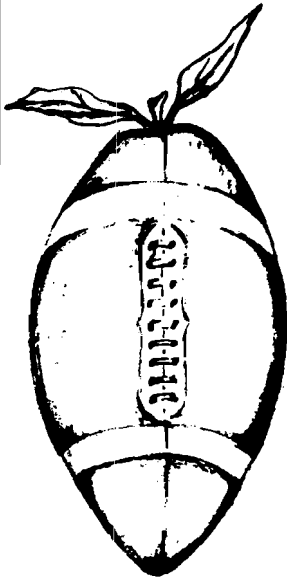

The **ONLY** real-time action football for the **APPLE** computer. Play a friend or play against the computer. Either way you and your opponent call the plays and control the players movement; both passing and running. The field and all men are shown in full **HI-RES** graphics. Real time control is yours both on offense and defense. Fast machine language execution provides realistic action!

48K Apple or Apple Plus \$39.95

See it at your dealer, or call

ON-LINE SYSTEMS

36575 Mudge Ranch Road
Coarsegold, CA 93614 • (209) 683-6858

BASIC THAT SCREAMS

Is the sedate pace of your OSI BASIC taking the fun out of your programming?

Then turn your system on to FBASIC.

Now you can compile your programs with FBASIC and take full advantage of your computers potential.

FBASIC is fast. Not just 5 or 10 times as fast as OSI BASIC. FBASIC is **OVER ONE-HUNDRED TIMES FASTER!** Allowing you to do unheard of things in BASIC. Things that used to require assembly-language. With no need to learn a new language.

The secret to this incredible speed is that FBASIC produces native 6502 machine code. With no run-time interpreter to get in the way of all-out machine performance.

FBASIC is good for any application from wordprocessors to video games. Whatever tickles your fancy. FBASIC accepts standard BASIC source files, and produces executable disk-based object files. It includes many of the features you have always wanted: hex constants, convenient machine language calls, optional user selection of array locations, and more.

As an example of its power and performance; FBASIC was first written in OSI BASIC, which took 6 hours to compile itself. With many features added since then, it now compiles itself in a little over 4 minutes!

So let that pent-up performance out. Find out what your machine is really capable of. Feed it some FBASIC and stand back!

FBASIC runs under OS-65D and requires 48K.

Available on 8" diskette for \$150.

Please include \$5 for shipping & handling.

PEGASUS SOFTWARE

P.O. Box 10074, Dept. M-2,
Honolulu, Hawaii 96816

EROM #1

Requires Applesoft Rom and Romplus.

CRAE's powerful Global Change/Find, optimized List Command, Hex to Decimal and Decimal to Hex conversion now available on a 2716 EPROM.

EROM #1 w/manual

\$69.95

EROM #2

Requires Applesoft Rom and Romplus.

CRAE's Autoline numbering, formatted Memory Dump, Append, number conversion (Hex/Dec) on one 2716 EPROM.

EROM #2 w/manual

\$49.95

EROM #3

CRAE's powerful renumber and quote function now on two 2716 EPROMS.

EROM #3 w/manual

\$49.95

EROM 1, 2, 3...

\$149.95



SEE YOUR LOCAL DEALER OR SEND CHECKS TO
HIGHLANDS COMPUTER SERVICES



14422 S.E. 132nd
Renton, Washington 98055
(206) 228-6691



Washington residents add 5.3% sales tax. Applesoft and Apple are registered trademarks of Apple Computers, Inc.



Romplus is a registered trademark of Mountain Computers, Inc.

Dr. William R. Dial
438 Roslyn Avenue
Akron, OH 44320

- 744. Recreational Computing 8, No. 6, Issue 45 (May/June 1980)**
Lindsay, Len, "Home Video Displays," pgs. 36-37.
General discussion of video displays.
- 745. The Seed 2, No. 5 (May 1980)**
Taylor, Terry N. "New Programs," pg. 9-11.
The Seed librarian lists 429 new programs entered into the club library of Apple programs.
Anon, "International APPLE Core," pg. 12.
New policies of the IAC developed at the recent meeting of the IAC. Dues, access to THE SOURCE, etc.
- 746. SES Newsletter, Issue 18 (May 1980)**
Abbott, J.H., "Animated Sphere Rotation," pgs. 7-8.
This is a very nice hi-res graphics program for the APPLE.
- 747. Rubber APPLE Users Group 3, No. 5 (May 1980)**
Gabelman, Ken, "ONERR GOTO," pgs. 5-6.
A discussion of errors and their management, on the APPLE.
Gabelman, Ken, "Disk Structures," pgs. 7-9.
APPLE data structures, binary and Basic, are discussed.
- 748. APPLE Bits 2, No. 5 (May 1980)**
Sanders, Dwight, "Practical Programs - and Maybe Some that Aren't," pg. 4.
Listings for APPLE Screen Editor, both Tape and Disk versions.
Martie, Ed, "Synergistic Operating Systems," pgs. 9-10.
Some notes on converting a Basic program into Pascal on the APPLE.
Goulder, Al, "Stop Watch and Lap Timer," pg. 11.
Here is a stop watch that is a little different.
Townsend, Jeff, "Helpful Hardware Hints," pgs. 13-14.
Interfacing the APPLE to read eight or sixteen switches. With hardware directions, basic and machine language listings.
Martie, Ed, "Interfacing an External Terminal to the APPLE for use with PASCAL," pg. 15.
Discussion and PASCAL software for using the Heath H-19 Terminal with the APPLE.
Anon, "IAC Application Notes," pg. 24-29.
A number of Application Notes from the International APPLE Core including: Append fix in DOS 3.2; Applesoft HIRES Routines in Applesoft ROM; Literal Input which permits you to enter commas, etc. into Applesoft print statements; Stalking the Wild Left Bracket-and reverse bracket, underline, etc.; also a list of 61 known PASCAL Problems.
- 749. Softside: Apple Edition 1, Issue 5 (May, 1980)**
Wolfson, Mark J., "The Small Marquee," pg. 10-13.
Learn to spell without vowels, on the Apple.
Mauch, John, "Hyperboloid," pg. 16-21.
Three-dimensional HIRES graphics program.
Hartley, Chuck, "Magic Cave," pg. 18-21.
An Adventure type program to locate the legendary cave with a fortune in solid gold.
Swenson, Carl, "Right/Left," pg. 50-51.
A training program for small children to teach them the differences between "left" and "right".
Blackwood, Brian and George, "Intimate Instructions in Integer Basic," pg. 53-55.
Continuing with Lesson II of this instructional series.
- 750. FROM THE CORE (May, 1980)**
Schmoyer, Jeff, "Now What's Wrong?," pg. 5-10.
A serial interface article with hardware notes and driver listing. Provides RS-232 EIA interface for the Apple to a Base 2 Model 800ST printer or a TI 810.
Budge, Joe, "High Speed Disk Initialization," pg. 10-13.
With the instructions in this article you can initialize Apple disks in 45 seconds instead of waiting 2 minutes.
- 751. Abacus II 2, Issue 4 (April, 1980)**
Waxer, Daniel A., "Memory Display," pg. 7-9.
Program, in Integer Basic, for displaying Apple memory, byte by byte.
Anon., "Applesoft Hires Routines," pg. 15.
Entry points to the machine level Hires graphics.
Anon., "HIRES Screen Function Demo," pg. 16.
Graphics demo for the Apple.
- 752. The Seed 2, No. 3 (March, 1980)**
Knaster, Scott, "Using the 'Old Monitor ROM' with the Language System," pg. 2.
Hints for using the old ROM, together with a software fix.
Foens, Bob, "Geejo," pg. 4.
Tips on easier editing, writing programs with delay loops, paddle-read program, TV interference, etc. on the Apple.
- 753. The Seed 2, No. 4 (April, 1980)**
Foens, Bob, "Geejo," pg. 5.
How to put inverse into catalog listings, mystery program, debugging tips, for the Apple.
Mills, Craig A., "Volume Number," pg. 15.
How to change the volume number on your disk, for the Apple.

754. Apple Gram 1, No. 2 (Feb., 1979)

- Carpenter, Chuck, "A Simple Disk File Program," pg. 3.
Listing and explanation of the program, for the Apple.
Matzinger, Bob, "On Printing Data in Columns," pg. 6.
Program to print information in two columns on the Apple.

755. Apple Gram 1, No. 3 (March, 1979)

- Graham, Johnny, "User Key In Routine," pg. 4.
Load and Run cassettes with one key-stroke.

756. Apple Gram 1, No. 4 (April, 1979)

- Ferrell, Bobbie, "Bugs and Butterflies," pg. 2.
Two graphics programs in Apple Hires.
Carpenter, Chuck, "Apple II Clock," pg. 7-8.
A machine language program for the Apple.
Sander-Cederlof, Bob, "Color Digits with Time of Day,"
pg. 10-11.
A clock program with graphics, Apple Lo-Res.
Santovec, Mike, "Disk JOIN Function for S-C Assembler
II," pg. 13-15.
A program providing append or join functions for disk
files, for the Apple.

757. Apple Gram 1, No. 5 (May, 1979)

- Graham, Johnny, "Machine Code Poke Generator,"
pg. 3.
How to put machine language routines into your
Applesoft or Integer Basic programs.
Sander-Cederlof, Bob, "Rounding in Applesoft," pg. 5.
Rounding off decimals on the Apple.
David, Jill, "Out of Sorts?; Part I," pg. 7-9.
A tutorial article on SORTS.

758. Apple-Com-Post 6, (Jan., 1980)

- Schultz, H.J., "H64 Ham-Interface A650 Deluxe RTTY,"
pg. 4.
An interface for the Apple II permitting RTTY in ASCII
or BAUDOT.

759. Applesauce 2, No. 1 (Jan., 1980)

- Hyde, Randy, "The Assembly Line," pg. 14-16.
Using RWTS, an Example—Fake Catalog.
Hyde, Randy, "The Apple Monitor: Video Display
Variables," pg. 25-26.
The third part of a continuing series describes zero page
locations used by the Apple Monitor.
Wayne, Phil, "APscaLLE: A 'Super' PASCAL," pg. 29-30.
A special language for the Apple based on PASCAL.

760. Apple Gram 1, No. 6 (June, 1979)

- Sander-Cederlof, Bob, "Copying Binary Disk Files,"
pg. 3.
How to find the starting address and length of binary
files on 16K, 32K, and 48K Apples.
Carpenter, Chuck, "Apple-80 Simulator," pg. 4-5.
A program to simulate the 8080 microprocessor on the
Apple.
David, Jill P., "Out of Sorts: Part II," pg. 10-14.
The second article in a series on SORTS.

761. Apple Gram 1, No. 7 (July, 1979)

- Carpenter, Chuck, "Apple II's Three M's: Part I,"
pg. 5-6.

Memory, Monitor and Machine Language are explained
in a tutorial series.

- Matzinger, Bob, "Formatting in Applesoft," pg. 14.
Lining up the decimal points in Applesoft programs.
David, Jill, "Out of Sorts: Part III," pg. 15-19.
This third article describes QUICKSORT for the Apple.

762. Sym-Physis No. 1 (Jan./Feb., 1980)

- Anon., "Relocate for the SYM-1," pg. 7-12.
Discussion and listing of a relocate program.
Gettys, Thomas, "Merge/Delete Program for SYM
Basic," pg. 8.
Machine language program for the SYM-1.
Du Peu, Maurie, "A Program to Display SYM-1 LED Seg-
ment Codes," pg. 18.
A machine language program for the SYM-1.
Wells, George, "Suggested Hardware Modification,"
pg. 18.
Add more PROMS to your SYM-1 board.

763. Apple Gram 1, No. 8 (Aug., 1979)

- Sander-Cederlof, Bob, "Euclid's Algorithm," pg. 4.
Short explanation and demo listing illustrating
'algorithm'
Laumer, Mike, "How to Get That Weird and Crazy Pro-
gram Saved to Run from Disk," pg. 6-8.
How to save 'difficult' tape programs to disk on the
Apple.
Carpenter, Chuck, "Apple II's Three M's: Part II,"
pg. 10-12.
This month's installment discusses the Apple Monitor.

764. Apple-Com-Post No. 7 (Feb., 1980)

- Goetzke, Uwe, "Pascal-eine Ein-furung," pg. 16-18.
Pascal Discussion and program for Apple.
Barbieri, Nino, "Program Kniepe," pg. 20.
Short demo graphics program in Apple Hi-Res.

765. Apple Gram 1, No. 9 (Sept., 1979)

- Carpenter, Chuck, "Apple II's Three M's: Part III,"
pg. 4-7.
The third M, Machine Language, is discussed in this
tutorial on the Apple.
Broderick, John, "Strings in Integer Basic," pg. 15.
A short tutorial on strings for the Apple Integer Basic.

766. Apple Gram 1, No. 10 (Oct., 1979)

- Marsh, Bob, "Simple Apple Serial Interface," pg. 9-11.
Hardware diagram and software listing to interface the
Heathkit H-14 printer to the Apple II.

767. Apple Gram 1, No. 11 (Nov., 1979)

- McClelland, George, "Simple Pascal Text Formatter,"
pg. 7-8.
Create a text file in the editor, then print it out on the
printer with upper and lower case using this Apple
Pascal program.
Sander-Cederlof, Bob, "Apple DOS Version 3.2.1,"
pg. 11.
Some comments on the new version of Apple DOS.
Carpenter, Chuck, "Apple II's Three M's: Part IV,"
pg. 12-14.
This time the author of this series discusses another
Apple feature, the Mini-Assembler.

768. Apple Gram 1, No. 12 (Dec., 1979)

Sander-Cederlof, Bob, "Tiny Program Displays Text Files," pg. 2.

Program makes it easy to read those Apple Text Files.

Matzinger, Bob, "SSM AIO Card," pg. 8.

Details on how to use the new AIO card from Solid State Music (SSM) to interface the Apple with the Heathkit H-14 Printer.

769. Apple Gram 2, No. 1 (Jan., 1980)

Walston, Joe, "Calendar Generator," pg. 4-5.

An Apple program for day of week, calendar, etc.

David, Jill, "Programmer's Tools," pg. 7-9.

A tutorial on the push-down stack together with a demonstration listing.

Matzinger, Bob, "Fancy Listings," pg. 10-13.

How to list your Apple Basic programs on a full width of paper and print a complete word without splitting it.

770. Apple Gram 2, No. 2 (Feb., 1980)

Broderick, John, "Please Pass the Pascal," pg. 11.

Notes on getting started in Pascal.

Zant, Robert F., "ON ERR -- Punt?," pg. 12.

Routine for intercepting error conditions using the Apple monitor.

Sander-Cederlof, Bob, "Saying HELLO with Style," pg. 14-15.

A snazzy "Hello" program for the Apple Disk.

771. Sym-Physis, No. 2 (Mar./Apr., 1980)

Brown, J.W., "Ultra Renumber for BAS-1," pg. 4-8.

An automatic renumbering program for the SYM-1.

Rinard, Phillip M., "Doodling with the KTM-2," pg. 9-15.

The KTM-2 keyboard Terminal module provides a convenient way to add a video interface to a SYM-1 as well as a keyboard.

Bach, Stephen E., "Clock Program for SYM-1 with Terminal," pg. 17-19.

A clock program converted to RAE format for the SYM-1.

Luxenberg, H.R., "24-Clock for SYM-1," pg. 20-22.

A simplified version of the previous clock version.

772. Apple Gram 2, No. 3 (March, 1980)

Sander-Cederlof, Bob, "Fancy Hello Program for Applesoft," pg. 4.

A still fancier "Hello" program for the Apple.

Firth, Mike, "More Tokens and Errors," pg. 5.

Here is a program to get you started examining BASIC programs to find memory locations that are giving you errors.

Bowser, Bob, "PRINTIT, a Pascal Program for Lower Case Output," pg. 11-14.

Take advantage of the Apple keyboard and the Pascal editor to do limited text processing with this listing.

Sander-Cederlof, Bob, "Applesoft precision," pg. 16-17.

What goes on in Applesoft and what to do if you need greater precision, up to 21 digits.

Firth, Mike, "Banner Routine," pg. 17.

A subroutine which permits you to display a lot of data on a single line of the screen.

773. Apple-Com-Post, No. 8 (April, 1980)

Schultz, Heinz Juergen, "Microphone Amplifier for the Apple II Cassette Input," pg. 9.

Two transistor amplifier makes possible use of a dynamic microphone.

Anon., "Software Tips," pg. 10-13.

A fix for a DOS error; saving High-Resolution pictures to cassette; packing Applesoft programs.

774. Apple Gram 2, No. 4 (April, 1980)

Firth, Mike, "Finding Tokens in Your Programs," pg. 6.

Examine your own programs in memory.

Hatcher, Rich, "A Joystick and an Extra Switch Input," pg. 10-13.

Hardware addition to the game output port on the Apple.

Sander-Cederlof, Bob, "Calculation of PI," pg. 15-16.

Several programs, fast and slow, for calculating PI.

775. Applesass 2, No. 4 (May, 1980)

Fred, Dennis, "Hidden Character," pg. 4.

This short program will display all control characters as inverse flashing in your Apple Catalog.

Anon., "Intermediate Applesoft," pg. 5.

Handling error messages on the Apple.

Edelstein, Arnold, "USR Function Demo," pg. 6.

Assembly language program for the Apple.

Anon., "Advanced Applesoft," pg. 7.

Apple commands USR, Call and Ampersand (&).

Buchler, Dan, "Justification Routine," pg. 9.

This routine will right justify all output to the screen.

Edelstein, Arnold, "Floating Point Tutorial," pg. 10.

This program takes decimal data entered at the Apple keyboard and returns its floating point equivalent as well as the binary equivalent of the first two bytes of the mantissa.

Edelstein, Arnold, "Wait a Bit," pg. 11-12.

Explanation of how floating point numbers are configured.

776. Robert Purser's Magazine (Spring, 1980)

Purser, Robert, "Purser's Magazine."

This magazine is the successor to "Computer Cassettes Review." It covers software for the Apple, Pet and Atari as well as Level II TRS-80. Disk programs are now included. Detailed discussions of programs are given.

777. Peek(65) 1, No. 4 (May, 1980)

Bonser, R.E., "Graphics Routine," pg. 7.

Routine for OSI computers useful in game programs.

Peabody, Al, "Framing Errors," pg. 10.

How to avoid Error 17---Framing Error, on your OS 65 U.

Lucas, J.E., "String Handling Problem," pg. 11.

String Handling problem in Microsoft BASIC for OSI computers.

Sanders, Jim, "The Exterminator," pg. 13.

A bug-correction program for the OS-65U Disk.

Sanders, Jim, "The 8K BASIC 'Wait' Instruction," pg. 14.

Discussion of the WAIT instruction and an example listing for OSI computers.

778. The Cider Press (May, 1980)

- Thompson, C.J., "The Executive Branch," pg. 6-7.
A tutorial on this useful function with 3 examples.
- Fields, Randy, "Screen Disk Commands," pg. 8.
Hints on using the Apple disk program.
- Post, Steve, "Edit + Corrections," pg. 8-9.
Fixes for problems for the EDIT+ program, for the Apple.
- Sokal, Dan, "Pascal-PEEKs and POKEs," pg. 10.
Program designed to be added to the Pascal System Library. Includes sample subroutine for keypress.
- Tyro, A., "Linelimit," pg. 11.
A Pascal program for the Apple producing a screen pause when 20 lines of text appear on the screen.

779. The Grape Vine (May, 1980)

- Lawson, Stephen M., "Sort Routines," pg. 2-3.
A Foote sort routine stripped of the custom features so it can have general use. Also given is a Singleton sort. A demo program for illustrating each is given.
- Lawson, Stephen M., "Lores POKE Demo," pg. 4.
Illustrates another method of getting colors to the Lo-Res screen on the Apple.
- Lawson, Stephen M., "Easter Calendar," pg. 5-7.
Updated calendar program including modifications for Ascension Day, Pentecost Sunday, etc.

780. Abacus II 2, Issue 5 (May, 1980)

- Robbins, Greg, "Telephone Dialer," pg. 6-7.
A dialer system that does not require a modem, only the listed software and a simple relay for the phone line.
- Freeman, Larry L. and Davis, James P., "Applesoft Menu," pg. 8.
Automatic menu for running Catalog programs on the Apple Disk.
- Robbins, Greg, "Hires Eraser," pg. 9.
Use this erase routine at the end of a program using the Apple Hi-Res screen.
- Apple Staff, "Apple Fix in DOS 3.2 & 3.2.1," pg.9.
The fix involves writing a missing 'end of file' marker.
- IAC Staff, "Application Note: List of Known Pascal Problems," pg. 11-14.
IAC will release Application Notes from time to time. Updates and Fixes for this list of Pascal problems will be released later.
- IAC Staff, "Application Note: Literal Input," pg. 15-16.
A routine for Applesoft which allows you to enter commas, quotes and colons without getting an 'extra ignored' error.
- IAC Staff, "Application Note: Stalking the Wild Left Bracket," pg. 17-18.
Apple keyboard changes to permit typing left bracket, reverse slant and underline.
- Robbins, Greg, "Modifying Your Apple to Accept User Firmware," pg. 19.
Hardware Mod to the Apple board so that it will accept your own EPROMS.
- Davis, James P., "Lister Writer," pg. 20.
Basic and machine language programs to enable listing on a Trencom 200 printer.

781. Stems From Apple 3, Issue 5 (May, 1980)

- Hertzfeld, Andy, "Andy's Switch," pg. 5-6.
Two programs that allow you to have two completely different Catalogs in a single Apple diskette.

Capella, Mark, "Hide," pg. 7.

This program for the Apple hides program names from appearing on the disk catalog.

Noble, Geoffrey E., "Hi-Res Screen Dump," pg. 12-13.

This is an updated version of the Integral Data Hi-Res Screen Dump for the IDS 440 Printer.

Stein, Dick, "File Cabinet Changes," pg. 16.

Some corrections to the previously updated version published in the January issue of Stems From Apple.

782. Apple Gram 2, Issue 5 (May, 1980)

- Broderick, John, "Pull From the Stack to Get Back," pg. 8.
Program for the Apple to show how the stack saves the return address for JSR to a subroutine.
- Matzinger, Bob, "Auto Dial," pg. 10-12.
A modified program in which data statements for new listings are added automatically to the program.
- Sander-Cederlof, Bob, "Some Corrections to the Orchard," pg. 13.
Corrections for the important article "Applesoft Internal Entry Points" published in the initial issue of the IAC Apple Orchard.
- Hatcher, Rich, "What? Another Stop-List Program?," pg. 14-15.
This one uses CTRL-S on the Apple to change speeds.

783. Apple Cookbook 1, No. 3 (May/ June, 1980)

- Jones, Tad, "Tony's Read Program," pg. 8-9.
A utility program for disk catalogs, etc.

784. Call-Apple 3, No. 4 (May, 1980)

- Hertzfeld, Andy, "Andy's Switch," pg. 7-17.
Put two different catalogs on a single disk side.
- Lingwood, Dave, "The Return of the Mysterious Mr. Ampersand," pg. 26.
You can use the Ampersand in many interesting ways.
- Gilder, Jules H., "Printer Fix for Parallel Interface with a Centronics Printer," pg. 36.
This fix is for a problem in which the Centronics Printer ignores a carriage return at the beginning of a line on the Apple.
- Kipperman, Steven M. et. al., "File Cabinet Update," pg. 41-43.
Several comments, modified listings, etc. for File Cabinet.
- Capes, Nelson R., "File Cabinet," pg. 44.
Adding input data to this oft modified and extended program.
- Huelsdonk, Bob, "Making Basic Behave: Part II," pg. 48-49.
A utility for programmers, Part II.
- Adams, Steve, "Single Drive Copy," pg. 51-52.
Copy your Apple disks with only one disk drive using this useful utility.
- Wagner, Roger, "Booting Binary Programs," pg. 53.
How to use a binary program as the 'Hello' Program in booting a diskette on the Apple.

785. Apple-Com-Post, No. 9 (May, 1980)

- Knuelle, Alfred "Hardware Tips: Paddles, Joysticks, Etc.," pg. 8.
All about accessories for the Game Port output on the Apple.

786. Sym-Physis, Issue 3 (May/June, 1980)

Sinnet, Jay C., "Hardware Modification for Better Tape Reliability," pg. 4.

A hardware modification for the SYM-1 board to improve cassette input reliability.

Luxenberg, H.R., "Cassette Recorder Tips," pg. 3.

Miscellaneous tips on increasing reliability of the SYM-1 cassette subsystem.

Cyr, Jean M., "A Sorting Patch for RAE," pg. 5-6.

A portion of "User Patch for RAE-1" which permits the printing of an alphabetically sorted Label File.

Anon., "Graphics Demonstration Package," pg. 7-9.

A graphics program in Basic, for the SYM-1.

Gowans, Bill, "Hi-Density Plotting with the KTM-2," pg. 11-18.

This routine effectively quadruples the KTM-2 graphics density by mapping a virtual 48x160 screen onto the real 24x80 screen.

Luxenberg, H.R., "Scope Graphics and Computer 'Generated' Music," pg. 12-21.

A couple of novelty demo programs and some music utility programs. Also some discussion of using Hal Chamberlin's approach to music generation on the SYM-1.

Thompson, Bruce, "Basic and the 2K Symbolic Assembler," pg. 23.

A short program called by BASIC's USR to dump or load specific memory locations.

Anon., "Inexpensive D/A Converter," pg. 24.

Hardware project based on a 4050 chip.

787. The Target (May/June, 1980)

Bresson, Steve, "Renumber," pg. 2-3.

A basic program for the AIM 65 to renumber BASIC programs.

Lowery, Dale, "Subroutines," pg. 4.

Some assembly routines used to get individual or specific characters in the AIM 65 display.

Roberts, Steve, "RS-232," pg. 6.

An interface for running a DECwriter at 300 baud with an AIM.

788. Peelings II 1, No. 1 (May/June, 1980)

Staff, "Peelings II, pg. 2.

Peelings II is a new magazine devoted to the evaluation of Apple II software. The first issue reviews in some detail eight game programs, seven technical programs and several major utilities, etc.

789. Apple Shoppe 1, No. 6 (May/June, 1980)

Anon., "Circuit Theory," pg. 7-8.

An electrical program in Pascal for the Apple.

Anon., "Graphics in Assembly, Part II," pg. 8.

A tutorial on Graphics machine language.

Anon., "Assembly, Part II," pg. 9-16.

A tutorial leading into a development example of a Text Editor.

Crouch, Bill, "Down to Business," pg. 18-20.

Handling of Disk Files with a demo routine.

Amromin, Joel L., "Pascal Linefeed Mod for AIO, etc.," pg. 23-24.

A mod for the Solid State Music AIO peripheral card for the Apple.

Russell, P. Tim, "Pascal Workshop," pg. 24-25.

Rounding Numbers in Pascal.

790. Nibble, No. 3 (May/June, 1980)

Harvey, Mike, "Text Processing with TOUGH," pg. 7.

Text outputter, updater, and generalized handler for word processing on the Apple II.

Harvey, Mike, "Apple II 'Paper Tiger' Graphics," pg. 15-17.

Subroutines to take the page 1 graphics of the Apple and convert it for printing on the Paper Tiger.

Mottola, R.M., "Machine Language Screen Dump," pg. 19.

This screen dump routine will allow you to print all or part of the Apple screen.

Floeter, Alan D., "Applesoft REM Remover- Or, Now You See It, Now You Don't," pg. 20.

Decrease the memory space required and the execution speed by removing those REM statements from your Applesoft listing.

Connolly, Rick, "Improving the Multiple Array Sort," pg. 26-27.

How to realize the speed advantage in sorts such as the Shell-Metzner sort.

791. Rubber Apple User Group Newsletter 3, No. 6

Gabelman, Ken, "Disk Structures II," pg. 4.

Tutorial on random files as applied to a mailing list.

792. The Harvest 1, No. E (July, 1980)

Allen, Earl, "Applesoft Fast File Accessing," pg. 1-3.

A fast method of handling massive amounts of data is described for the Apple disk system.

Stadfeld, Paul, "Turtleshapes," pg. 7-8.

A novel graphics program in Apple Hi-Res using some of the principles of Pascal Turtlegraphics.

793. The River City Apple Corps Newsletter (June, 1980)

Wyman, Curt, "Hi-Res Graphics: Rotating Three Dimensional Shapes," pg. 2-4.

A graphics tutorial.

Sethre, Tom, "Roots," pg. 4-6.

A tutorial on machine language loops using the 6502.

794. The Seed 2, No. 6 (June, 1980)

Rahn, Ray, "Ray's Apple Crib Sheet," pg. 10-13.

Basics in the operation of the Apple Disk system.

795. Cider Press (June, 1980)

Anon., "Apple Tricks," pg. 6.

A patch to DOS 3.2 of the Apple disk system which will make it INIT a disk in half the time and boot up in 2 seconds.

796. Abacus II 2, Issue 6 (June, 1980)

Wine, Hal, "Apple II ROM Monitor Subroutine List," pg. 4-8.

Discussion of a variety of monitor subroutines.

Freeman, Larry, "The Hole in Apple's Integer Numbers," pg. 8-10.

A bug, a fix and an instructive explanation of it all.

Wine, Hal, "Color Generation in Hi-Res," pg. 12-14.

An explanation of how the Apple Hi-Res colors are generated.

SBCS



GENERAL LEDGER offers you

- ★ *Virtually complete flexibility in formatting balance sheets and income statements.*
- 31-character account names.
- 6 digit numbers.
- 10 levels of subtotals for more detailed income statements and balance sheets.
- up to 9 departments.
- ★ A cash journal that automatically calculates the proper off-setting entry and allows a 33-character transaction description.
- ★ A balance sheet and income statement for the current month, quarter, or any of the previous three quarters.

We are the authorized center for Osborne/McGraw-Hill providing you with business packages that will do everything the Osborne Software will do in addition to many features we have added.

BE SURE TO READ THE MICROSCOPE REVIEW IN THE NOVEMBER ISSUE!

ACCOUNTS RECEIVABLE allows you to:

- Enter invoices at any time.
- Keep track of invoice amounts, shipping charges, and sales tax (automatically computed).
- Accumulate total payments including progress billing information on each invoice.
- Print reports which list unbilled invoices, unpaid invoices, and paid invoices.
- Obtain an aging analysis of unpaid invoices.
- Assign your own alphanumeric customer code.
- Maintain the date of the last activity for each customer, as well as amounts billed this year and last year.
- Print Customer Statements. (Statements available through SBCS).

★ **Accounts Receivable** is available independently or can be integrated with the General Ledger program.

In the final analysis, making your bookkeeping easier is what our software is all about. There is virtually no limit on entries since you may process them as often as you like. These packages will support any printer/interface combination.

General Ledger requires one hundred ten columns.

Accounts Receivable requires one hundred thirty columns.

Suggested Retail:

Individually	\$180.00
Together	\$330.00
McGraw-Hill manuals (required for documentation)	\$20.00 ea.

Available from your local Apple Dealer or contact SBCS.

YOU NEED EXPERIENCE WORKING FOR YOU!

Contact or write:

SMALL BUSINESS COMPUTER SYSTEMS
4140 Greenwood — Lincoln, Nebraska 68504 — (402) 467-1878

Letterbox

(continued from page 59)

Dear Editor:

I am an AIM 65 user and I have written a few assembly language programs that may be of interest to others. I would like to sell these programs, but I don't know much about this.

Would it be better to just write an ad or write an article, say for MICRO, describing these programs with an offer to sell software on cassette, or what? How does one establish a market value? Should just the object code or both source and object be released?

Alan M. Davis
RFD #2130, Rt. 106
Syosset, New York 11791

You will find a detailed discussion of software distribution on the editorial page of our October and November issues (29:5 and 30:5).

If an article on software is to be considered for publication in MICRO, the article must include the software print-out, not merely a description of it. In this case, the author offers his software to the public without charging for it.

If an author wishes to sell software, through the medium of MICRO, he has three ways of doing so. He can queue up for a free listing in The MICRO Software Catalog, which appears in each issue; he can submit a classified ad; or he can place a display ad. We have a backlog of listings for The MICRO Software Catalog, so an author will have to wait his turn. (His listing must also follow our strict format.) A classified ad will be published immediately, but is limited in size and attracts a minimum amount of attention. Display ads cost more, but offer the greatest freedom to advertisers—a variety of possible sizes, flexibility in content, design, typography, and placement within the publication. They can also be scheduled to coincide with the dates when software is ready for release. In addition, reduced rates are available for those who advertise frequently.

On the subject of usefulness—both the source and object codes are more useful to purchasers than just the object code.

The Editor

MICRO

MICRO wants to obtain more

**Foreign and Domestic
Dealers and Distributors**

To learn why you should carry MICRO products,
(MICRO - the 6502 Journal, The BEST OF MICRO
Series, and additional special interest publications)
write or call:

**James Anderson
Marketing Director**

MICRO wants to tell advertisers more
about why they should advertise
in forthcoming issues.
For details, please write or call:

**Cathi Bland
Advertising Manager**

MICRO
P.O. Box 6502
Chelmsford, MA 01824
(617) 256-5515

**Statement of Ownership,
Management
and Circulation**

Required by the act of Congress of October 23, 1962, of
MICRO, published monthly at Chelmsford, Massachusetts for
September 1980:

The name and address of the publisher is **MICRO INK, Inc.**, 34
Chelmsford Street, Chelmsford, Massachusetts. The Editor/
Publisher is Robert M. Tripp of Chelmsford, Massachusetts.

The owner is **MICRO INK, Inc.**, Chelmsford, Massachusetts,
and the names and addresses of stockholders owning or holding
one percent or more of the total amount of stock are: Robert M.
Tripp and Donna M. Tripp of Chelmsford, Massachusetts.

The known bondholders, mortgagees and other security
holders owning one percent or more of the total amount of
bonds, mortgages or other securities are: none.

The average number of copies of each issue of this publication
sold or distributed through the mails or otherwise to paid
subscribers during the twelve months preceding the date shown
above is: 10,521.

I certify that the statements made by me above are correct and
complete.

Signed: Robert M. Tripp
Editor/Publisher

ADVERTISERS' INDEX

December 1980

Advertiser's Name	Page
Aardvark Technical Services	60
Abacus Software	34
American Data, Inc.	63
Andromeda Incorporated	41
Avante-Garde Creations	6
Bap\$ Software	86
Beta Computer Devices	20
E.H. Carlson	13
CJM Industries	31
Classifieds	35
Commodore Business Machines	IBC
The Computerist, Inc.	56, 64
Computer Shop	81
Computers-R-Us	77
Creative Computing	78
Cyber Associates	13
Dakin 5 Corp.	74
Decision Systems	35
Dr. Dobbs Journal	50
Dwo Quong Fok Lok Sow	86
Eastern House Software	34, 96
E & I Technical Services	81
Excert, Inc.	70
F.S.S.	34
Galaxy	10
Hepburn, MCA	20
Highland Computer Services	30, 88
Hudson Digital Electronics	24
Instant Software, Inc.	54, 55
Lazer Systems	4
Malibu Microcomputing	2
Micro	42
MicroMotion	6
MicroWare Dist.	31
Mittendorf Engineering	63
Money Disk	10
Nestar Systems, Inc.	44
Nibble	32
Nikrom Technical Products	36
Ohio Scientific	BC
OS Small Systems Journal	82-85
On-Line Systems	24, 74, 86, 88
Orion Software Associates	86
Pegasus Software	88
Perry Peripherals	23
Programma International	IFC
Progressive Computer Software	47
Progressive Computing	81
Progressive Software	35
Rainbow Computing	47
Sirius Software	14
Skyles Electric Works	14, 48, 49
Small Business Computer Service	94
Software Technology for Computers	6
Southeastern Software	1
Stoneware Microcomputer Products	10
Versa Computing, Inc.	52
Voicetek	14

SPECIAL - 10% OFF

ON THE PURCHASE OF ALL HARDWARE
PURCHASED THIS MONTH ONLY

INTRODUCING ROM PET RABBIT OR CASSETTE

The PET RABBIT contains high-speed cassette routines, auto-repeat key feature, memory test, decimal to hex, hex to decimal, and other features. Coexists with the BASIC PROGRAMMERS TOOLKIT. Works with 2.0 ROMS (New) and new style cassette deck.

Cassette versions configured for \$1800, \$3000, \$3800, \$7000, and \$7800.

Cassette and manual — \$29.95

ROM version configured to plug into P.C. board at \$A000.

ROM and manual — \$49.95

FREE ROM RABBIT with purchase of 8K PET and tape deck.

SPECIAL — ROM RABBIT and cassette deck — only \$134.95

MACRO ASSEMBLER AND TEXT EDITOR

Macro and conditional assembly, string search and replace, 10 char./label, AUTO line numbering, MOVE, COPY, DELETE, NUMBER, and much more. 20+ commands, and 20+ pseudo ops.

PET cassette version (ASSM/TED) — \$49.95

PET disk version (MAE) — \$169.95

ATARI cassette version with machine language monitor — \$53.95

FREE ASSM/TED and ROM RABBIT with purchase of 32K PET and cassette deck.

FREE MAE with purchase of 32K PET and disk drive.

TINY-C FOR PET

An adaptation of the TINY-C interpreter sold by Tiny-C Assoc. Useful for learning a modern structured programming language Diskette — \$45.00, Owners manual — \$40.00

FREE MAE and TINY-C with purchase of 32K PET, disk drive, and printer.

COMPILERS

Graphics Drawing Compiler for PET and SYM. Works with Macro ASSM/TED. The GDC is composed of a number of macros which emulate a high-level graphics drawing language. In addition to the macros, GDC provides some very useful enhancements to the ASSM/TED. Manual and Cassette — \$29.95

Music and Sound Composer for PET. Works with Macro ASSM/TED. The MSC is composed of a number of macros which emulate a high-level computer music language. In addition to the macros, MSC provides some very useful enhancements to the ASSM/TED. Manual and Cassette — \$29.95

I/O KIT

PET I/O Experimenters Kit. Allows easy access to IEEE or user port for the construction of external circuits. Kit — \$39.95

ORDERING TERMS

Send check or money order in U.S. dollars. Add 2% for postage for CBM orders. Overseas software orders add \$5.00. All software mailed free in USA and Canada. Purchase orders acceptable.

EHS IS NOW A COMMODORE DEALER

EHS offers a number of software products for PET, ATARI, APPLE, and other 6502 computers. Now we sell CBM hardware. If you're in the market for PET products, be sure to look for our FREE software offers.

CBM	PRODUCT DESCRIPTION	PRICE
2001-8KN	8K RAM-Graphics Keyboard	\$ 795.00
2001-32KN	32K RAM-Graphics Keyboard	\$1295.00
2001-32KB	32K RAM-Business Keyboard	\$1295.00
8032	32K RAM-30 Col.-4.0 O/S	\$1795.00
2023	Friction Feed Printer	\$ 695.00
2022	Tractor Feed Printer	\$ 795.00
2040	Dual Floppy-343K-DOS 1.0	\$1295.00
2050	Dual Floppy-343K-DOS 2.0	\$1295.00
8050	Dual Floppy-974K-DOS 2.0	\$1695.00
C2N Cassette	External Cassette Drive	\$ 95.00
CBM to IEEE	CBM to 1st IEEE Peripheral	\$ 39.95
IEEE to IEEE	CBM to 2nd IEEE Peripheral	\$ 49.95
8010	IEEE 300 Baud Modem	\$ 395.00
2.0 DOS	DOS Upgrade for 2040	\$ 50.00
4.0 O/S	O/S Upgrade for 40 Column	\$ 100.00

EDUCATIONAL DISCOUNTS BUY 2 — GET 1 FREE

TRAP 65

TRAP 65 prevents the 6502 from executing unimplemented instructions. Have you ever had your system to crash on a bad opcode? This is a real machine language debugging tool and time saver. Also useful for teaching trap vectoring and extension of instruction set in schools. 3½ x 4¾ printed circuit board which plugs into 6502 socket of any PET, APPLE, SYM. Only \$149.95

ATARI M.L. MONITOR

Load and save binary data on cassette. Display and change 6502 registers. Will coexist with BASIC. Monitor uses the screen editing capabilities of the ATARI to allow easy use. Cassette and manual — \$9.95 (specify memory size).

ATARI MEMORY TEST

When you purchase a new ATARI or add on new RAM modules, you need to be sure that the memory is working properly. (Remember, you only have a short guarantee on your memory!) Cassette and manual — \$4.95

APPLE PRODUCTS

Macro ASSM/TED — includes manual, on cassette — \$49.95, on disk — \$55.95

Apple MAE — similar to PET MAE. A powerful assembly development system on diskette. (Requires license agreement) — \$169.95

PIG PEN — 100% M.L. word processor for use with Apple ASSM/TED. Fast text formatting, vertical and horizontal margins, right and left justification, centering, titles, foots, shapes, etc. Manual and source included. on cassette — \$40.00, on diskette — \$45.00

Apple Mail List System. Provides sorting on zip code or last name. Approximately 1000 names/diskette. Manual and Diskette — \$34.95

EASTERN HOUSE SOFTWARE

3239 Linda Drive, Winston-Salem, N.C. 27106

Ph. Orders — 9-4 EST (919) 924-2889 or 748-8446

Send SASE for free catalog

The Great American Solution Machine.

More than 50,000 students, teachers and administrators solve problems with this reliable Commodore computer.

You're looking at the Number One computer in education today.

In fact, you've probably already used it.

The Commodore.

You know it teaches.

Guides. Challenges.
Analyzes. Organizes.
Simplifies.

But did you know it has capabilities that are far beyond its price range?

You can accomplish tasks with The Commodore at a price/performance ratio that leads the field.

You can also count on The Commodore showing up for class every day.

It's a remarkably sophisticated, remarkably reliable machine. Around the world in

schools—and businesses too—there are more than 100,000 Commodore computers now at work.

If you sense a snag in the flow of knowledge in your classes, we think you should challenge The Commodore.

Compare it against any computer in—or above—its field.

See if it won't raise the level of interest and accomplishment among your students.

And simplify the complex in your administrative duties.

All at a price that makes it stand alone.

For the name of your nearest authorized Commodore dealer, just write to: Commodore Business Machines, Inc., 950 Rittenhouse Rd., Norristown, PA 19401

Call now toll-free. Ask for operator 973:

800-824-7888

(In Calif., 800-852-7777)

(In Alaska and Hawaii, 800-824-7919)

commodore

COMMODORE



The home computer you thought was years away is here.



C8P DF

Ohio Scientific's top of the line personal computer, the C8P DF. This system incorporates the most advanced technology now available in standard configurations and add-on options. The C8P DF has full capabilities as a personal computer, a small business computer, a home monitoring security system and an advanced process controller.

Personal Computer Features

The C8P DF features ultra-fast program execution. The standard model is twice as fast as other personal computers such as the Apple II and PET. The computer system is available with a GT option which nearly doubles the speed again, making it comparable to high end mini-computer systems. High speed execution makes elaborate video animation possible as well as other I/O functions which until now, have not been possible. The C8P DF features Ohio Scientific's 32 x 64 character display with graphics and gaming elements for an effective resolution of 256 x 512 points and up to 16 colors. Other features for personal use include a programmable tone generator from 200 to 20KHz and an 8 bit companding digital to analog converter for music and voice output, 2-8 axis joystick interfaces, and 2-10 key pad interfaces. Hundreds of personal applications, games and educational software packages are currently available for use with the C8P DF.

Business Applications

The C8P DF utilizes full size 8" floppy disks and is compatible with Ohio Scientific's advanced small business operating system,

OS-65U and two types of information management systems, OS-MDMS and OS-DMS. The computer system comes standard with a high-speed printer interface and a modem interface. It features a full 53-key ASCII keyboard as well as 2048 character display with upper and lower case for business and word processing applications.

Home Control

The C8P DF has the most advanced home monitoring and control capabilities ever offered in a computer system. It incorporates a real time clock and a unique FOREGROUND/BACKGROUND operating system which allows the computer to function with normal BASIC programs at the same time it is monitoring external devices. The C8P DF comes standard with an AC remote control interface which allows it to control a wide range of AC appliances and lights remotely without wiring and an interface for home security systems which monitors fire, intrusion, car theft, water levels and freezer temperature, all without messy wiring. In addition, the C8P DF can accept Ohio Scientific's Votrax voice I/O board and/or Ohio Scientific's new universal telephone interface (UTI). The telephone interface connects the computer to any touch-tone or rotary dial telephone line. The computer system is able to answer calls, initiate calls and communicate via touch-tone signals, voice output or 300 baud modem signals. It can accept and decode touch-tone signals, 300 baud modem signals and record incoming voice messages.

These features collectively give the C8P DF capabilities to monitor and control home functions with almost human-like capabilities.

Process Controller

The C8P DF incorporates a real time clock, FOREGROUND/BACKGROUND operation and 16 parallel I/O lines. Additionally a universal accessory BUS connector is accessible at the back of the computer to plug in additional 48 lines of parallel I/O and/or a complete analog signal I/O board with A/D and D/A and multiplexers.

Clearly, the C8P DF beats all existing small computers in conventional specifications plus it has capabilities far beyond any other computer system on the market today.

C8P DF is an 8-slot mainframe class computer with 32K static RAM, dual 8" floppies, and several open slots for expansion.

Prices start at under \$3,000.

Computers come with keyboards and floppies where specified. Other equipment shown is optional.

For literature and the name of your local dealer, CALL 1-800-321-6850 TOLL FREE.

OHIO SCIENTIFIC
1333 SOUTH CHILLICOTHE ROAD
AURORA, OH 44202 • (216) 831-5600